

Modeling, Control and Power Management Strategy of a Grid connected Hybrid Energy System

Sujit Kumar Bhuyan¹, Prakash Kumar Hota², Bhagabat Panda³

^{1,3}School of Electrical Sciences, KIIT University, Bhubaneswar, India

²Department of Electrical Engineering, Veer Surendra Sai University of Technology, Burla, India

Article Info

Article history:

Received Jan 21, 2018

Revised Mar 10, 2018

Accepted Mar 29, 2018

Keyword:

Electrolyzer

Grid

PV model

Solid oxide fuel cell

Storage tank

ABSTRACT

This paper presents the detailed modeling of various components of a grid connected hybrid energy system (HES) consisting of a photovoltaic (PV) system, a solid oxide fuel cell (SOFC), an electrolyzer and a hydrogen storage tank with a power flow controller. Also, a valve controlled by the proposed controller decides how much amount of fuel is consumed by fuel cell according to the load demand. In this paper fuel cell is used instead of battery bank because fuel cell is free from pollution. The control and power management strategies are also developed. When the PV power is sufficient then it can fulfill the load demand as well as feeds the extra power to the electrolyzer. By using the electrolyzer, the hydrogen is generated from the water and stored in storage tank and this hydrogen act as a fuel to SOFC. If the availability of the power from the PV system cannot fulfill the load demand, then the fuel cell fulfills the required load demand. The SOFC takes required amount of hydrogen as fuel, which is controlled by the PID controller through a valve. Effectiveness of this technology is verified by the help of computer simulations in MATLAB/SIMULINK environment under various loading conditions and promising results are obtained.

Copyright © 2018 Institute of Advanced Engineering and Science.
All rights reserved.

Corresponding Author:

Sujit Kumar Bhuyan,
School of Electrical Engg Engineering,
KIIT University,
Bhubaneswar, India.
Email: sujeet.bhuyan@gmail.com

1. INTRODUCTION

Due to the considerations of environment condition, applications of renewable energy sources (RESs) are more promising; that makes environment pollution free. Also, their availability is cost free and continuous [1], [2]. Numerous RESs consist of photovoltaic system (PV), wind turbine system (WT) and micro-turbines, etc. which are considered as components of hybrid energy systems in the literature and also demonstrate applications of micro-grid [3], [4]. Due to the various seasonal and bad weather conditions such as temperature, wind speed, solar radiation and also geographical conditions, these structures are not worked properly. So, the solutions must be needed and find out. Hence, energy storage systems (ESSs) are suitable for the solution of the mitigation of wind effects, solar radiation fluctuations and also ESSs uphold the power and energy balance. Power quality also improves due to ESSs. Due to the fast variations of power, ESSs must contain a high power density as well as high energy density. So, it is required to keep more than one storage system for a hybrid energy storage system (HESS) [5]-[7]. The ESSs and battery banks (BBs) are efficiently used in hybrid energy systems (HESs). But, lifetime of batteries decreases due to the charging and discharging cycles [8], [9]. A secondary energy sources is required to enhance the supply energy reliability of HESs. Hence, a fuel cell (FC) is required to combine with the electrolyzer by giving a continuous supply to the load [10], [11]. The strategies of energy management consist of combination of PV, WT and FC comprising with electrolyzer as well as battery storage. These are most effective practice for quality of higher

energy requirement. Further, micro-grid comes into interface with the distributed generation and for the decentralized management, the grid is connected with this micro-grid [12]. Now a day's DC loads are increasing in electric vehicles, residential, commercial and industrial buildings. So, the loads in power system might be DC dominated in the subsequent time. If AC grid supplies these type of DC loads, then AC/DC as well as DC/DC converters are required in near future. These converter equipments combine with the individual DC or AC grid, so the cost is increased as well as cause the additional losses. In the meantime the overall efficiency is reduced for the particular system. Numerous studies and configurations have been suggested in [13]-[16] for the application of the hybrid energy system. A HES normally consists of individual DC grid or AC grid that can beat the fact that DC loads connect with the DC grid [17] and AC loads connect with the AC grid, also DC or AC grids are associated with the bidirectional converter [18].

From [18], a hybrid system includes PV system, WT system as well as FC. So, the hybrid system reduced the power electronics equipments such as AC/DC or DC/AC converters in the separate DC or AC grid applications. Also, FC is operated separately without batteries. But, robustness, vector control, advantages of WT-DFIG are not suggested, also their operations modes are not considered and further pitch angle control is not considered. Amongst other, Tamalouzt *et al.* [19] have discussed a direct torque and reactive power control of grid connected doubly fed induction generator for the wind energy conversion. Tazerart *et al.* [20] have described a direct torque control implementation method with losses minimization of induction motor for electric vehicle applications with high operating life of the battery. Bhende *et al.* [21] have designed a permanent magnet synchronous generator-based standalone wind energy supply system. Onar *et al.* [22] have described dynamic modeling, design and simulation of a wind/fuel cell/ultra-capacitor-based hybrid power generation system. In HES though wind integration looks attractive in terms of requirement of active power still the cost and control technique are the major drawbacks of this technology in addition to noisy environment.

The major contribution of this paper is modeling of a new configuration of grid connected HES consisting of PV, electrolyzer, storage tank and SOFC which are simulated together. Particularly, the detailed modeling of hydrogen flow from electrolyzer to SOFC through storage tank which is not available in the literature has also been provided in this paper. Advantage of this technology shows the accessibility of grid (AC and DC). Hence, hybrid system increases power management capability of the grid. This paper provides the overall description of the proposed methodology. Further, detailed modeling and control strategy of each equipment of the system is described. A supervisory control strategy and also a management strategy of the system are presented. Finally, the effectiveness of the proposed HES is confirmed through the simulation under several situations such as variation in power demand and various meteorological conditions.

2. MODELING OF COMPONENTS OF PROPOSED GRID CONNECTED HES

The proposed model is shown in Figure 1. In this model the PV system is regulated by the maximum power point tracking algorithm (MPPT) and it is also interfaced with the boost converter to boost up the DC voltage. Then this DC voltage (V_{pv_boost}) is applied to DC/AC converter to convert DC voltage to AC voltage. Solar energy depends upon the weather conditions; so when the solar radiation is weak or it is absence for sometimes, then the SOFC comes into interface because integration of the system with SOFC makes it more sustainable. Further, when power generation is more from Sun for a long period, then the electrolyzer takes part to consume the excess electric power and generate hydrogen. This hydrogen is stored in storage tank in compressed manner and further utilized as a fuel of the SOFC. Therefore, the power management strategy of this HES is developed to minimize the effect of daily as well as seasonal variations due to the conditions containing climatic and geographical. So, RES results a polished output power, also satisfy the power requirement. Operating performances of HES depend on stability of the voltage of DC bus when disturbances/faults occur or when power demand fluctuation is rapid. When, voltage fluctuations is more, then power converters show more power losses and more injection of harmonics towards the grid.

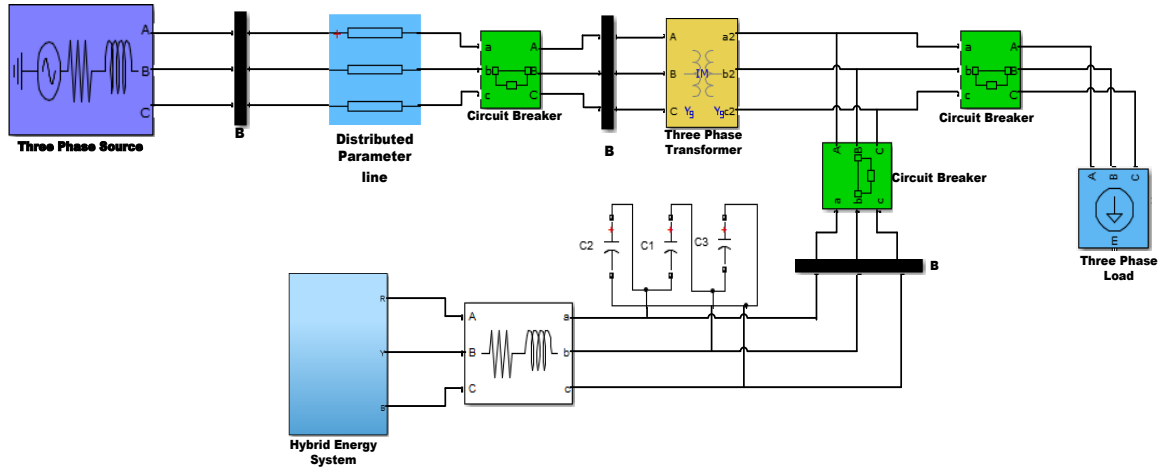

Figure 1. Hybrid system connected to grid (Proposed Model)

2.1. Modeling of photovoltaic (PV) system

Mathematical model of the PV system is shown in [15], [16]. The power characteristic of the PV system is represented in [2]. To draw out the maximum power which is available in PV array, it is useful to operate the PV system at MPPT. Maximum power point tracking (MPPT) is a process where PV array, inverters which are connected to grid and other similar devices are employed to extract the maximum amount power. Hence, the PV module is designed with the help up MATLAB/SIMULINK by considering the following Equation (1). Also Table 1 contains specifications of the photovoltaic (PV) array.

$$V_{pv} = \frac{N_s a k T}{q} \ln \left[\frac{I_{sc} - I_{pv} + N_p}{N_p I_0} \right] - \frac{N_s}{N_p} R_s I_{pv} \tag{1}$$

Parameters considered to design the PV system such as I_0 is the reverse saturation current of PV cell in [A], I_{sc} is the short-circuit PV cell current in [A], I_{pv}/I_{ph} is the output current of PV cell in [A], k is the boltzmann’s constant in [J/°K], a is the completion or ideality factor, q is the electron charge in [C], R_p is the PV cell containing parallel resistance in [Ω], R_s is the PV cell containing series resistance in [Ω], N_s is the no. of series cells in a string of the PV cell, N_p is the No. of parallel strings, T is the temperature of the PV cell in [K], V_{pv} is the PV cell terminal voltage in volt in [V], V_{MP} is the voltage related to maximum power of the PV cell in [V], V_{oc} is the PV cell open-circuit voltage in volt in [V].

Table 1 Specifications of Photovoltaic (PV) array

Specification	Value
No. of series connected PV cell	96
No. of Modules in parallel	66
No. of Modules in series	05
Open circuit voltage (V_{oc})	64.2 V
Short circuit current (I_{sc})	5.96 A
Maximum Power of PV cell	305W
Temperature (T)	25
Irradiance	1000

2.2. Modeling of electrolyzer

Electrolyzer is used to decompose the water (H_2O) into two elements, first one is hydrogen and another one is oxygen by circulating the electric current in the electrolyzer containing two separate electrodes. The process is called electrolytic process or electrolysis [11].

The electrolysis equation of water is shown below:

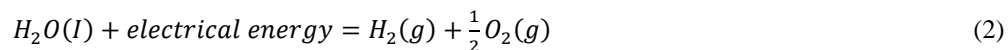

Parameters used for modeling of an electrolyzer are i_e is the current of an electrolyzer in [A], n_c is the no. of series connected electrolyzer cells, nH_2 is the amount of hydrogen generated in moles per second in $[mol\ s^{-1}]$, F is the faraday constant in $[C\ kmol^{-1}]$, η_F is the Faraday efficiency.

Electrical current is directly related to the rate of production of hydrogen of the electrolyzer as shown in Faraday's law given below [22].

$$nH_2 = \frac{n_F n_c i_e}{2F} \tag{3}$$

The ratio of the actual amount of hydrogen generated by the electrolyzer to the theoretical value is represented as Faraday efficiency.

$$\eta_F = 96.5e^{\left(\frac{0.09 - 75.5}{i_e - i_e^0}\right)} \tag{4}$$

From the Equations (3) and (4), an electrolyzer model is designed through the help of Simulink that is shown in Figure 2.

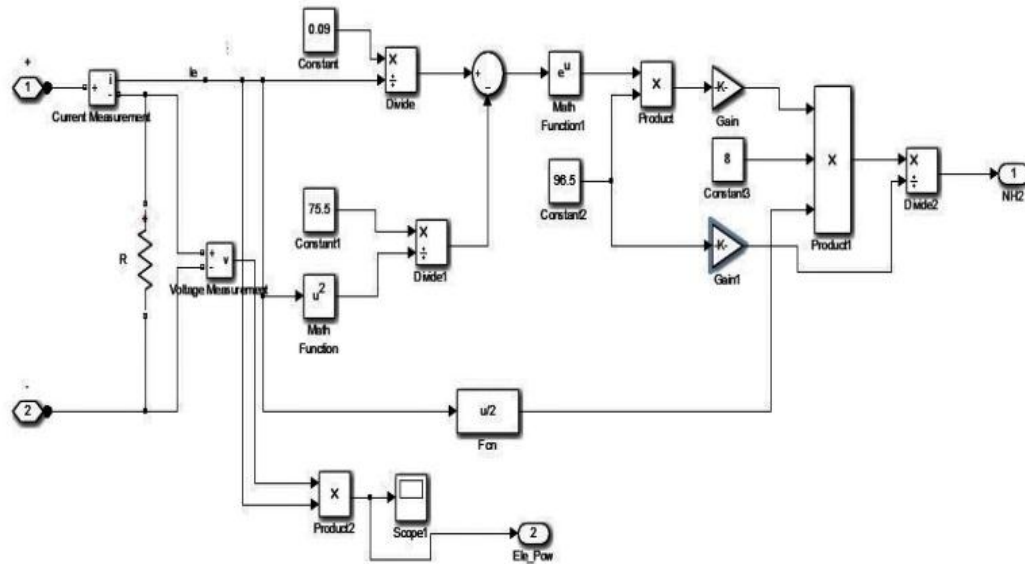

Figure 2. A brief model of electrolyzer using Simulink

2.3. Modeling of storage tank

Hydrogen is produced by the electrolyzer, then this generated hydrogen acts as fuel of the SOFC. According to the output power, SOFC consumed the required amount of hydrogen. The difference between the generated hydrogen and required amount of hydrogen is stored in the storage tank in storage tank.

In the hydrogen storage tank, the hydrogen is stored in compressed liquid or gaseous form. The hydrogen storage tank is designed according to the Equation (5) and tank pressure is directly calculated by considering the difference amount of hydrogen flow to the storage tank [22]. Figure 3 shows the brief model of hydrogen storage tank using Simulink.

$$P_b - P_{bi} = z \frac{NH_2 RT_b}{MH_2 V_b} \tag{5}$$

Parameters used for modeling of the storage tank such as Z is the pressure compressibility factor, NH_2 is the amount of hydrogen stored in the storage tank in moles per second in $[kmol\ s^{-1}]$, MH_2 is the hydrogen molar mass in $[kg\ kmol^{-1}]$, T_b is the operating temperature in $[^{\circ}K]$, P_{bi} is the storage tank pressure at initial stage, P_b in storage tank pressure, R is the rydberg/Universal gas constant in $[J\ (kmol\ ^{\circ}K)^{-1}]$, V_b is the storage tank volume in $[m^3]$.

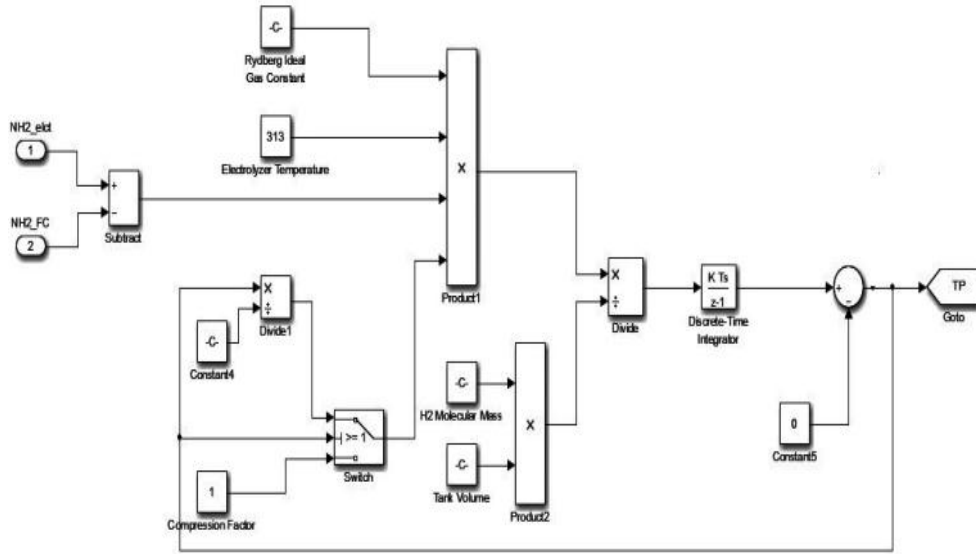

Figure 3. A brief model of hydrogen storage tank using Simulink

2.4. Modeling of solid oxide fuel cell (SOFC)

Parameters of the SOFC which are used to develop the mathematical model are given in [23], where B and C is the activation voltage constants are used to simulate in SOFC system in [V], CV is the conversion factor in $\left[\frac{\text{Hydrogen (kmoh)}}{\text{Methen (kmoh)}}\right]$, E₀ is the normal no load voltage in [V], E is the nernst immediate voltage in [V], F is the Faraday’s constant in [C (kmol⁻¹)], I_{FC} is the feedback current of SOFC in [A], k₁ is the gain of PI, Kan is the anode valve constant in $[\sqrt{\text{kmol kg}(\text{atm s})^{-1}}]$, K_r is the modeling constant in [kmol SA⁻¹], K_{H2O} is molar constant of water valve in [kmol (atm s⁻¹)], K_{H2} is the molar constant of hydrogen valve in [kmol (atm s⁻¹)], K_{O2} is the molar constant of oxygen valve in [kmol (atm s⁻¹)], M_{H2} is the hydrogen molar mass in [kg kmol⁻¹], P_{H2O} is the water fractional pressure in [atm], P_{H2} is the hydrogen fractional pressure in [atm], P_{O2} is the oxygen fractional pressure in [atm], N₀ is the no. of fuel cells are in series in a stack, q_{H2} is the molar flow of hydrogen in [kmols⁻¹], q_{methane} is the methane flow rate in [kmols⁻¹], q_{O2} is the input molar flow of oxygen in [kmols⁻¹], q_{H2}ⁱⁿ is the input flow of hydrogen in [kmols⁻¹], q_{H2}^{out} is the hydrogen output flow in [kmols⁻¹], q_{H2}^r is the hydrogen flow amount that reacts in [kmols⁻¹], q_{H2}^{req} is the hydrogen flow amount that meets load change in [kmols⁻¹], R is the Rydberg (Universal) gas constant in [(1atm) (kmol K)⁻¹], R_{int} internal resistance of SOFC in [Ω], T is the absolute temperature in [K], U is the utilization rate, V_{an} is the volume of the anode in [m³], V_{cell} is the SOFC dc output voltage in [V], τ₁, τ₂ is the reformer time constants in [s], τ₃ is the PI controller time constant in [s], τ_{H2} is the hydrogen time constant in [s], τ_{H2O} is the water time constant in [s], τ_{O2} is the oxygen time constant in [s], Z_{act} is the activation over voltage in [V], Z_{ohmic} is the ohmic over voltage in [V].

The ratio between the hydrogen molar flow through the valve and partial pressure of hydrogen in the channel can be represented as [23].

$$\frac{q_{H2}}{P_{H2}} = \frac{K_{an}}{\sqrt{M_{H2}}} = K_{H2} \tag{6}$$

Three important factors can be considered due to the flow of hydrogen: input flow and output flow of hydrogen and flow of hydrogen at the time of reaction. So, the equation can be developed by considering these factors.

$$\frac{d}{dt} p_{H2} = \frac{RT}{V_{an}} (q_{H2}^{in} - q_{H2}^{out} - q_{H2}^r) \tag{7}$$

Reacted hydrogen flow rate is determined by considering the relationship between SOFC current and hydrogen flow.

$$q_{H2}^r = \frac{N_0 I_{FC}}{2F} = 2K_r I_{FC} \tag{8}$$

The hydrogen partial pressure is determined by considering the laplace transform of the Equations (6) and (8).

$$P_{H_2} = \frac{1/K_{H_2}}{1+\tau_{H_2}s} (q_{H_2}^{in} - 2K_r I_{FC}) \quad (9)$$

where,

$$\tau_{H_2} = \frac{V_{an}}{K_{H_2}RT} \quad (10)$$

In this way oxygen partial pressure as well as water partial pressure are determined. The summation of the activation over voltage, Nernst's voltage, and the ohmic over voltage gives the result of SOFC polarization curve by considering the oxygen concentration and temperature to be constant. The voltage output of SOFC power plant can be indicated as:

$$V_{cell} = E + \eta_{act} + \eta_{ohmic} \quad (11)$$

where,

$$\eta_{act} = -B \ln(CI_{FC}) \quad (12)$$

and

$$\eta_{ohmic} = -R^{int} I_{FC} \quad (13)$$

So, Nernst instantaneous voltage can be obtained as:

$$E = N_o \left[E_o + \frac{RT}{2F} \log \left[\frac{P_{H_2} \sqrt{P_{O_2}}}{P_{H_2O}} \right] \right] \quad (14)$$

The power plant of SOFC takes the hydrogen as a fuel to fulfill the requirement of power demand but the hydrogen is continuously supplied by the reformer for the SOFC stack operation. The model of the reformer can be represented as:

$$\frac{q_{H_2}}{q_{methanol}} = \frac{CV}{\tau_1 \tau_2 s^2 + (\tau_1 + \tau_2)s + 1} \quad (15)$$

A PID controller is used to control the flow of hydrogen according to the requirement of output power of SOFC system. SOFC output current is taken as an input of the SOFC to obtain the feedback control and is given by:

$$q_{H_2}^{req} = \frac{N_o I_{FC}}{2FU} \quad (16)$$

The availability of the hydrogen of the reformer can be utilized to maintain methane flow by the help of PI controller. It can be expressed as:

$$q_{methane} = \left(k_1 + \frac{k_1}{\tau_3 s} \right) \left(\frac{N_o I_{FC}}{2FU} - q_{H_2}^{in} \right) \quad (17)$$

A 5 KW SOFC is designed by using the above parameters as shown in Table 2 and Figure 4 shows a brief model of SOFC system using simulink [24]. In this proposed model three 5 KW SOFCs are used.

Table 2. Specifications of SOFC to design the mathematical model

Specification	Value
Activation voltage constant (B)	0.04777 [A ⁻¹]
Activation voltage constant (C)	0.0136 [V]
Conversion factor (CV)	2
Faraday's constant (F)	96 484 600 [Ck ^{mol} ⁻¹]
FC system internal resistance (R _{int})	0.26664 [Ω]
FC absolute temperature (T)	343 [K]
Hydrogen time constant (τ _{H2})	3.37 [s]
Hydrogen valve constant (K _{H2})	4.22 x10 ⁻⁵ [k ^{mol} (s atm) ⁻¹]
Hydrogen-oxygen flow ratio (r _{H2O})	1.168
Kr constant =N _o /4F	2.2802 x 10 ⁻⁷ [k ^{mol} (s A) ⁻¹]
Line reactance (X)	0:0809 [Ω]
Methane reference signal (Q _{methref})	0.000015 [k ^{mol} s ⁻¹]
No load voltage (E _o)	1.18 [V]
Number of cells (N _o)	88
Number of stacks (N _s)	1
Oxygen time constant (τ _{O2})	6.74 [s]
Oxygen valve constant, (k _{O2})	2.11 x10 ⁻⁵ [k ^{mol} (s atm) ⁻¹]
PI gain constant (k _i)	0.25
Reformer time constant (τ ₁ , τ ₂ , τ ₃)	15 [s]
Universal gas constant (R)	8314.47 [J k ^{mol} K ⁻¹]
Utilization factor (U)	0.8
Water time constant (τ _{H2O})	18.418 [s]
Water valve constant (K _{H2O})	7.716 x 10 ⁻⁶ [k ^{mol} (s atm) ⁻¹]

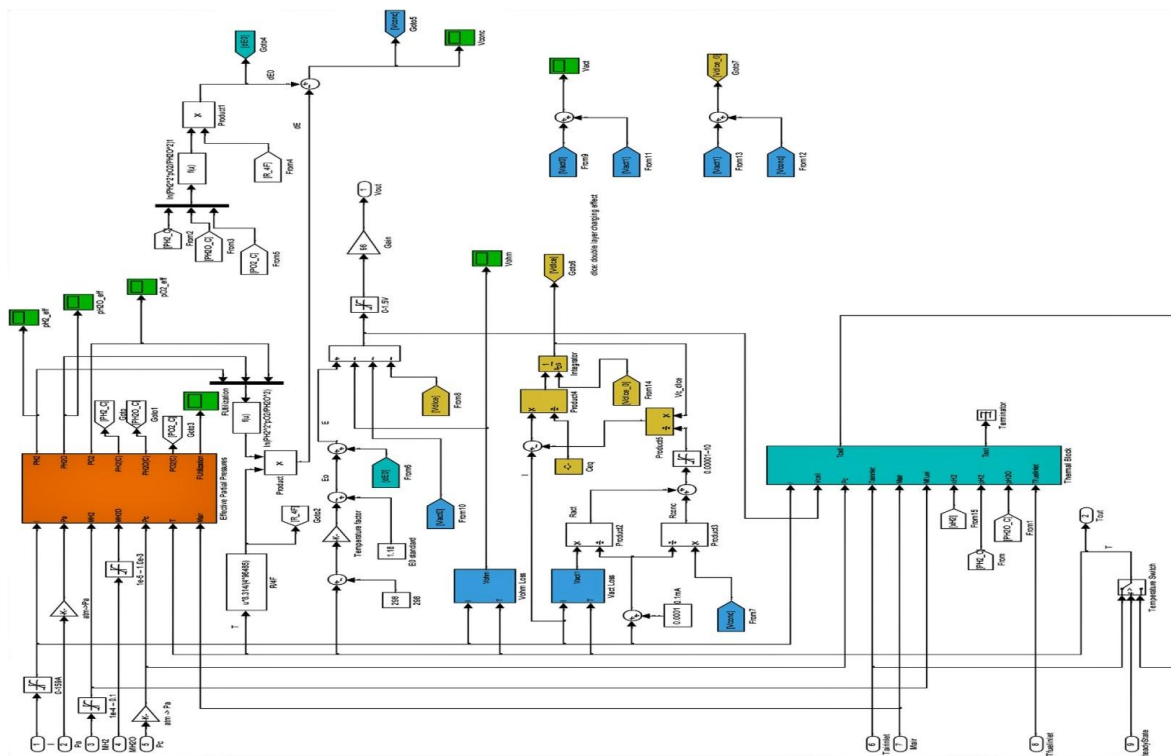

Figure 4. A brief model of SOFC system using simulink

3. CONTROL AND POWER MANAGEMENT STRATEGY

Figure 5 shows the detailed block diagram representation of proposed HES as shown in Figure 1. Figure 5(a) shows the block diagram of HES, where maximum power can be tracked from PV system with the help of MPPT. This power is utilized to fulfill the load demand and the extra power of the PV system is given to the electrolyzer, which is utilized to extract the hydrogen. This hydrogen further used as a fuel of the SOFC. The PV system with MPPT is connected to DC-DC converter (boost converter) to boost up the voltage and the boost converter is triggered by the gate pulse generated by the MPPT. Again SOFC is also connected to another boost converter to boost up the voltage of SOFC as shown in Figure 5b. The purpose of voltage source converter (VSC) is used to synchronize the system voltage with the grid voltage. So, the grid

voltage and frequency are used for the operation of DC-AC converter (Inverter). VSC consists of two control cascade loops, which are used for regulation of DC bus voltage where, first one is the voltage controller of DC-link and last one is the internal current loop.

3.1. Voltage controller of DC-link

The DC-link voltage is used to control the active power with its desired value. Output of the DC-link PI controller (i_d^*) acts as a reference of the current PI controller (active current controller) that is shown in Figure 5(c).

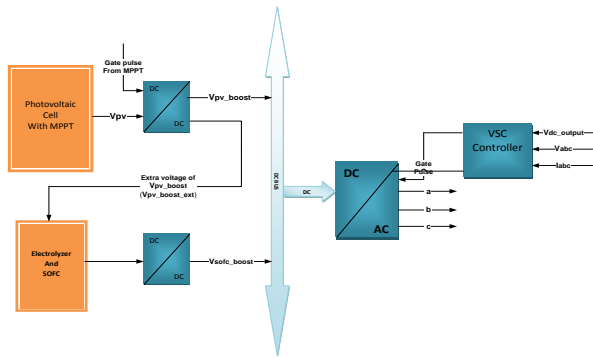

(a) Block diagram of Hybrid Energy System (HES)

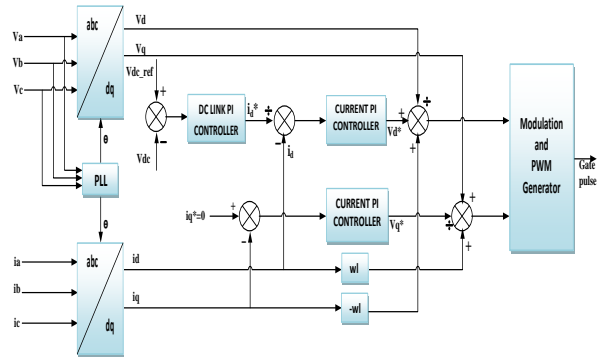

(c) Block diagram representation of Voltage Source Inverter (VSC)

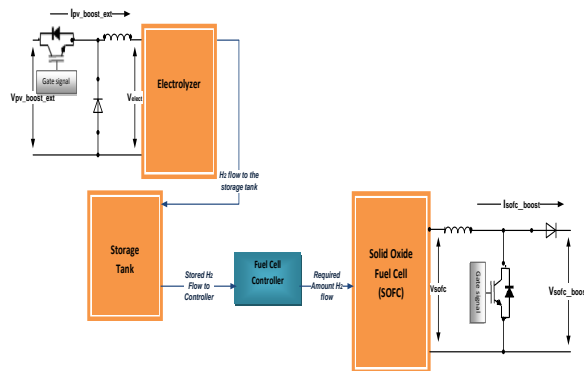

(b) Block diagram representation of Hydrogen flow from electrolyzer to SOFC

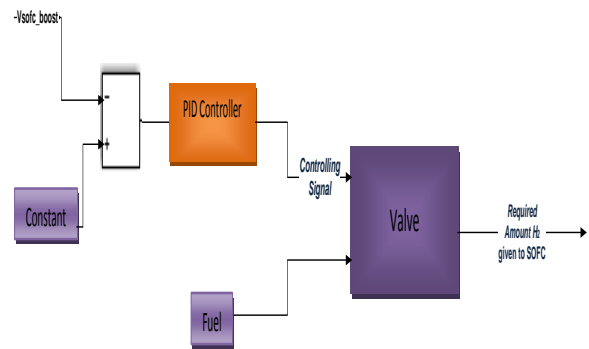

(d) Block diagram representation of Fuel Cell Controller

Figure 5. A detailed block diagram of Hybrid Energy System (HES)

3.2. Internal current loop

The $d-q$ control (synchronous reference frame) is used for transformation of grid voltage (V_a, V_b, V_c) and grid current (i_a, i_b, i_c) to $d-q$ reference frame which rotates synchronously along with grid voltage. With the help of $d-q$ control, the DC values are obtained by controlling the variables. So, the DC values are easier for design and control. Grid voltage derives the phase angle by the help of phase locked loop (PLL) which can be used for $abc \rightarrow dq$ transformation for synchronization of grid voltage with controlled current. PLL is a technique which can be used to derive the phase angle from the grid voltage. From Figure 5(c), it can be seen that a zero value is set to the reference reactive current (i_q^*). So, power factor is maintained to be one (unity). The current PI controllers provide the voltage outputs (V_d^*, V_q^*). These voltage outputs act as input of the PWM generator to produce the pulses which is used to trigger the DC-AC converter [25].

From the Figure 5(b), it can be seen that buck converter is connected across the electrolyzer. As described before the extra power of the PV system is given to the electrolyzer, where water is divided into hydrogen and oxygen and this hydrogen acts as fuel of SOFC. The requirement of the amount of hydrogen for the SOFC depends upon the load demand and the difference amount of hydrogen (hydrogen generated by

electrolyzer – hydrogen required by SOFC) is stored in storage tank. Figure 5(d) shows the block diagram of fuel cell controller, where the voltage signals of boost converter (V_{sofc_boost}) is given to the PID controller. Then, PID controller regulates the valve according to the load demand and decides how much amount of hydrogen flow to the SOFC through the valve. The values of PID controller are decided by self tuned mode ($P=0.00013317$, $I=3.3925227e-05$, $D=-6.254254172870e-05$).

3.3. Operational control strategy of HES

The neediness of the operational control strategy is to manage the relationship between the load demand and hybrid generation system. The operational control strategy follows four possible paths to manage this.

- a. When PV power (P_{pv}) is greater than load demand (P_{load}), then PV power is supplied to the load according to its requirement and the extra power of PV is supplied to the electrolyzer. By the help of this power electrolyzer divides the water into two halves (hydrogen, oxygen). Then, hydrogen is stored in the storage tank and later it is supplied to SOFC through the valve.
- b. When PV power (P_{pv}) is less than load demand (P_{load}), then PV power is not sufficient to fulfill the load demand. So, extra power is required to fulfill the load demand with the PV power and that extra power is supplied by the SOFC.
- c. When PV power (P_{pv}) is equal to the load demand (P_{load}), then total PV power is supplied to the load, no extra power of PV supplied to the electrolyzer.
- d. When PV power (P_{pv}) is equal to zero, then no PV power is supplied to the load and at that time SOFC fulfills the requirement of the load demand.

4. SIMULATION RESULTS AND DISCUSSIONS

The proposed hybrid energy system (PV/SOFC-Electrolyzer) has been designed under MATLAB/Simulink environment and also different simulations are carried out to verify the performances. Figure 6(a) shows the generation of hydrogen (H_2) by the electrolyzer with the help of electrolysis process, where extra power of PV acts as the input of the electrolyzer after fulfilling the load demand and this hydrogen is stored in storage tank. Then, the hydrogen is utilized as a fuel of SOFC. Figure 6(b) shows the flow of hydrogen (H_2) to the SOFC according to the load demand and it is controlled by the PID controller, which is shown in Figure 6(c). The obtained voltage from SOFC is boosted up by the help of DC/DC converter (boost converter) which is shown in Figure 6(d). The boosted voltage (V_{sofc_boost}) is used to fulfill the required demand, when the load demand is greater than PV power.

Figure 7 presents the voltage and current wave forms of the hybrid energy system fed to the load. Figure 8 presents the voltage, current and power wave forms of 3-phase load having the capacity of active power (P) = 8000 W, inductive power (Q_L) = 2000 VAR and capacitive power (Q_C) = 100 VAR.

From the above simulation results, it is observed that H_2 flow to the SOFC and PID controller output track the load variation perfectly. In addition, the output voltage of boost converter connected to SOFC is matched to the required voltage for the load. Further, the output voltage and current of hybrid energy system and the voltage, current and power of 3-phase load are found to be satisfactory without having unwanted distortions. So, this proposed system can fulfill approximately different load requirements, while making the cost of this system cheaper which can be affordable by the consumers. This system is also environmental friendly and provides clean energy sources.

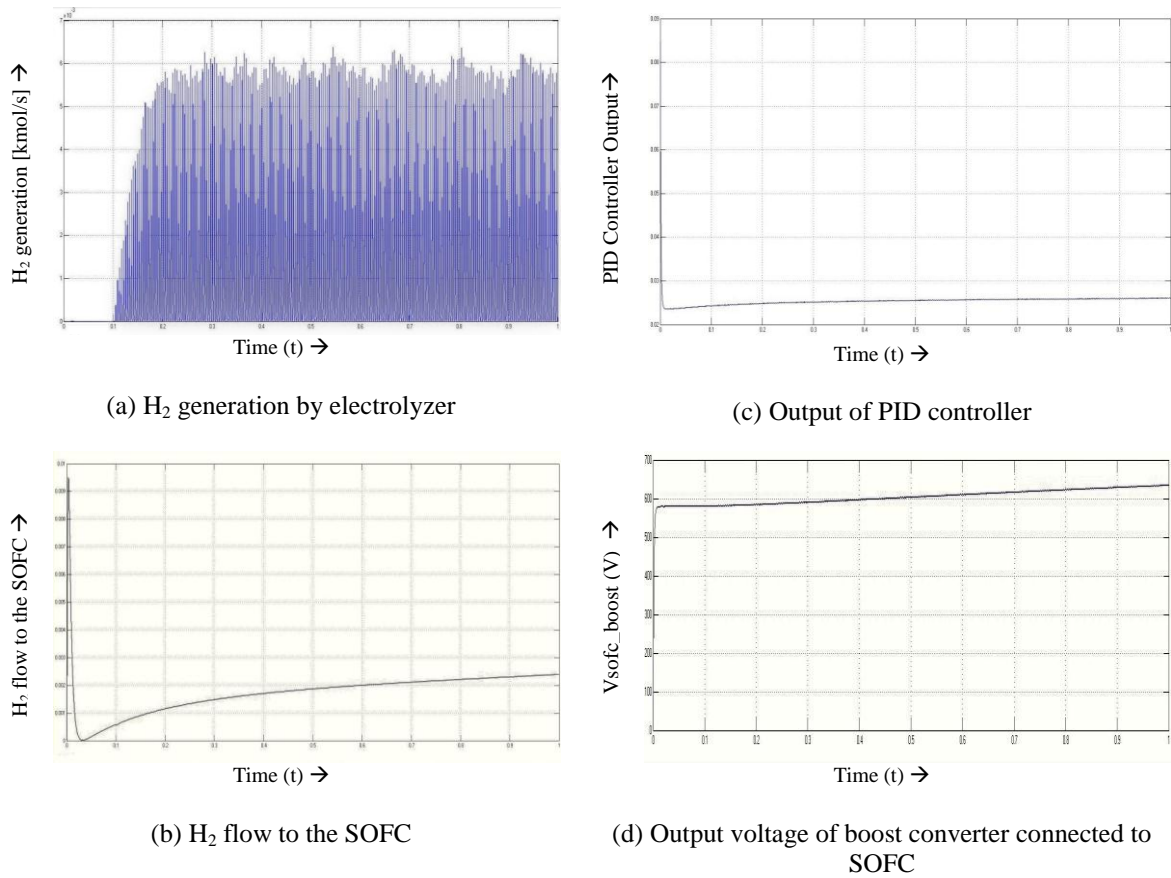

Figure 6. Detailed diagram of Hydrogen generation, control and output of boost converter connected across SOFC

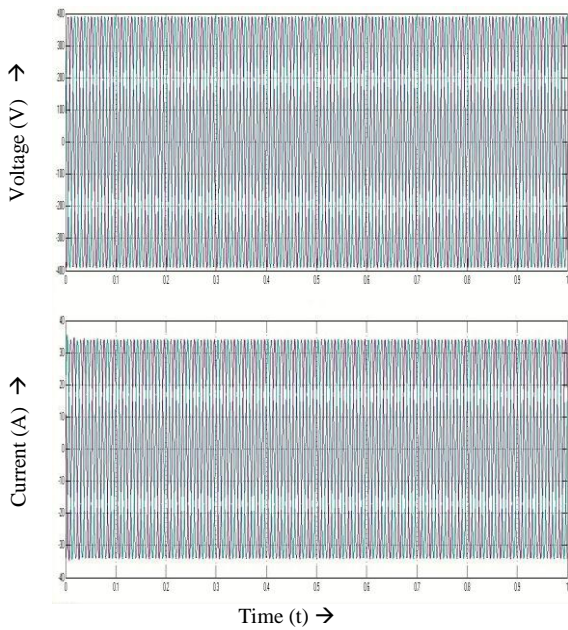

Figure 7. Output voltage and current of hybrid energy system (HES)

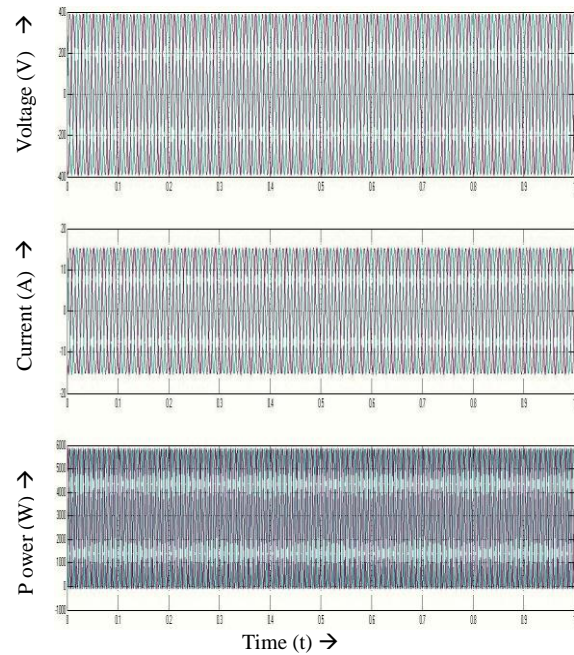

Figure 8. Voltage, current and power of 3-phase load

5. CONCLUSIONS

This paper presents detailed modeling of a hybrid energy system consisting of PV/FC/Electrolyzer combined with a storage system. Different characteristics and system configuration of the various components are given. Also power management and the overall control strategy of the hybrid energy system are represented. The PV system is the main source of power generation, after fulfillment of the load demand by the PV generation the extra power of PV is utilized to produce H₂. The SOFC takes this H₂ as a fuel and acts as back up generation. Simulations are carried out under severe conditions and the system performances are verified as well as the results are obtained which show the performance of control strategy. In this proposed system, PID controller decides the amount of hydrogen flow to the SOFC through the valve according to the power demand. Also the hybrid energy system is connected to the grid with the help of VSC which results better performances of the whole system. Further, the results are verified and found to provide satisfactory performances. Hence, a better power management strategy is obtained to fulfill the load demand under the critical and unfavorable conditions.

REFERENCES

- [1] S.Tamalouzt, *et al.*, "Performances analysis of WT-DFIG with PV and fuel cell hybrid power sources system associated with hydrogen storage hybrid energy system", *International Journal of Hydrogen Energy*, vol. 41, pp. 21006-21021, 2016.
- [2] N. Benyahia, *et al.*, "Modeling and simulation of a stand-alone wind/photovoltaic/fuel cell system associated with a hybrid energy storage", The 3rd International Renewable Energy Congress, Hammamet, Tunisia, pp. 20-22, December 2011.
- [3] Y. Bouzelata, *et al.*, "Exploration of optimal design and performance of a hybrid wind-solar energy system", *International Journal of Hydrogen Energy*, vol. 41, pp. 497-511, 2016.
- [4] H. Yang, *et al.*, "A novel optimization sizing model for hybrid solar-wind power generation system", *Journal of Solar Energy*, vol. 81, pp. 76-84, 2007.
- [5] A. Etxeberria, *et al.*, "Comparison of three topologies and controls of a hybrid energy storage system for microgrids", *Energy Conversion Management*, vol. 54, pp. 113-121, 2012.
- [6] R. Balamurugan and R. Nithya, "FC/PV Fed SAF with Fuzzy Logic Control for Power Quality Enhancement", *International Journal of Power Electronics and Drive System (IJPEDS)*, vol. 5, pp. 470-476, 2015.
- [7] B. S. Sami, "An Intelligent Power Management Investigation for Stand-Alone Hybrid System Using Short-Time Energy Storage", *International Journal of Power Electronics and Drive System (IJPEDS)*, vol. 8, pp. 367-375, 2017.
- [8] N. A. Ahmed, *et al.*, "Development of an efficient utility interactive combined wind/photovoltaic/fuel cell power system with MPPT and DC bus voltage regulation", *Electrical Power Systems Research*, vol. 81, pp. 1096-1106, 2011.
- [9] A. Maleki and A. Askarzadeh, "Comparative study of artificial intelligence techniques for sizing of a hydrogen-based standalone photovoltaic/wind hybrid system", *International Journal of Hydrogen Energy*, vol. 39, pp. 9973-9984, 2014.
- [10] S. Obara, *et al.*, "Economic efficiency of a renewable energy independent microgrid with energy storage by a sodium-sulfur battery or organic chemical hydride", *Internal Journal of Hydrogen Energy*, vol. 38, pp. 8888-8902, 2013.
- [11] R. Sarrias-Mena, *et al.*, "Electrolyzer models for hydrogen production from wind energy Systems", *International Journal of Hydrogen Energy*, vol. 40, pp. 2927-2938, 2015.
- [12] X. Liu, *et al.*, "A hybrid AC/DC micro-grid and its coordination Control", *IEEE Transactions on Smart Grid*, vol. 2, pp. 278-286, 2011.
- [13] H. Milanda, *et al.*, "Load control of a wind-hydrogen stand-alone power system", *International Journal of Hydrogen Energy*, vol. 31, 2006, pp. 1215-1235.
- [14] C. Wang and M. Hashem Nehrir, "Power management of a standalone wind/photovoltaic/fuel cell energy system", *IEEE Transactions on Energy Conversion*, vol. 23, pp. 957-967, 2008.
- [15] N. H. Samrat, *et al.*, "Modeling, control, and simulation of battery storage photovoltaic-wave energy hybrid renewable power generation systems for island electrification in Malaysia", *Science World Journal*, vol. 21, pp. 1-21, 2014.
- [16] B. V. Rajanna, *et al.*, "Solar Photovoltaic Generators with MPPT and Battery Storage in Microgrids", *International Journal of Power Electronics and Drive System (IJPEDS)*, vol. 7, pp. 701-712, 2016.
- [17] D. Rekioua, *et al.*, "Development of hybrid photovoltaic-fuel cell system for stand-alone application", *International Journal of Hydrogen Energy*, vol. 39, pp. 1604-1611, 2014.
- [18] T. Vigneysh, *et al.*, "Operation and control of wind/fuel cell based hybrid micro grid in grid connected mode", *IEEE International Multi-Conference on Automation, Computing, Communication, Control and compressed Sensing*, pp.754-758, March 2013.
- [19] S.Tamalouzt, *et al.*, "Direct torque and reactive power control of grid connected doubly fed induction generator for the wind energy conversion", *Tunisie Conference on International Sciences Technologies Electriques*, Maghreb, Tunis, pp.1-7, November 2014.

- [20] F. Tazerart, *et al.*, “Direct torque control implementation with losses minimization of induction motor for electric vehicle applications with high operating life of the battery”, *International Journal of Hydrogen Energy*, vol. 40, pp. 13827-13838, 2015.
- [21] C. N. Bhende, *et al.*, “Permanent magnet synchronous generator-based standalone wind energy supply system”, *IEEE Transactions on Sustain Energy*, vol. 4, pp. 361-373, 2011.
- [22] O. C. Onar, *et al.*, “Dynamic modeling, design and simulation of a wind/fuel cell/ultra-capacitor-based hybrid power generation system”, *Journal of Power Sources*, vol. 161, pp. 707-722, 2006.
- [23] M. Uzunoglu and O. C. Onar, “Static VAR compensator based reactive power Management for SOFC power plants”, *International Journal of Hydrogen Energy*, vol. 33, pp. 2367-2378, 2008.
- [24] G. K. Bayrak and M. Cebeci, “Grid connected fuel cell and PV hybrid power generating system design with Matlab Simulink”, *International Journal of Hydrogen Energy*, vol. 39, pp. 8803-8812, 2014.
- [25] M.G.Molina and E.J.Espejo, “Modeling and simulation of grid-connected photovoltaic energy conversion systems”, *International Journal of Hydrogen Energy*, Vol. 39, pp. 8702-8707, 2014.

BIOGRAPHIES OF AUTHORS



Sujit Kumar Bhuyan was born in Odisha, India in 1984. He has graduated in Electrical Engineering in 2007 and received his M.Tech in Power System and Control Engineering in 2012 both from BPUT, Rourkela (India). He is a Ph.D research scholar at KIIT University, Bhubaneswar, India. Currently, he is an Assistant Professor of Electrical Engineering Department at Bhadrak Institute of Engineering and Technology, Bhadrak under BPUT, Rourkela (India). His research interests include Renewable Energy Generation Systems, Power Electronics Converters and Inverters, Hybrid Energy System Simulation and Optimization, Power Quality, etc.



Prakash Kumar Hota was born in 1963 in India. He has graduated in Electrical and Electronics Engineering from the National Institute of Technology (NIT), Tiruchirapalli, India in 1985, received his M.Tech in Industrial Power Control & Electric Drives in 1992 from Sambalpur University, India and Ph.D in Electrical Engineering from Jadavpur University, Kolkata, India in 1999. Currently, he is a Professor of Electrical Engineering and Dean of Centre for Distance and Continuing Education (CDCE) at Veer Surendra Sai University of Technology (VSSUT), Burla, India. His research interests include Economic Emission Load Dispatch, Hydrothermal Scheduling, Hybrid Power Generation Systems, Power Quality and Soft Computing applications to different Power System Problems in Deregulated Environment.



Bhagabat Panda received the Ph.D degree from Utkal University, M.Tech degree in Power System Engineering from VSSUT Burla, B.Tech degree in Electrical Engg from VSSUT Burla, Sambalpur, Odisha. Currently, he is an Associate Professor at School of Electrical Engineering of KIIT University, Bhubaneswar. His research interests include Distributed Generation, Renewable Energy, Micro Grid and Smart Grid as well as Power Electronics application to Electric Power Systems.