

Model to Evaluate the Performance of Building Integrated Photovoltaic Systems using Matlab/Simulink

Julián Andrés Camacho Castro, Andrés Julián Aristizábal Cardona

Engineering Department, Universidad de Bogotá Jorge Tadeo Lozano, Bogotá, Colombia

Article Info

Article history:

Received Oct 29, 2017

Revised Dec 28, 2017

Accepted Jan 8, 2018

Keyword:

Matlab software

Photovoltaic systems

PV performance model

Radiation and temperature

Solar energy

ABSTRACT

This article describes a mathematical model implemented in Matlab/Simulink to evaluate the performance of building integrated photovoltaic systems (BIPVS). The proposed methodology allows to model independently the solar panel, the photovoltaic (pv) generator, inverter and the grid to integrate them into a single model in Simulink in order to evaluate the performance of the complete system. The validation of the model was made on a BIPV system of 6 kWp installed in a building at the Universidad de Bogotá Jorge Tadeo Lozano in Bogota, Colombia. The results indicate that there is a correlation greater than 0.9 between DC and AC power generated by the BIPV system and calculated by the model proposed for any weather condition.

Copyright © 2018 Institute of Advanced Engineering and Science.
All rights reserved.

Corresponding Author:

Andrés Julián Aristizábal Cardona,
Engineering Department,
Universidad de Bogotá Jorge Tadeo Lozano,
Carrera 4 #22-61, Bogotá, Colombia.
Email: andresj.aristizabalc@utadeo.edu.co

1. INTRODUCTION

Besides being a renewable and pollution free energy generation technology with no moving parts, PV modules can also be integrated into buildings as BIPV systems, adding aesthetic value [1]. When installed in an optimized way, BIPV systems can reduce heat transferred through the envelope and reduce cooling load components decreasing the CO₂ emissions [2]. Apart from some facade installations, the rooftop segment represented more than 23 GWp of total installations in 2015, with projections of more than 35 GWp to be installed by 2018 [3].

Since the BIPV offers the possibility to replace part of the traditional building material, with a possible price reduction in comparison to a classic rooftop installation [4], [5], the correct estimation of system level performances, system reliability and system availability is becoming more important and popular among installers, integrators, investors and owners; with this purpose several tools and models were developed [6-8]. The combination of different phenomena, such as the solar radiation available on site, the presence of dust, the shadowing or UV radiation over long outdoor exposure, affect in different ways the performance of BIPV systems and thus the related economic evaluations [9-11].

Many studies have been devoted to develop different non-linear electric models used to describe the characteristics of the PV modules and the effect on module performance of temperature, radiation intensity and other parameters and equipment/systems under non-standard conditions [12-20]. We offer a new method to model and analyze the performance of BIPV systems using Matlab/Simulink.

In Section 2 of this article the mathematical description of the proposed model is presented to evaluate the performance of BIPV systems. Subsequently, Section 3 describes the 6 kW BIPV system installed. Section 4 presents the results obtained and the validation of the model with monitored data of the BIPV system. Finally, Section 5 presents the conclusions of the research carried out.

2. RESEARCH METHOD

2.1. Photovoltaic Generator Model

2.1.1. Solar Cell Model

Figure 1 shows the model adopted for the solar cell [25-28]; which is widely used due to its simplicity and high degree of precision.

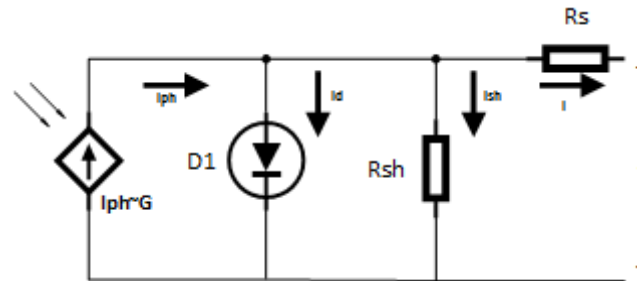

Figure 1. Equivalent single-diode circuit of a solar cell

Using circuit theory, the relation of the currents in the circuit can be obtained, which is given by:

$$I = I_{ph} - I_d - I_{sh} \quad (1)$$

Where I_{ph} represents the photo current generated which is directly proportional to the incident irradiance (G) and depends in less proportion on the operating temperature of the cell (T). This current can be expressed by the following equation:

$$I_{ph} = [I_{sc} + K_i * (T - T_r)] * \frac{G}{G_r} \quad (2)$$

Where I_{sc} is the short-circuit current under standard conditions ($STC = 1000W/m^2$, $25^\circ C$, $AM1.5$) and T_r and G_r are the temperature and irradiance also in STC , K_i is the short-circuit temperature coefficient of the cell.

The diode current I_d represents the effect of the diffusion and recombination currents present at the PN junction of the cell. The most used mathematical model that allows to approximate the behavior of the diode is the Shockley equation that is given by:

$$I_d = I_s * \left(e^{\left(\frac{q*V_d}{n*k*T} \right)} - 1 \right) \quad (3)$$

In which $q = 1.602 \times 10^{-19} C$ is the charge of the electron, n is the diode ideal factor, dependent on the manufacturing process and usually adopts values between 1 (for germanium) and 2 (for silicon), $k = 1.3806 \times 10^{-23} J/k$ is the Boltzmann constant, which relates absolute temperature and energy, V_d is the voltage at the terminals of the diode and I_s is the saturation current of the cell, and is represented by the following equation:

$$I_s = I_{rs} * \left(\frac{T}{T_r} \right)^3 * e^{\left[\left(\frac{q*E_{bg}}{n*k} \right) * \left(\frac{1}{T_r} - \frac{1}{T} \right) \right]} \quad (4)$$

Where $E_{bg} = 1.12 eV$ is the bandwidth energy (in this case for silicon), and I_{rs} is the inverse saturation current at standard temperature given by:

$$I_{rs} = \frac{I_{sc}}{e^{\left(\frac{q*V_{oc}}{N_s*k*n*T} \right)} - 1} \quad (5)$$

Where V_{oc} represents the cell's open circuit voltage.

Finally, I_{sh} represents the leakage current through the junction and this is represented by the parallel resistance R_{sh} .

The leakage current is given by:

$$I_{sh} = \frac{V_d}{R_{sh}} \quad (6)$$

Where,

$$V_d = V + I * R_s \quad (7)$$

Where V is the output voltage of the cell and Rs is the series resistance that represents the ohmic losses in the contacts due to the metal-semiconductor junction. Finally the following expression for Ish is obtained as:

$$I_{sh} = \frac{V+I*R_s}{R_{sh}} \quad (8)$$

Modifying expression (1) with Equations (3) and (8) gives the equation of the simple diode model for the solar cell to be used for the final model:

$$I = I_{ph} - I_s * \left(e^{\left(\frac{V+R_s*I}{n*V_t} \right)} - 1 \right) - \frac{V+R_s*I}{R_{sh}} \quad (9)$$

2.1.2. Photovoltaic Module Model

The next step is to scale the model to an array because the power of a single cell is very small for general purposes. Generally the solar modules connect several cells in series (Ns) to produce more voltage and in parallel (Np) to produce more current. The following parameters were considered for scaling to a module:

$$I_M = N_p * I \quad (10)$$

$$I_{scM} = N_p * I_{sc} \quad (11)$$

$$V_M = N_s * V \quad (12)$$

$$V_{ocM} = N_s * V_{oc} \quad (13)$$

$$R_{sM} = R_s * N_s \quad (14)$$

$$R_{shM} = R_{sh} * N_s \quad (15)$$

To represent a photovoltaic panel it is necessary to modify Equation (9) taking into account Equations (10) to (15) as follows:

$$I = N_p * I_{ph} - N_p * I_s * \left(e^{\left(\frac{V+R_s*I*\left(\frac{N_s}{N_p}\right)}{n*V_t*N_s} \right)} - 1 \right) - \frac{V+R_s*I*\left(\frac{N_s}{N_p}\right)}{R_{sh}*\left(\frac{N_s}{N_p}\right)} \quad (16)$$

Taking into account that for the model to develop $N_p = 1$ the expression can be reduced as follows:

$$I = I_{ph} - I_s * \left(e^{\left(\frac{V+R_{sM}*I}{V_t*N_s*n} \right)} - 1 \right) - \frac{V+R_{sM}*I}{R_{shM}} \quad (17)$$

The Rs and Rsh values are not supplied by the manufacturer, but an approximate value of these values can be obtained by the following expressions:

$$R_{smax} = \frac{V_{oc}-V_{mpp}}{I_{mpp}} \quad (18)$$

$$R_{sh_{min}} = \frac{V_{mpp}}{I_{sc} - I_{mpp}} - R_s \tag{19}$$

By means of iterative methods it is possible to obtain more approximate values of these resistances starting from the expressions (18) and (19). Some authors recommend using values as R_s less than 0.01Ω and values of R_{sh} greater than 500Ω .

The Newton-Raphson method is used because of the exponential nature of Equation (17), which must be solved, by using numerical methods such as the one mentioned above [29]. The output variables of the photovoltaic panel are produced with a vector from the open circuit voltage (V_{oc}) and the power obtained (P).

Once the equation of G vs V_{mpp} is obtained, it is implemented in the algorithm and the model is scaled to a complete generator taking into account the following relations:

$$I_G = N_{pG} * I_M \tag{20}$$

$$V_G = N_{sG} * V_M \tag{21}$$

$$P_G = I_G * V_G \tag{22}$$

Where I_G , V_G and P_G represent the current, voltage and power of the solar generator respectively, N_{pG} represents the number of modules connected in parallel and N_{sG} represents the number of modules connected in series.

2.2. Inverter Model

The model proposed by Castañer [25] shown in Figure 2 is taken as reference.

It is important to clarify that the inverters have incorporated the maximum power point (MPPT) tracker described above but the present model has been simplified since the generator model already delivers the values of V_{mpp} and I_{mpp} which are received through the resistors $R1$ and $R2$. The product of the voltage values in the resistors replicates the values of P_{mpp} given by the irradiance and the temperature in a certain period of time. In turn this product must be multiplied by the value of the efficiency of the inverter (η) provided by the manufacturer. The controlled voltage source $V1$ must provide the sinusoidal amplitude values of the output current whereby the previously calculated power value must be divided by the voltage value provided by the electrical grid at V_{RMS} due to being treated in power at DC as shown in the following relation:

$$I_{RMS} = \frac{V_{mpp} * I_{mpp} * \eta f}{V_{red_{RMS}}} \tag{23}$$

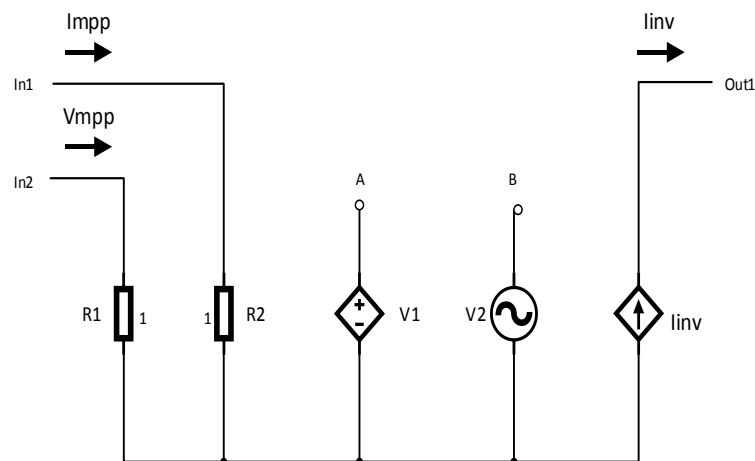

Figure 2. Equivalent circuit of the inverter model

Since it is an efficient current, it is necessary to obtain the peak current values to obtain the amplitude values of the source $V1$ as shown in Equation (24):

$$V_1 = \frac{V_{mpp} * I_{mpp} * n_f * \sqrt{2}}{V_{red_{RMS}}} = I_{p-p} \quad (24)$$

The amplitude values obtained in V_1 are used in the controlled current source I_{inv} by multiplying them by a sinusoidal signal (V_2) which has the frequency and phase of the current provided by the electrical grid and a amplitude of 1V in order to obtain the corresponding waveform of the AC output current of the inverter.

2.3. Electrical Grid Model

The model used to simulate the power grid can be seen in Figure 3.

It is an RLC circuit whose main characteristic must be having a power factor greater than or equal to 0.85 as established by the IEEE 929-2000 standard [30]. To meet such a requirement, an impedance value is first set to the appropriate angle set by Equation (25).

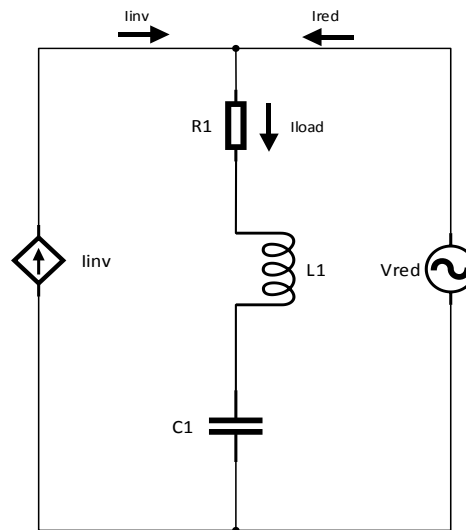

Figure 3. RLC circuit representing the local electrical grid

$$\theta = \arccos(0.85) = 31.7^\circ \approx 30^\circ \quad (25)$$

Taking expression (26) into account, a value is established for $R = 3\Omega$ and $X = \sqrt{3}$. The values of the inductive reactance (X_L) and capacitive (X_C) are calculated considering the expressions (27) and (28) at a frequency of 60Hz.

$$\tan\theta = \frac{(X_L - X_C)}{R} = \frac{\sqrt{3}}{3} \quad (26)$$

$$X_C = \frac{1}{2 * \pi * f * C} \quad (27)$$

$$X_L = 2\pi f L \quad (28)$$

An inductance value of $L = 2H$ is established for the purpose of having a positive reactive power and the expression (29) is used to obtain the value of the capacitance (C) where $\omega = 2\pi f L$ [43].

$$C = \frac{1}{\omega^2 L - \omega \sqrt{3}} = 3.526 * 10^{-6} F \quad (29)$$

Once the development of all the components of the interconnected system has been completed, they are integrated into a single model (Figure 4), which will allow obtaining the behavioral results that represent the interaction of the different functional blocks.

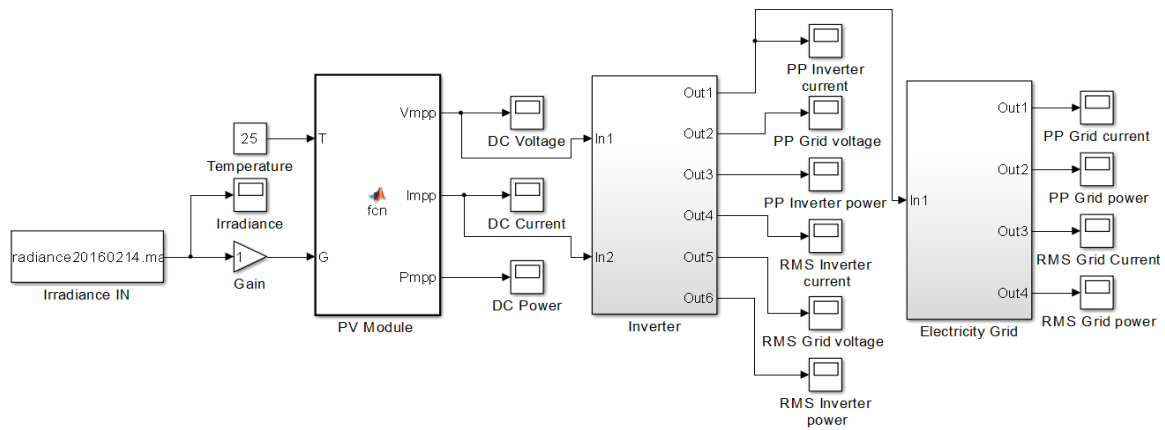

Figure 4. Complete model of the photovoltaic system interconnected to the grid implemented in Simulink.

3. SYSTEM DESCRIPTION

The grid-connected BIPV system installed at the Universidad de Bogotá Jorge Tadeo Lozano includes a PV array of 24 modules of poly crystalline silicon (Trina Solar TSM-PA05.08), each one of 250 Wp and an inverter Sunny Boy 5000-US model of 5000 W.

Taking into account that the DC input of the SB 5000-US inverter varies between 175 V and 480 V and the voltage at maximum power point (VMPP) of the module is 38V, the PV array was built interconnecting 2 branches in parallel of 12 modules in series each one. Under these conditions the nominal power of the PV array is 6000 Wp.

The PV system is fully monitored to evaluate and analyze the energy produced and the power quality, since September 2015. The electrical variables are acquired every minute for every day and are stored in a spreadsheet file and they will be compared with the simulation results using Matlab.

4. RESULTS AND ANALYSIS

4.1. Photovoltaic Generator

In order to evaluate the different characteristics of the module, the simulation is performed under different environmental conditions. Then, we maintain the operating temperature of the module (T) constant and we vary the irradiance (G) at different levels; the results obtained are shown in Figure 5(a) and Figure 5(b).

As can be seen in Figure 5(a) and Figure 5(b), there is a strong relationship of the short-circuit current (Isc) with the increase of the incident irradiance (G). Open circuit voltage (Voc) is less sensitive.

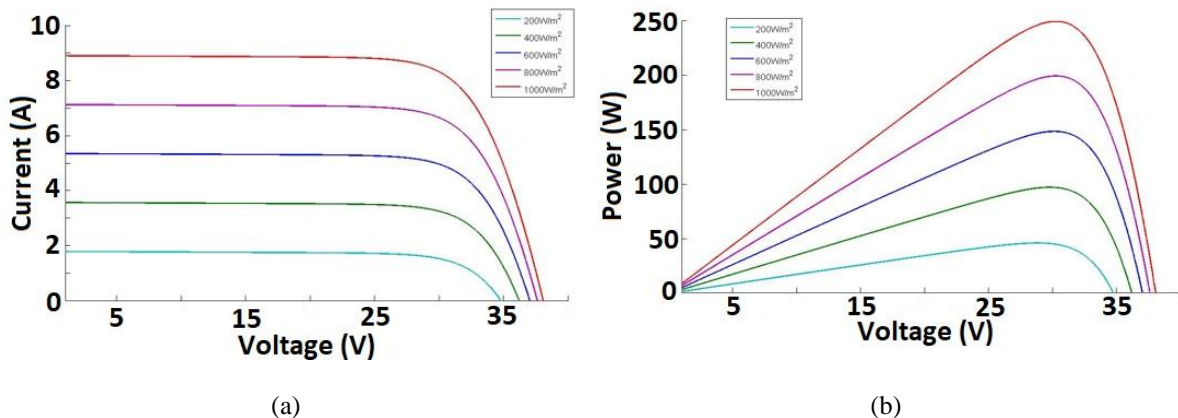

Figure 5. (a) I-V curves, effect of irradiance at constant temperature of 25°C and (b) P-V curves, effect of irradiance at constant temperature of 25°C

For 800 W/m^2 , the current recorded was 7.2 A with an open circuit voltage of 37.5 V . For standard solar radiation of 1000 W/m^2 , the current obtained was 8.86 A and an open circuit voltage of 37.8 V . For the same level of solar radiation, the solar panel manufacturer reported a short-circuit current of 8.91 A and open circuit voltage of 38.1 V . This difference represents an error of 0.5% between the data generated by the model developed in Matlab™ and data reported by the manufacturer.

Maximum power point in P-V curves:

- For a solar radiation level of 200 W/m^2 and 25°C of temperature, the open circuit voltage was 29.5 V and 48 W of DC power.
- For a solar radiation level of 1000 W/m^2 and 25°C of temperature, open circuit voltage was 30 V and 248 W of DC power.
- The percentage error between the maximum power point of the solar module reported by manufacturer and delivered by the model with 1000 W/m^2 and 25°C , was 0.8% .

Figure 8(a) shows the comparison between the DC voltage of the photovoltaic generator measured by the monitoring system with the same voltage delivered by the model in Matlab. Figure 8(b) shows the comparison between the AC power of the photovoltaic generator measured by the monitoring system with the AC power delivered by the model in Matlab.

The Matlab model has a voltage of 300 V at $6:39 \text{ am}$; while the monitoring system registers a value of 355 V for the same hour. The maximum voltage reached by the solar panels is presented at $5:05 \text{ pm}$ with a value of 410 V . The correlation coefficient calculated between the DC voltage measured and that delivered by the model was 0.96 .

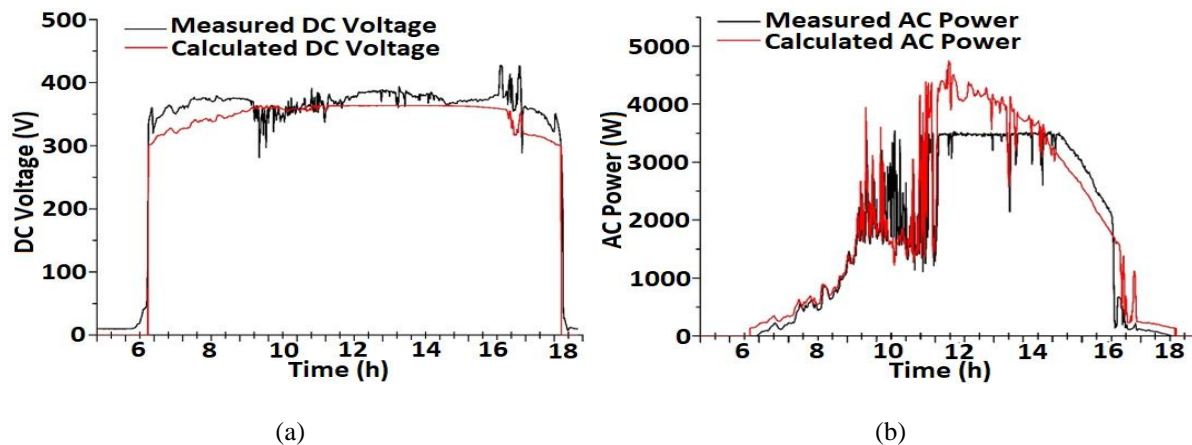

Figure 8. (a) Monitored DC voltage and DC voltage of the model on a sunny day and (b) Monitored AC rms power and AC rms power of the model on a sunny day

5. CONCLUSIONS

In the present work the proposed model of a photovoltaic system interconnected to the electrical grid has been developed using the MATLAB/Simulink tool. The study has been carried out including the equivalent circuits of the fundamental components of its basic structure and analyzed under monitored irradiance conditions supplied by a measurement unit located in the facilities of an installed system.

The complete model has been analyzed by means of a comparison of the nominal values of the modules and the inverter given by the manufacturers with respect to the data delivered by the model and a high degree of approximation was found, which suggests an adequate behavior compared to the standard conditions.

The values of the model variables were compared with monitored measurements made at the Universidad de Bogota Jorge Tadeo Lozano with different irradiance characteristics and correlation coefficients with values higher than 0.92 were found, which confirms an adequate behavior of the model, very close to the monitored behavior of the pv system installed.

ACKNOWLEDGEMENTS

This work was carried out with the financial support of the researching project 633-11-14 from Universidad de Bogotá Jorge Tadeo Lozano.

REFERENCES

- [1] D. Prasad, M. Snow, "Designing with Solar Power-A Source Book for Building Integration Photovoltaics (BiPV)", Images Publishing, Australia, 2002.
- [2] M.S. ElSayed, "Optimizing thermal performance of building-integrated photovoltaics for upgrading informal urbanization", *Energy Build.* 116 (2016) 232–248.
- [3] EPIA European Photovoltaic Industry Association, *Global Market Outlook for Photovoltaics 2014–2018*, Brussels, Belgium, 60 p. (2014).
- [4] Campoccia, A., Dusonchet, L., Telaretti, E., Zizzo, G., 2014. "An analysis of feed-in tariffs for solar PV in six representative countries of the European Union". *Sol. Energy* 107, 530–542.
- [5] James, T., Goodrich, A., Woodhouse, M., Margolis, R., Ong, S., 2011. "Building-integrated photovoltaics (BIPV) in the residential sector: an analysis of installed rooftop system prices". *Energy*, 50.
- [6] Chin, V.J., Salam, Z., Ishaque, K., 2015. "Cell modelling and model parameters estimation techniques for photovoltaic simulator application: a review". *Appl. Energy* 154, 500–519.
- [7] Lo Brano, V., Ciulla, G., Falco, M.Di., 2014. "Artificial neural networks to predict the power output of a PV panel". *Int. J. Photoenergy* 2014.
- [8] Zhou, W., Yang, H., Fang, Z., 2007. "A novel model for photovoltaic array performance prediction". *Appl. Energy* 84, 1187–1198.
- [9] A. Chica, F. Rey and J. Aristizábal. "Application of autoregressive model with exogenous inputs to identify and analyse patterns of solar global radiation and ambient temperature". *International Journal of Ambient Energy* 2012; 33 (4): 177-183.
- [10] Aristizábal J., Gordillo G. "Performance and economic evaluation of the first grid - connected installation in Colombia over 4 years of continuous operation". *International Journal of Sustainable Energy* 2011; 30 (1): 34-46.
- [11] A.J. Aristizábal, C.A. Páez. "Experimental investigation of the performance of 6 kW BIPV system applied in laboratory building". *Energy and Buildings* 2017; 152: 1-10.
- [12] Hicham Bahri, Mohamed Aboulfatah, M'hammed Guisser, Elhassane Abdelmounim, Mohammed El Malah, "Integral Backstepping Control for Maximum Power Point Tracking Factor of a Three Phase Grid Connected Photovoltaic System", *International Journal of Electrical and Computer Engineering*, Vol. 7, no. 4, pp. 1671-1680, August 2017.
- [13] Mustapha Elyaqouti, Lahaoussine Bouhouch, Ahmed Ihal, "Modelling and Predicting of the Characteristics of a Photovoltaic Generator on a Horizontal and Tilted Surface", *International Journal of Electrical and Computer Engineering*, Vol. 6, no. 6, pp. 2257-2576, December 2016.
- [14] Amirullah, Agus Kiswantono, "Power Quality Enhancement of Integration Photovoltaic Generator to Grid under Variable Solar Irradiance Level Using MPPT-Fuzzy", *International Journal of Electrical and Computer Engineering*, Vol. 6, no. 6, pp. 2629-2642, December 2016.
- [15] Murari Lal Azad, Pradip Kumar Sadhu, Soumya Das, Biplab Satpati, Anagh Gupta, P. Arvind, Riya Biswas, "An Improved Approach to Design a Photovoltaic Panel", *Indonesian Journal of Electrical Engineering and Computer Science*, Vol. 5, no. 3, pp. 515-520, March 2017.
- [16] Syafii, Roni Putra, Hasdi Putra, "Online Monitoring of Grid Connected Residential Photovoltaic System using Zigbee and Web Server", *Indonesian Journal of Electrical Engineering and Computer Science*, Vol. 7, no. 3, pp. 668-675, September 2017.
- [17] Adnane Hassani, Mountassar Maamoun, Rezki Tadrist, Ali Nesba, "A New High Speed and Accurate FPGA-based Maximum Power Point Tracking Method for Photovoltaic Systems", *International Journal of Power Electronics and Drive Systems*, Vol. 8, no. 3, pp. 1335-1344, September 2017.
- [18] Jia Cunliang, Wang Yanxiang, Wang Zerong, "Photovoltaic Array Maximum Power Point Tracking Based on Improved Method", *TELKOMNIKA (Telecommunication Computing Electronics and Control)*, Vol. 14, no. 2, pp. 404-410, June 2016.
- [19] M. Satyanarayana, P. Satish Kumar, "Analysis and Design of Solar Photovoltaic Grid Connected Inverter", *Indonesian Journal of Electrical Engineering and Informatics*, Vol. 3, no. 4, pp. 199-208, December 2015.
- [20] Chandani Sharma, Anamika Jain, "Entrepreneurship Through Start-ups in Hill Areas Using Photovoltaic Systems", *Bulletin of Electrical Engineering and Informatics*, Vol. 6, no. 2, pp. 105-121, June 2017.
- [21] L. Castañer, de Modelling Photovoltaic System using PSpice, Barcelona, España, Jhon Wiley & Sons, LTDA, 2002, pp. 41-101, 215-242.
- [22] J. R. Mahmood, "Four MATLAB-Simulink models of photovoltaic system", *International Journal of Energy and Environment*, vol. 7, n° 5, pp. 1-10, 2016.
- [23] S.M.A.Faisal, "Model of Grid Connected Photovoltaic System Using MATLAB/SIMULINK", *Journal of Electrical Engineering*, vol. 1, n° 1, pp. 1-10, 2012.
- [24] S. Bana, "A mathematical modeling framework to evaluate the performance of single diode and double diode based SPV system", *Elsevier*, vol. 1, n° 1, pp. 1-16, 2016.
- [25] J. E. B. Bolivar, "El metodo Newton-Raphson - La alternativa del ingeniero para resolver sistemas de ecuacion no lineales", *Scientia et Technica*, vol. 11, n° 27, pp. 221-224, 2005.
- [26] IEEE, "IEEE Recommended Practice for Utility Interface of Photovoltaic (PV) System", IEEE, 2000.

BIOGRAPHIES OF AUTHORS

Julián Andrés Camacho Castro is an Electronics Engineer from the Central University, Bogota Colombia. He has participated in research projects about artificial intelligence. He has obtained his master's degree in Sustainable Energy Management from Universidad de Bogotá Jorge Tadeo Lozano in October of 2017. His areas of interest are electronic instrumentation, renewable energy systems, control and robotics.



Andrés Julián Aristizábal Cardona received the Ph.D degree in science – physics from Universidad Nacional de Colombia, Bogotá, Colombia, in 2008. He is currently the director of the Master's Degree in Engineering - Sustainable Management of Energy, in Universidad Jorge Tadeo Lozano, Bogotá, Colombia. His areas of interest are photovoltaic solar energy, virtual instrumentation, power quality and sustainability.