

Application of PST Source based DC Link Restoration for IDVR

Ramchandra Nittala¹, Alivelu M. Parimi², K. Uma Rao³

^{1,2}Department of Electrical Engineering, BITS Pilani Hyderabad Campus, India

³Department of Electrical and Electronics Engineering, RV College of Engineering, India

Article Info

Article history:

Received Jul 15, 2016

Revised Mar 13, 2017

Accepted Mar 27, 2017

Keyword:

Interline dynamic voltage

resorter (IDVR)

Phase shifting transformers

Power quality

Voltage sag

ABSTRACT

Interline Dynamic Voltage Restorer (IDVR) comprises of several Dynamic Voltage Restorers (DVRs) connected to different distribution feeders in the power system sharing common energy storage. One of the DVR provides for voltage sag compensation appearing in that feeder, while the other DVRs restore the energy in the common dc-link thus dynamically maintaining the voltage of DC link capacitor constant by importing power from the other feeders. Restoration of the DC link energy plays an important role in the capability of the individual DVR in the IDVR to mitigate deep sags with long durations. In this paper the restoration of the DC link energy of the IDVR is achieved by the utilizing the phase shifting transformers (PST) which assist the respective DVR during its power control mode. A controlled switching action is provided to choose the appropriate connection of PST to the feeders depending upon the voltage sag condition. The proposed novel concept is examined in a test power system with IDVR.

Copyright © 2017 Institute of Advanced Engineering and Science.

All rights reserved.

Corresponding Author:

Ramchandra Nittala,

Department of Electrical Engineering,

BITS Pilani Hyderabad Campus,

Jawahar Nagar, Shammerpet,

Hyderabad, Telangana, India.

Email : nittala1988@gmail.com

1. INTRODUCTION

The effective function of sensitive loads is dependent on the quality of power delivered to it and quantified in terms of its efficiency, security and reliability of loads connected to the same distribution line. The loads connected on the same end are diversified from electronically controlled loads to heavy machinery. These cause minor to major power quality issues on the distribution system. However the electronic equipment loads are more affected with the power quality problems[1]. The major power quality problem considered is voltage sag which eventually cause disruption in the performance of the load, raise in temperature, and damage to equipment etc. They are many methods exist to mitigate the voltage sag [2], but because of their limits like limited voltage capability and creating additional losses they are substituted with custom power devices. The customer power devices can also be called as Flexible AC Transmission System (FACTS) [3]. FACTS devices are connected to the transmission as well as distribution side. Among the FACTS devices connected at the distribution side, the dynamic voltage restorer (DVR) device [4-6] is used for voltage-sag and harmonics mitigation. DVR injects series voltage into the incoming network. The injection of voltage implies supplying real power into the system. An external energy source provides the real power via DC link. The external source may be capacitor bank, battery, any DC source. Thus, with deeper or longer voltage sags, more amount of energy is required. Therefore when there is long or deep voltage sags, DVR requires large external energy. This is a main problem for DVR because huge external energy involves more investment cost. This limitation can be overcome with Interline Dynamic Voltage Restorer (IDVR).

The IDVR system comprises of several DVRs connected to different feeders with a common DC link. IDVR can be used for multiple feeder voltage sag mitigation while restoring the energy at the DC link [7].

Literature on IDVR presents different methods for restoring the DC energy. Mahinda et.al [7] have introduced a control strategy which shifts the angle of the considered DVR voltages so that the DC link energy is restored with increase of real power in the feeder. They have also proposed a multi loop control systems for shifting phase angle of necessary reference signal voltages [8]. Ahmed et.al [9] proposed a virtual impedance to compensate the energy of DC link. The authors also proposed an IDVR model to improve displacement factor by the exchange of real and reactive power between the feeders and IDVR [10]. Carl et.al [11] designed a control strategy to increase the phase shift of DVR voltages. Thereby the real power in the feeder increases. This increment in real power is fed to the DC link. P. Usha Rani has proposed a Space vector modulation technique for IDVR to mitigate voltage sag [12]. P Vasudevanaidu et.al [13] have proposed a method of optimal phase angle jump computed by particle swarm optimization method to reduce the VA rating of the IDVR. Masoud Shahabadini et.al have designed cascaded H-bridge inverter which reduces load power factor under sag condition so that compensation capacity is reduced [14]. According to the literature, the main research on IDVR is focused on the restoration of its DC link energy. In this paper it is proposed to utilize a Phase Shifting Transformers (PST) to replenish the energy at the DC link in between the two DVR's of IDVR.

As, the PST can be connected to only a healthy feeder, based on the sag condition the suitable feeder to which the PST is to be connected for the restoration of DC link energy is selected through a proposed controlling algorithm. If the DC link energy cannot be restored from PST, the energy to IDVR for voltage sag mitigation should be supplied from the DC link itself. For this purpose the DC link has to be initially charged to some voltage. Hence, if the energy for voltage sag mitigation is provided by PST, the DC link voltage will remain constant. The following sections in this paper are related to the theory of IDVR, control system of IDVR, Phase Shifting Transformers, and the simulation results.

2. INTERLINE DYNAMIC VOLTAGE RESTORER

A two feeder IDVR is illustrated in Figure 1 where two DVRs are connected to two different feeders sharing a common DC link. Two different voltage sources V_{s1} and V_{s2} are fed to two feeders. Z_{L1} and Z_{L2} are the impedances connected in series to V_{s1} and V_{s2} respectively. V_{b1} and V_{b2} are the bus voltages of the two buses. The sensitive loads connected to feeder 1 and feeder 2 are represented as Load 1 and Load 2. The load voltages of the two feeders are assumed to be V_{l1} and V_{l2} respectively. IDVR is connected to the two feeders near the loads with the aid of series injection transformers as shown in Figure 1. The building blocks of two DVRs of IDVR are voltage source inverters (VSI). The diagram of the two feeders considered here is a 3 phase network which is connected to 3 single phase loads on each feeder. Voltage sag mitigating in one feeder involves transfer of real power into the system by IDVR. This real power is obtained from the second feeder (healthy feeder) through the DC link. Hence it is very essential to examine the real power when IDVR is mitigating voltage sag. This is observed from the energy of DC link whose voltage is maintained constant throughout the mitigation of sag to indicate the exchange of power between the two feeders. In the event when healthy feeder is unable to supply the required power, to compensate the sag, energy is drawn from the DC link. Hence the DC link is charged initially before the IDVR is placed in the system. In the economical point of view the initial charge of DC link should be calculated. By analyzing the real power using Energy Saving Injection method [6], the energy to which DC link energy should be charged initially can be calculated. Using energy saving injection method the sag factor can be computed in terms of the power factor of the load and independent of the power angle. This sag factor is utilized to compute the voltage to which the DC link capacitor has to be charged.

The real or active power essential for the DVR voltage sag mitigation is [7]:

$$P_{DVR} = S_{l1} \left[Pf_1 - \frac{Z}{3} \right] \quad (1)$$

where, $Z = \sqrt{X^2 + Y^2}$, $X = \sum_{j=1}^3 a_j \cos \delta_j$, $Y = \sum_{j=1}^3 a_j \sin \delta_j$, $\theta = \tan^{-1} \left(\frac{Y}{X} \right)$. The factor of voltage sag is $a_j = \frac{V_{bj}}{V_{lj}}$. δ_j is the angular phase difference between load voltage and source voltage.

$Z = 3 \times a$ is considered for a three phase network, 'a' is termed as sag factor. The power factor angle φ for a given β is

$$\beta = \varphi_2 - \left[\frac{[S_{l1}[Pf_1 - a] + P_{losses}]}{S_{l2}} + Pf_2 \right] \tag{2}$$

The sag factor can be written as:

$$a = \left[\frac{S_{l1}Pf_1 + P_{losses} - S_{l2}(1 - Pf_2)}{S_{l1}} \right] \tag{3}$$

For equal loading condition the losses are taken as 3%. Then 'a' is given as

$$a = [2 \times Pf_1 - 0.97] \tag{4}$$

From (4), the sag factor 'a' is influenced by the load 1 power factor Pf_1 connected to feeder 1. If the load power factor is given then the sag factor can be estimated. The sag factor indicates the maximum sag that can occur in the feeder, from which the compensated voltage can be determined. A controller is necessary for maintain the load voltage. In the following section control system of IDVR system is discussed

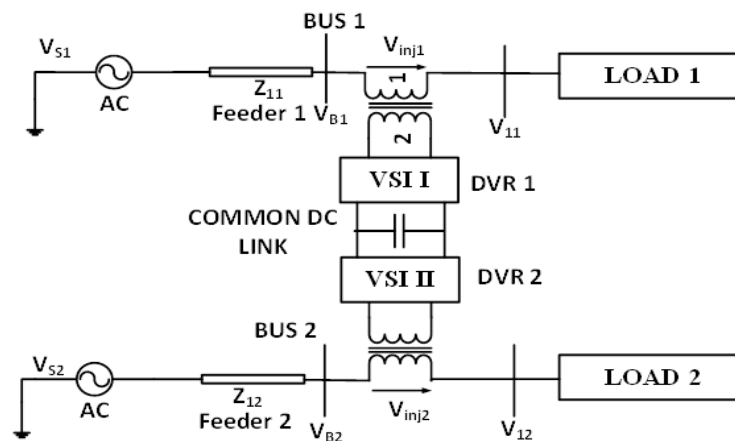

Figure 1. Schematic layout of Interline Dynamic Voltage Restorer

3. CONTROL SYSTEM OF IDVR FOR VOLTAGE SAG MITIGATION

The functionality of IDVR is to eliminate voltage sag in a system. Whenever there is a voltage sag, the IDVR detects the deviation in the voltage and injects the necessary voltage into the network thereby maintaining the system voltage constant at all conditions. The control system of IDVR plays an important role in controlling the injected voltage from IDVR. The schematic layout of the control system of IDVR is given Figure 2.

According to the schematic layout represented in Figure 2, the reference voltage $V_{ref(abc)}$ is converted to $V_{ref(dq)}$ axis using parks transformation given by.

$$\begin{bmatrix} V_{refd} \\ V_{refq} \\ V_{ref0} \end{bmatrix} = \frac{2}{3} \begin{bmatrix} \cos \theta & \cos(\theta - \frac{2\pi}{3}) & \cos(\theta + \frac{2\pi}{3}) \\ -\sin \theta & -\sin(\theta - \frac{2\pi}{3}) & -\sin(\theta + \frac{2\pi}{3}) \\ \frac{1}{2} & \frac{1}{2} & \frac{1}{2} \end{bmatrix} \begin{bmatrix} V_{refa} \\ V_{refb} \\ V_{refc} \end{bmatrix} \tag{5}$$

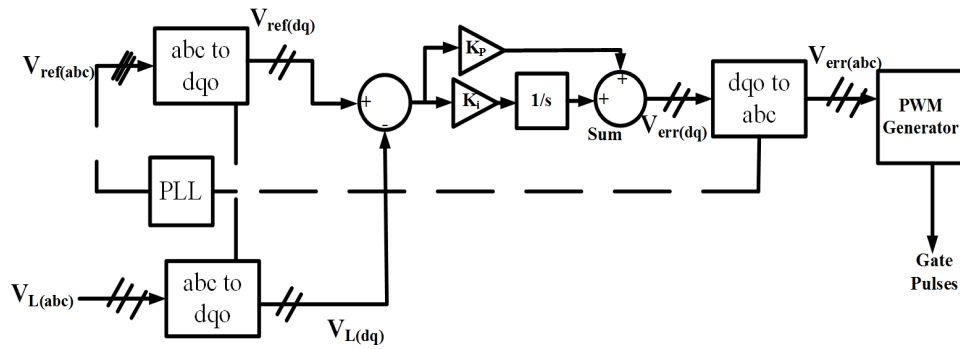

Figure 2. Schematic layout of control system of IDVR

Similarly $V_{L(abc)}$ is also converted to $V_{L(dq)}$. The error between the reference voltage and load or actual voltage is given is given as input to the Proportional Integral controller. The Proportional Integral controller regulates error and the output of the Proportional Integral controller is given by Equations (6) and (7)

$$V_{errd} = (K_p + \frac{K_i}{S})(V_{refd} - V_{Ld}) \tag{6}$$

$$V_{errq} = (V_{refq} - V_{Lq})(K_p + \frac{K_i}{S}) \tag{7}$$

where K_p and K_i are proportional integral gains of PI controller.

The $V_{err(dq)}$ is converted to $V_{err(abc)}$ by the dqo to abc transformation and $V_{err(abc)}$ is given to the PWM generator. The PWM generator generates the required gate pulses to the inverter. The values of K_p and K_i are determined by zigler- Nicholas method [15].

4. PHASE SHIFTING TRANSFORMERS

A Phase shifting Transformer (PST) controls the active power flow in a network by inserting the voltage with a controlled phase angle [16]. Figure 3 represents[16] the PST comprising of magnetizing transformer connected in parallel to the feeder and transformer which is connected in series to the feeder is boosting transformer. The phase shift is created by connecting these two transformers together there by controlling real power flow in the line. The secondary side of magnetizing transformer consists of a tap changer. By regulating the tap changer the real power will be regulated. The power angle Equation is:

$$P = \frac{V_1 \times V_2}{x} \sin \delta \tag{8}$$

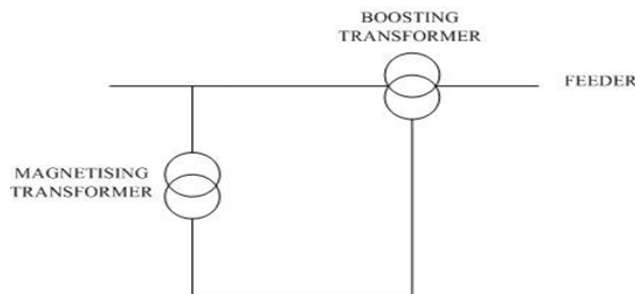

Figure 3. Schematic Layout of Phase Shifting Transformers

The operation of PST is illustrated by the phase diagram in the Figures 4(a) and 4(b). To shift the phase angle in one phase (say R phase), the input of the magnetizing transformer is connected to the other two phases (Y and B phases). V_{YB} is the resultant voltage in the phasor diagram which is fed to the primary winding of the boosting transformer. Observing the phasor diagram in Figure 4(a), that voltages V_{YB} and V_{RN} have phase difference of 90° . The resultant voltage between V_{YB} and V_{RN} will be the output of the boosting transformer. Depending on the magnitude of voltage vector V_{YB} , the resultant voltage phase and magnitude can be determined. According to the power Equation in (8), the active power will be increased with the increment in the phase difference between the resultant voltage and load voltage shown in Figure 4(b).

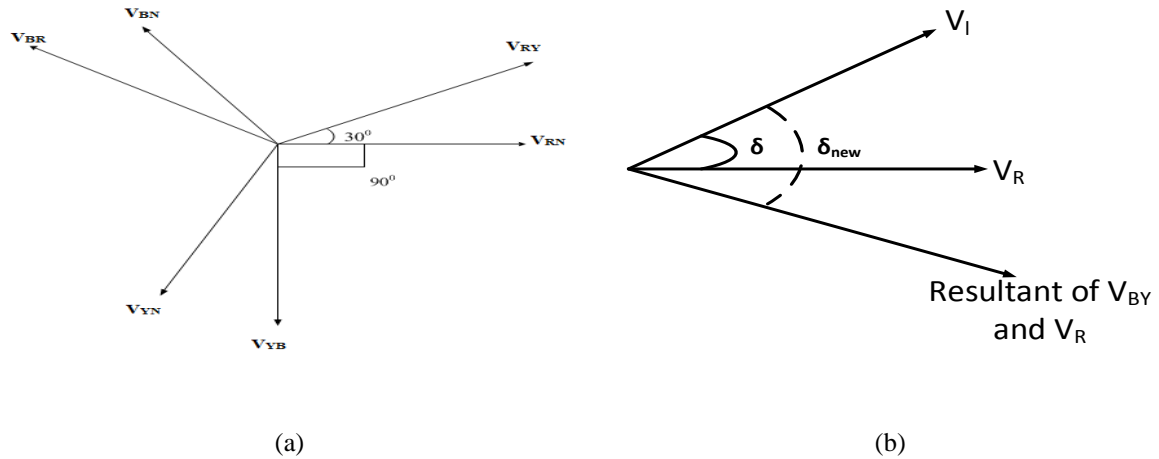

Figure 4. (a) Phasor Diagram of Voltages in healthy feeder with PST (b) resultant phasor diagram of healthy feeder

5. SIMULATION RESULTS AND DISCUSSION

The test power system is constructed using MATLAB SIMULINK software is represented in Figure 5(a). The two feeders each are having three phases connected to three different single phase loads i.e. the total load on one feeder is unbalanced load. Consider the case where one of the loads (Load 1 in this case) connected to the three phases of a feeder is sensitive, then this load clearly requires a protection from power quality issues mainly voltage sag. Hence IDVR is connected to that particular phase to ensure that the sensitive load is protected from the voltage sag. Loads 1 and 4 which are connected to feeder 1 and 2 are assumed as sensitive loads. The considered test power system parameters is represented in Figure 5(a) are shown in Table 1.

Table 1. Parameters of two line IDVR

Parameter	Feeder 1	Feeder 2
Supply Voltage	230V	230V
Load Voltage	230V	230V
Load Resistance	40Ω	40Ω
Load Inductance	95.5mH	95.5mH
Transformer Resistance	3Ω	3Ω
Transformer Inductance	10mH	10mH
DC Capacitance	3200μF	
DC Voltage	210V	

The PST (rating of both transformers is 600VA, 50 Hz and turns ratio of magnetizing transformer is 2:1 and that of boosting transformer is 1:1) is provided to restore the DC link energy. The controller of the DC Link is represented in Figure 5(a) is a controller which compares the reference DC link and actual DC link voltage during the voltage sag condition and based on voltage sag condition the controller chooses the suitable feeder to which the PST has to be connected for restoration of DC link energy. Hence the DC link voltage is maintained constant. The control algorithm of DC link controller is shown in Figure 5(b).

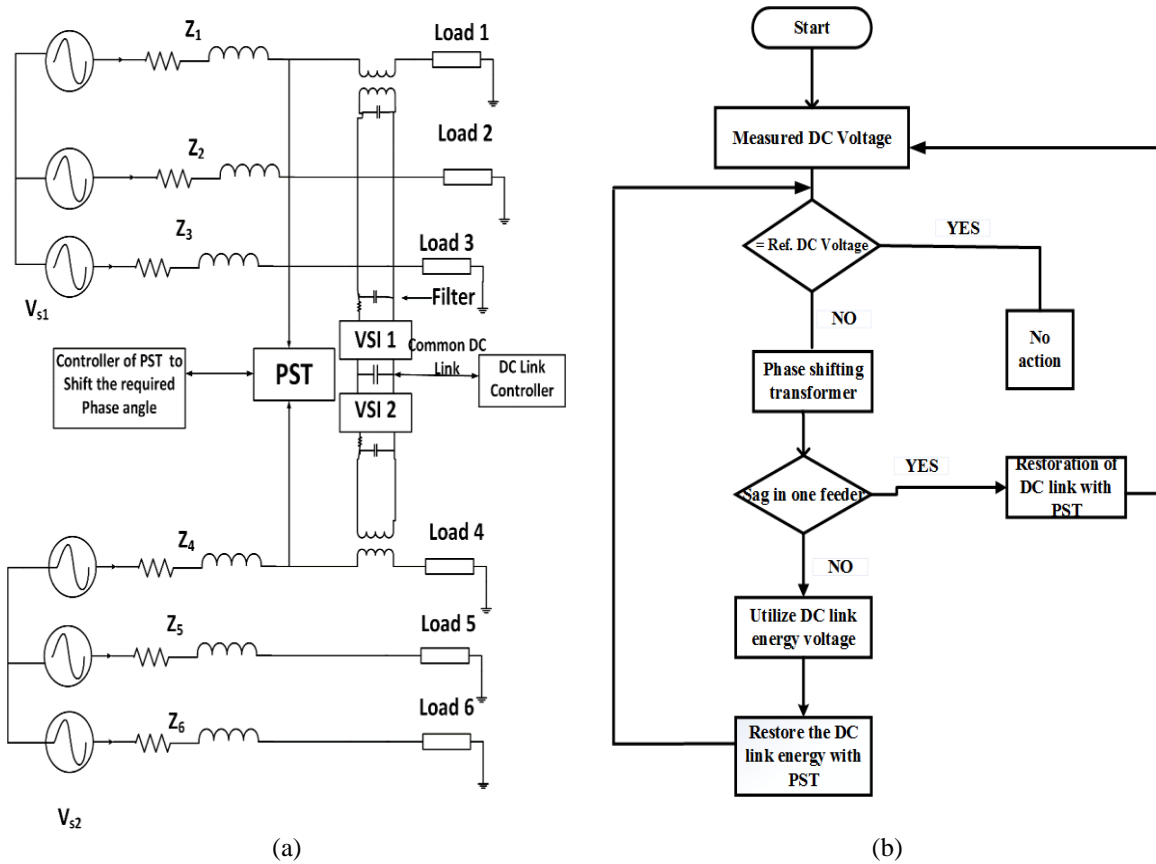

Figure 5. (a) Simulink model of IDVR (b) Control algorithm of DC link controller

5. 1. Voltage Sag Applied in First Feeder and Restoring the DC link Energy with PST

Feeder 1 shown in Figure 5(a) is assumed to be effected with a voltage sag for a period of time. Feeder 2 is considered to be unaffected. The control unit then associates the PST to the second feeder. The angular phase of the feeder 2 is shifted by Phase Shifting Transformer. The real power flow in the feeder 2 increases due to the phase shift. The incremental active power will be utilized for DC link restoration by second DVR present on the second feeder. The Proportional Integral controller present in the second DVR keeps the voltage of the load on second feeder to the rated value. Load voltage of feeder 1 during the voltage sag condition with the absence and presence of IDVR and voltage at the DC link with PST are represented in Figure 6(a) and Figures 6(b), (c) respectively. A reduction in load voltage due to the voltage sag is observed in Figure 6(a). In the presence of IDVR the voltage sag is eliminated which is observed in Figure 6(b). The load voltage of feeder 2 to which PST are connected is represented in Figure 6(d). It is observed that while restoring the DC link energy, the feeder 2 load voltage is also maintained constant by the PI controller of the control system in second DVR.

In the literature [17], PST is uncontrolled which means that the phase shift produced by PST is default one value (depends on the turns ratio of the magnetizing and boosting transformers) irrespective of the power that should be compensated. Hence in this paper a control action is developed which calculates the required power needed for the compensation. From that phase shift is calculated using the Equations given in [16]. When the angle is known according, the turns ratio of boosting transformer is adjusted there by the

output of PST will give calculated phase shift. The drawback of using PST for replenishing the DC link energy is; the maximum phase angle shift between source and load voltage can be 90° . At this instant power is maximum and beyond which the power cannot be increased. Hence PST is used for limited to certain limits of the compensation.

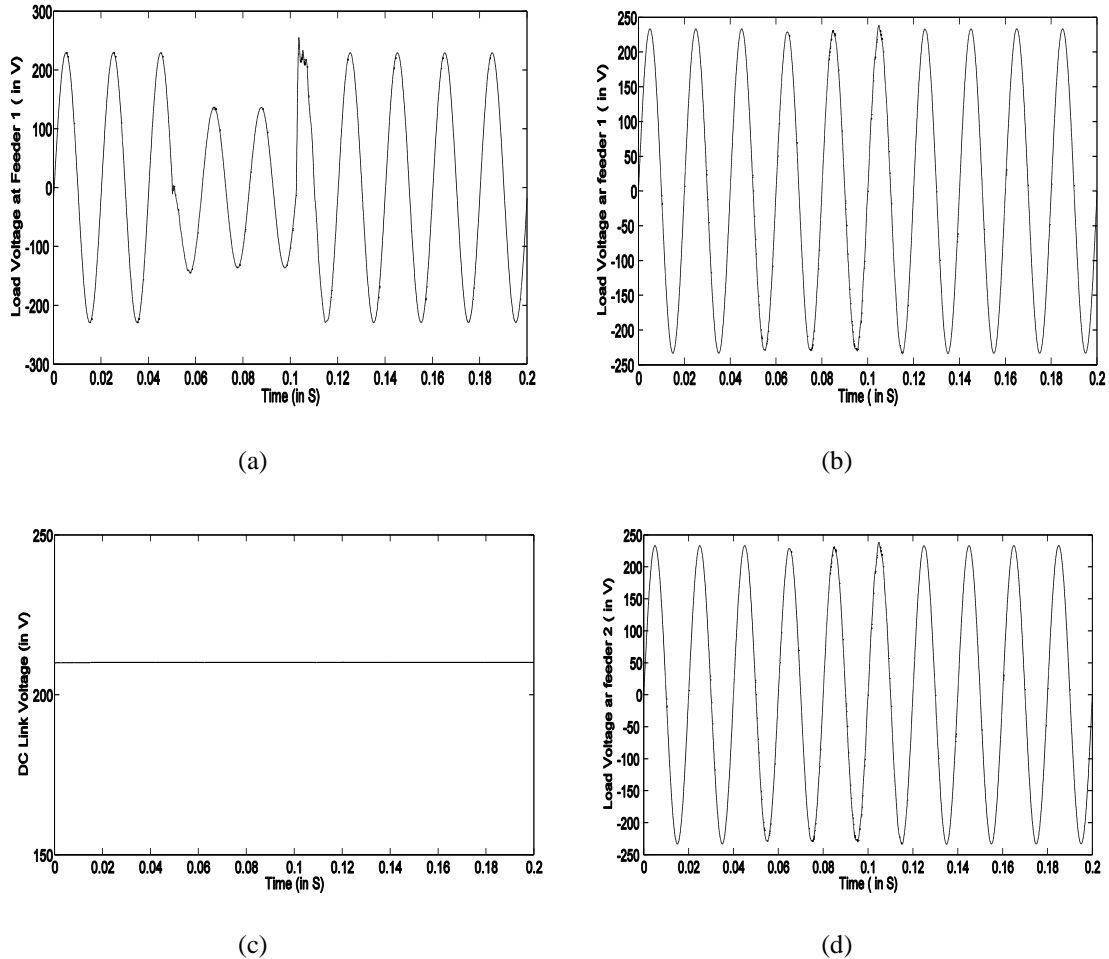

Figure 6. (a) Load voltage at feeder 1 (in Volts) without IDVR, (b) Load voltage in feeder 1 (in Volts), (c) DC link voltage (in volts) with IDVR and Phase Shifting Transformer, (d) Load voltage at feeder 2 (in Volts)

5.2. Voltage sag Applied in Two Feeders in the Absence of PST for Restoration

If both feeders are simultaneously effected with voltage sag, then PST cannot be utilized in this as it can only be associated with a healthy feeder. Hence, the initial charged energy of the DC link is used for mitigating the voltage sag in both feeders. Figure 7(a) shows the voltage sag in feeders 1 and 2 respectively. When IDVR is placed the voltage sag is compensated as shown Figure 7(b). Since the IDVR is compensating the voltage sags through the charged energy of DC link there is decline in the DC link voltage as seen Figure 7(c). When the mitigation process is completed the controller at the DC link will compensate the DC link with PST depending on the condition prevailed.

Hence in both conditions the IDVR could effectively mitigate the voltage sag and protected the sensitive loads from getting damaged by the affect the voltage sag. From the obtained simulation results it can be concluded that PST restoration of DC link for IDVR is comparitvely appropriative than the other methods of DC link restoration for IDVR [7], [12], [13]. In previous complex methods of DC link restoration, one of feeders to which the IDVR is connected is always to be assumed as healthy feeder. On the other hand, utilizing PST is simpler way to restore the DC link energy for IDVR and also PST can be connected to any of the feeders to which the IDVR is connected.

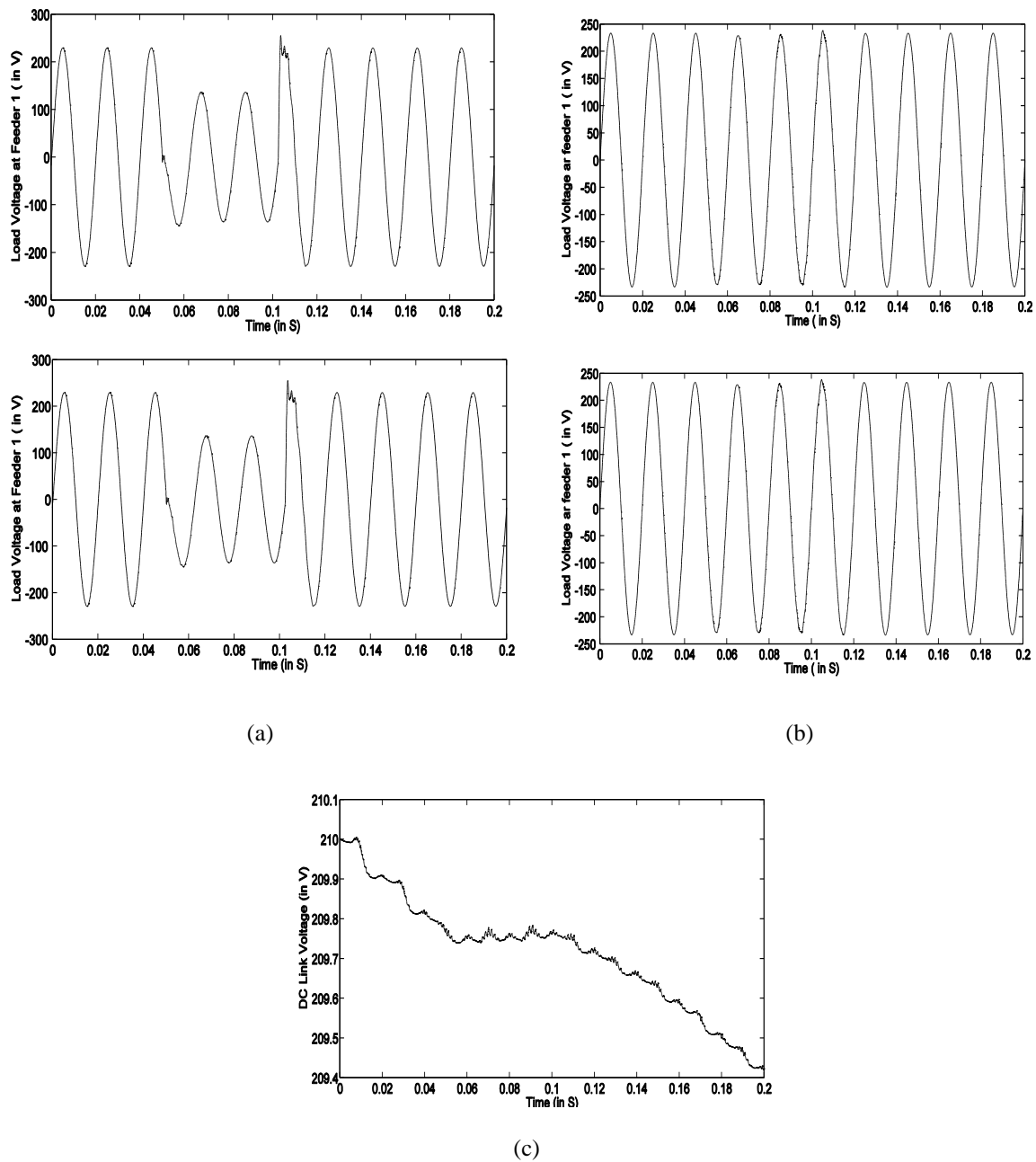

Figure 7. (a) Load voltage in feeder 1 and in feeder 2(in Volts) without IDVR, (b) Load voltage in feeder 1 and feeder 2(in Volts) with IDVR, (c) DC link voltage (in volts) without PV system and PST

6. CONCLUSION

The present research focuses on the issues related to power quality faced at the distribution side. The most important power quality problem considered in this paper is voltage sag. IDVR will be the suitable device for compensation of voltage sag in multiple feeder lines. The control system of IDVR identifies the voltage error between the actual and reference voltages and accordingly sets the Pulse Width Modulation generator to generate the inverter gate pulses for the voltage injection and thus compensating the voltage sag. A novel way of replenishing the DC link energy of IDVR is proposed in this paper. PST is utilized for the DC link restoration. Based on the sag condition the suitable feeder to which the PST is to be connected for the restoration of DC link energy is selected through a proposed controlling algorithm. Additionally a phase shift produced by PST is controlled according to the required power for the compensation.

REFERENCES

- [1] G. J. S. Dhas and T. R. D. Prakash, "A Novel Approach for Voltage sag Mitigation using FACTS device interline dynamic voltage restorer," ICECT 2011 - 2011 3rd Int. Conf. Electron. Comput. Technol., vol. 4, pp. 37–41, 2011.
- [2] V. K. Mehta and R. Mehta, Principles of Power System: Including Generation, Transmission, Distribution, Switchgear and Protection : for B.E/B.Tech., AMIE and Other Engineering Examinations. S. Chand, 2005.
- [3] S. M. Mahaei, M. T. Hagh, and K. Zare, "Modeling FACTS Devices in Power System State Estimation," *International Journal of Electrical and Computer Engineering*, vol. 2, no. 1, pp. 57–67, 2012.
- [4] A. Ghosh and G. Ledwich, "Compensation of Distribution System Voltage using DVR," *IEEE Trans. Power Deliv.*, vol. 17, no. 4, pp. 1030–1036, Oct. 2002.
- [5] H. Marefatjou, M. Sarvi, "Compensation of Single-Phase and Three-Phase Voltage Sag and Swell Using Dynamic Voltage Restorer," *International Journal of Electrical and Computer Engineering*, vol. 1, no. 3, pp. 129–144, 2012.
- [6] S. S. Choi, B. H. Li, D. M. Vilathgamuwa, "Dynamic Voltage Restoration with Minimum Energy Injection," *IEEE Trans. Power Syst.*, vol. 15, no. 1, pp. 51–57, 2000.
- [7] D. M. Vilathgamuwa, H. M. Wijekoon, S. S. Choi, "Interline Dynamic Voltage Restorer: A Novel and Economical Approach for Multiline Power Quality Compensation," *IEEE Trans. Ind. Appl.*, vol. 40, no. 6, pp. 1678–1685, 2004.
- [8] H. M. Wijekoon, D. M. Vilathgamuwa, and S. S. Choi, "Interline Dynamic Voltage Restorer: An Economical way to Improve Interline Power Quality," *IEE Proc. - Gener. Transm. Distrib.*, vol. 150, no. 5, p. 513, 2003.
- [9] A. Elserougi, A. Hossam-Eldin, A. Massoud, S. Ahmed, "Investigation of Inter-Line Dynamic Voltage Restorer with Virtual Impedance Injection," IECON Proc. (Industrial Electron. Conf.), pp. 1975–1980, 2010.
- [10] A. Elserougi, A. M. Massoud, A. S. Abdel-Khalik, S. Ahmed, A. A. Hossam-Eldin, "An Interline Dynamic Voltage Restoring and Displacement Factor Controlling Device (IVDFC)," *Power Electron. IEEE Trans.*, vol. 29, no. 6, pp. 2737–2749, 2014.
- [11] C. N. Ho, H. S. H. Chung, K. T. K. Au, "Design and Implementation of a Fast Dynamic Control Scheme for Capacitor-Supported Dynamic Voltage Restorers," *IEEE Trans. Power Electron.*, vol. 23, no. 1, pp. 237–251, Jan. 2008.
- [12] P. U. Rani, "Modeling and Simulation of Interline Dynamic Voltage Restorer using SVPWM Technique," vol. 60, no. 1, 2014.
- [13] P. V. Naidu, "Design of a Hysteresis Voltage Control Based Interline DVR (IDVR) with VA Optimization," 2014.
- [14] M. Shahabadini and H. Iman-Eini, "Improving the Performance of Cascaded H-Bridge Based Interline Dynamic Voltage Restorer," *IEEE Trans. Power Deliv.*, vol. 8977, no. c, pp. 1–1, 2015.
- [15] B. W. Bequette, Process Control: Modeling, Design, and Simulation, Prentice Hall Professional, 2003.
- [16] J. Winders, Power Transformers: Principles and Applications, CRC Press, 2002.
- [17] R. Nittala, A. M. Parimi, and K. U. Rao, "Phase Shifting Transformer based Interline Dynamic Voltage Restorer to Mitigate Voltage sag," in 2013 Annual IEEE India Conference, INDICON, 2013.