

Maximum Power Point Tracking using Particle Swarm Optimization Algorithm for Hybrid Wind-Tidal Harvesting System on the South Coast of Java

Fransisco Danang Wijaya, Kuku Daud Pribadi, Sarjiya

Department of Electrical Engineering and Information Technology, Universitas Gadjah Mada, Yogyakarta, Indonesia

Article Info

Article history:

Received Oct 24, 2016

Revised Jan 23, 2017

Accepted Feb 7, 2017

Keyword:

MPPT

Ocean energy

PSO

Renewable energy

Wind energy

ABSTRACT

This paper proposes a hybrid wind-tidal harvesting system (HWTHS). To extract maximum power from the wind and tidal, HWTHS implements particle swarm optimization (PSO) algorithm in maximum power point tracking (MPPT) method. The proposed HWTHS had been tested on the range of possible input appropriate to the characteristics of the southern coast of Java. The presented result shows that by using PSO-based MPPT algorithm, maximum power point can be achieved. Thus the efficiency of HWTHS is 92 %, 94 % in wind section and 91 % in tidal section. By using PSO-based MPPT, HWTHS can respond well to changes in wind and tidal speed, whether it's a change from low speed to a higher speed or change from high speed to lower speed wherein time to reach new steady state is ± 0.1 s. At varied wind and tidal speed, PSO algorithm can maintain C_p of the system in the range of 0.47 - 0.48 so that power can be extracted to the maximum.

Copyright © 2017 Institute of Advanced Engineering and Science.
All rights reserved.

Corresponding Author:

Kuku Daud Pribadi,

Department of Electrical Engineering and Information Technology,

Universitas Gadjah Mada,

Grafika No 2, Yogyakarta 55281, Indonesia.

Email: teknik@ugm.ac.id

1. INTRODUCTION

Indonesia is an archipelago that 2/3 of its territory is ocean. It has the longest coastline in the world, about ± 80791.42 km, which is a potential area for development of wind and ocean power plants. Indonesia has average wind speed about ± 5 m/s. The wind speed of 4 m/s to 5 m/s is classified as low-sized with a potential capacity of 1-100 kW. Moreover, the extent of marine areas of Indonesia is also a potential source of ocean wave energy. Several marine areas in Indonesia have an average wave height between 0.5 to 3 m.

To optimize the power generation systems, two or more types of energy sources can be combined. Each of the energy sources can overcome the weakness of the other. The intermittent nature of wind energy can be compensated by the predictable nature of ocean wave energy. However, the existence of maximum power point tracker in renewable energy power plants are still essential to ensure that the maximum power can be extracted [1], [2]. On [3], a step size which is used is a fixed value so that it will affect the speed of achieving convergent. Choosing the appropriate value of a step size is essential in designing MPPT. A small step size values will minimize the occurrence of oscillations but the system will take a long time to achieve convergent. Large step size values will shorten the time to achieve convergent but oscillation will occur around the optimum point so it will produce losses. Thus, the use of adaptive step-size MPPT algorithm is the right solution to optimize speed to achieve convergent and losses due to oscillations [4-6]. Research surrounding adaptive MPPT is getting a lot done, some algorithms which have been used are neuro-fuzzy, genetic algorithms, simulated annealing, and PSO. The use of adaptive MPPT algorithm shows a good

performance to maximize the output power of renewable energy power plants. By using PSO algorithm, efficiency of wind energy conversion systems can be increased, and showed a good performance in responding to changes in wind speed, as presented in [7].

In this research, hybrid wind-tidal harvesting system (HWTHS) was composed of wind and tidal turbine system. To maximize the output power of HWTHS, PSO algorithm was used to control the duty cycle of the buck-boost converter. MPPT process was performed on each system, wind energy system (WES) and tidal energy system (TES), so that the maximum power of each system can certainly be extracted. Furthermore, total extracted power from the two systems were transferred to the load. In this study, HWTHS was tested in accordance with the prevailing winds and ocean waves on the south coast of Java island.

2. HWTHS's MPPT

HWTHS was composed of wind turbine, tidal turbine, rectifier, buck-boost converter, and load as shown in Figure 1. Wind and tidal turbine was used to convert wind and tidal energy into mechanical energy according to (1). The coefficient of performance of the turbine (C_p) represents the power extraction efficiency from turbines. In theory, the maximum value of C_p is 0.59, but in practice the C_p values only in the range of 0.4 – 0.45 [8]. At each turbine there is a specific operating point where the mechanical power can be extracted to the maximum, the point is commonly referred to optimum tip speed ratio (TSR). TSR (λ) is the ratio between the rotational speed to wind (or tidal) speed (4). In the state of wind and tidal vary over the time, the TSR should be maintained so the value will always be at the optimum point. Thus, the C_p of the system can be kept constant at the optimal point so that maximum electrical power can be extracted.

$$P_m = \frac{1}{2} \rho \pi R^2 V^3 C_p(\lambda, \beta), \quad (1)$$

$$C_p(\lambda, \beta) = \frac{1}{2} \left(\frac{161}{\lambda_i} - 0.48\beta - 5 \right) e^{-\frac{21}{\lambda_i}}, \quad (2)$$

$$\frac{1}{\lambda_i} = \frac{1}{\lambda + 0.08\beta} - \frac{0.035}{1 + \beta^3}, \quad (3)$$

$$\lambda = \frac{\omega_m R}{V}. \quad (4)$$

where P_m is mechanical power, ρ is air and seawater density, R is rotor diameter, V is wind or tidal speed (m/s), β is pitch angle, and ω_m is rotational speed. Figure 2 shows the power characteristics of wind and tidal turbine in which at any wind and tidal speed there is a certain rotational speed where the maximum power generated. The point becomes the target of MPPT so C_p can be kept constant at the optimal point and the generated power is always maximum.

To be able to extract the maximum power, duty cycle of the buck-boost converter was equipped with MPPT algorithm. The output power of the buck-boost converter was the basis variable for evaluating the duty cycle. In this study, the PSO algorithm used 3 particles wherein the particles represent a duty cycle (d). While speed (Φ) represents step-size of duty cycle. MPPT process was carried out with reference to Figure 3. Where w is the momentum factor ($w = 0.15$), r_1 and r_2 are random values between 0 and 1, c_1 and c_2 are acceleration constants ($c_1 = c_2 = 0.5$ and 1.6).

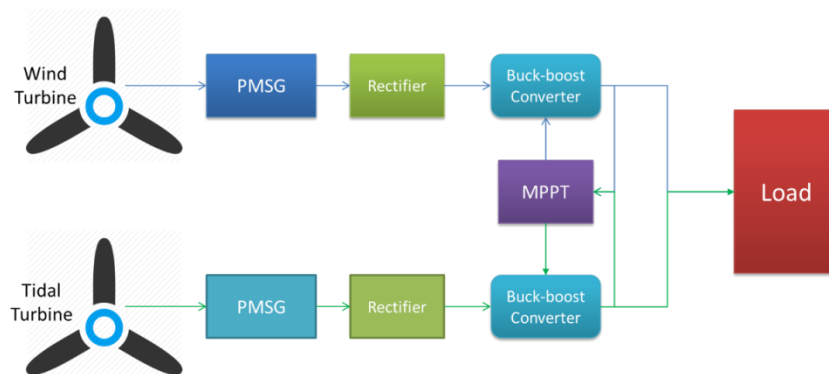

Figure 1. Block diagram of HWTHS

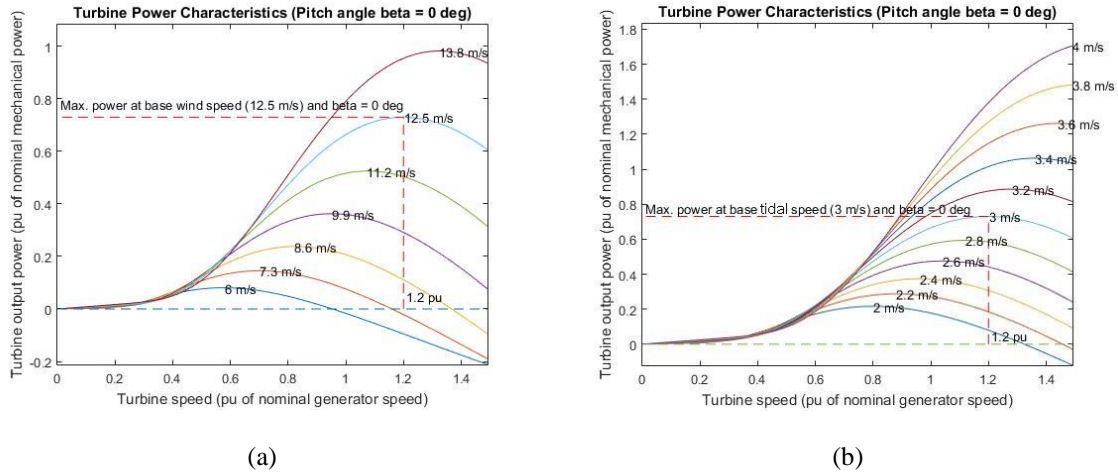

Figure 2. (a) Characteristics of turbine power as a function of the rotor speed for a series of wind speeds, (b) Characteristics of turbine power as a function of the rotor speed for a series of tidal speeds

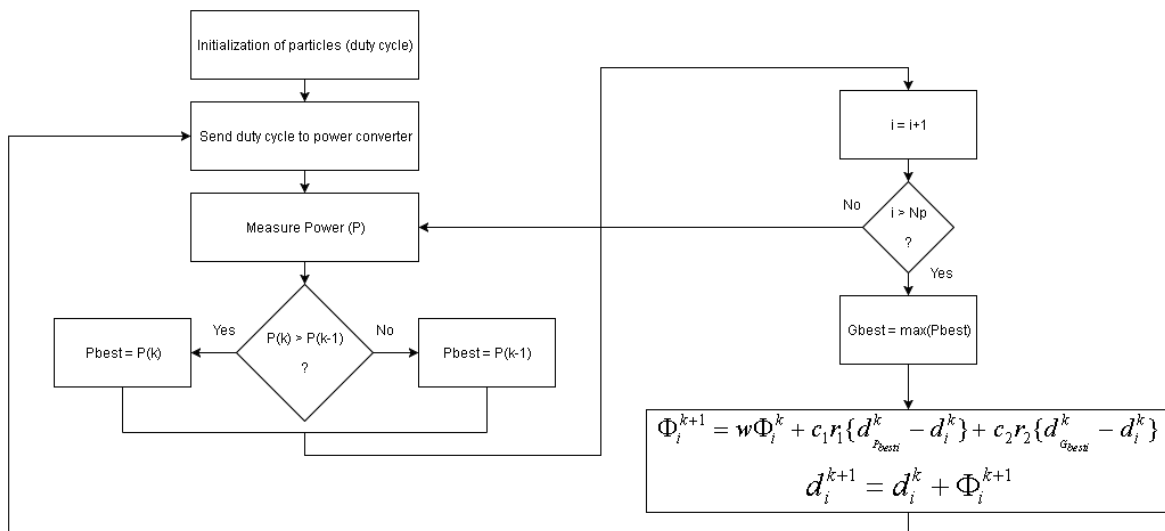

Figure 3. Flowchart of PSO MPPT algorithm

Wind and tidal turbine parameters used in this research can be seen in Table 1 along with parameters of PMSG. Figure 4 shows wind and sea waves characteristic which were the basis for testing the proposed system.

The wind gradient in the region of Indonesia generally blows from the southeast - Southwestern with wind speeds ranging between 2.5 - 10 m/s. With the highest wind speeds were in the Western Indian Ocean South Sumatra to East Java, Andaman Sea, South China Sea, Java Sea and the Eastern Pacific Ocean Philippines. Figure 4 (a) is a sample data of wind speed on the South Coast of Java taken from 2 - 5 September 2016. The wind speed varied between 1.03 - 5.66 m/s with an average wind speed of 3.81 m/s. At that time the dominant wind speed was 4-5 m/s. This was influenced by the character of the monsoon east where the wind blew from the continent of Australia to the Asian continent through the desert in the northern part of Australia and only through the narrow sea. So the wind was dry which resulting territory of Indonesia suffered drought and in general had a relatively stable wind speed.

When the wind blows over the surface of the sea, some of its energy is transferred to the sea water through friction between the air molecules and the water molecules. Data showed that several marine areas in Indonesia had the potential waves with an average height of 0.5 – 2 m, which is a potential source of energy to generate electricity. Sample data of ocean wave height on the South Coast of Java can be seen in

Figure 4(b). Ocean Wave height varied between 2.4 – 2.8 m with an average height of 2.54 m. Although the process of formation of waves influenced by the wind, but both have different characteristics. As can be seen on Figure 4(b), ocean wave is more predictable and stable, so the nature of ocean wave energy can be used to compensate the intermittent nature of wind energy.

Table 1. The Parameter of Wind and Tidal Turbine

Wind Turbine – PMSG		Tidal Turbine - PMSG	
Rated wind speed	14 m/s	Rated tidal speed	3 m/s
Rotor diameter	0.9 m	Rotor diameter	0.9 m
Rated power	1 kW	Rated power	1.5 kW
Inertia	0.0008 kg.m ²	Inertia	0.0004 kg.m ²
Nominal rotational speed	1.2 pu	Nominal rotational speed	1.2 pu
Stator phase resistance	8.67 mΩ	Stator phase resistance	8.67 mΩ
d-axis inductance	2.86 mH	d-axis inductance	2.86 mH
q-axis inductance	3.44 mH	q-axis inductance	3.44 mH
Rotational damping	0.001 N.m.s	Rotational damping	0.001 N.m.s

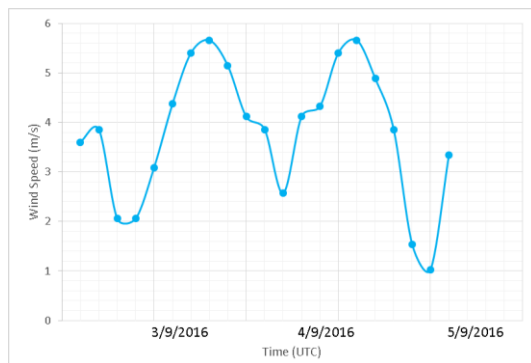

(a)

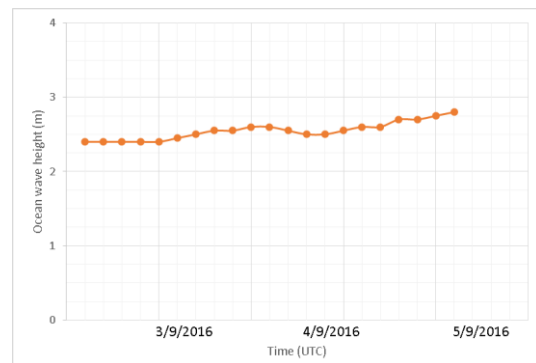

(b)

Figure 4. (a) Wind characteristic on the south coast of Java, (b) Ocean wave characteristic on the south coast of Java

3. RESULTS AND ANALYSIS

After the analysis of the design and MPPT mechanism for HWTES, simulation using Simulink was conducted to verify the proposed method as shown in Figure 5. In this simulation, the parameters used in HWTES refer to Table 1. The load used in this study is a resistive load with a value 10 Ω.

3.1. Performance of PSO MPPT Algorithm for Each System

Based on simulation results, the greater the wind speed, the output power of the WES became greater. This also applies to TES, the greater the speed of the tidal, the output power of TES also increased. PSO algorithm which was implemented on HWTES could increase the output power of each system, both WES and TES. Thus, the efficiency of WES could be increased from 71% to 94% while TES's efficiency increased from 66% to 91%. In the TES, in addition to improve the efficiency of 24%, the use of the PSO algorithm also could maintain system efficiency at 91% where TES's efficiency that did not use MPPT varies between 49-86%. Performance of WES and TES at any wind speed and tidal speed can be seen in Figure 6.

3.2. Performance of PSO MPPT Algorithm for HWTES

Based on [9], tidal speed is a function of the ocean wave height as stated in (5). Where U is tidal speed, m was average beach slope ($m= 0.033$), g is acceleration of gravity ($g= 9.8 \text{ m/s}^2$), H is ocean wave height, and α was the wave breaker angle ($\alpha= 15^\circ$).

$$U = 20.7m\sqrt{gH}\sin 2\alpha \quad (5)$$

Thus, based on Figure 4(b), tidal speed on the south coast of Java was in the range of 1.5 - 1.8 m/s. Figure 7(a) and Figure 8(a) shows a model of wind speed and tidal speed used for HWTHS testing.

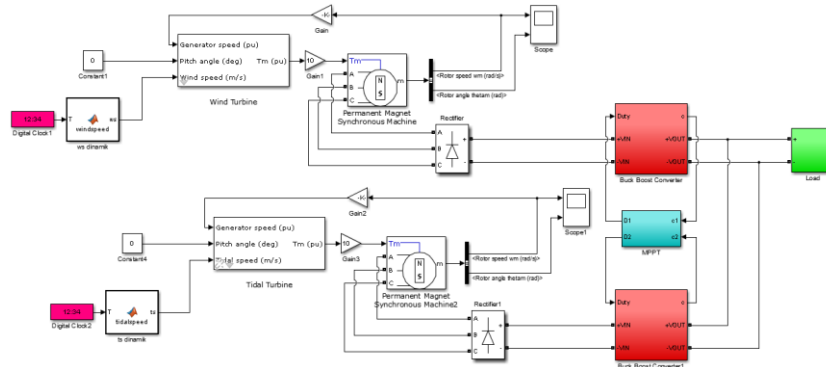

Figure 5. Simulink block of HWTHS

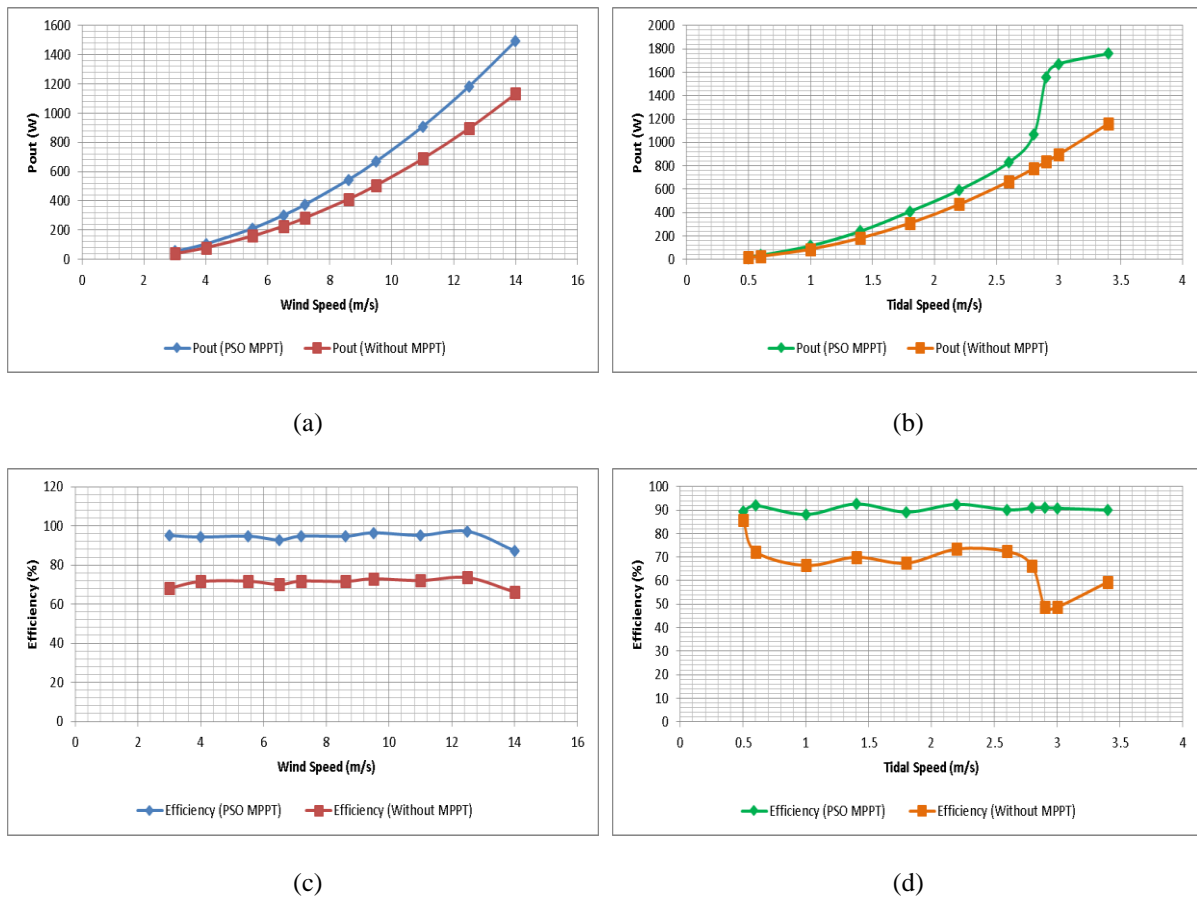

Figure 6. (a) Output power of stand-alone wind energy system, (b) Output power of stand-alone tidal energy system, (c) Efficiency of stand-alone wind energy system, (d) Efficiency of stand-alone wind energy system

During 3 s, wind speed changed from 5 m/s to 6 m/s then down to 4 m/s. Generator rotation speed responded well to wind speed changes wherein time to reached new steady state was 0.1 s. When the wind speed varied from 4 m/s to 6 m/s, power that could be extracted varied from 105 W to 260 W and C_p was in the range of 0.47 – 0.48. C_p 's response, generator rotation speed, and WES's extracted power can be seen Figure 7. As for the TES, tidal speed rose from 1.7 m/s to 1.8 m/s then down to 1.5 m/s. As in WES, TES's

generator rotation speed responded well to change in tidal speed wherein time to reach new steady state was 0.05 s. When the tidal speed was in the range of 1.5 – 1.8 m/s, power that could be extracted varied between 280 W and 409 W, also C_p was in the range of 0.47 – 0.475. C_p 's response, generator rotation speed, and TES's extracted power can be seen Figure 8.

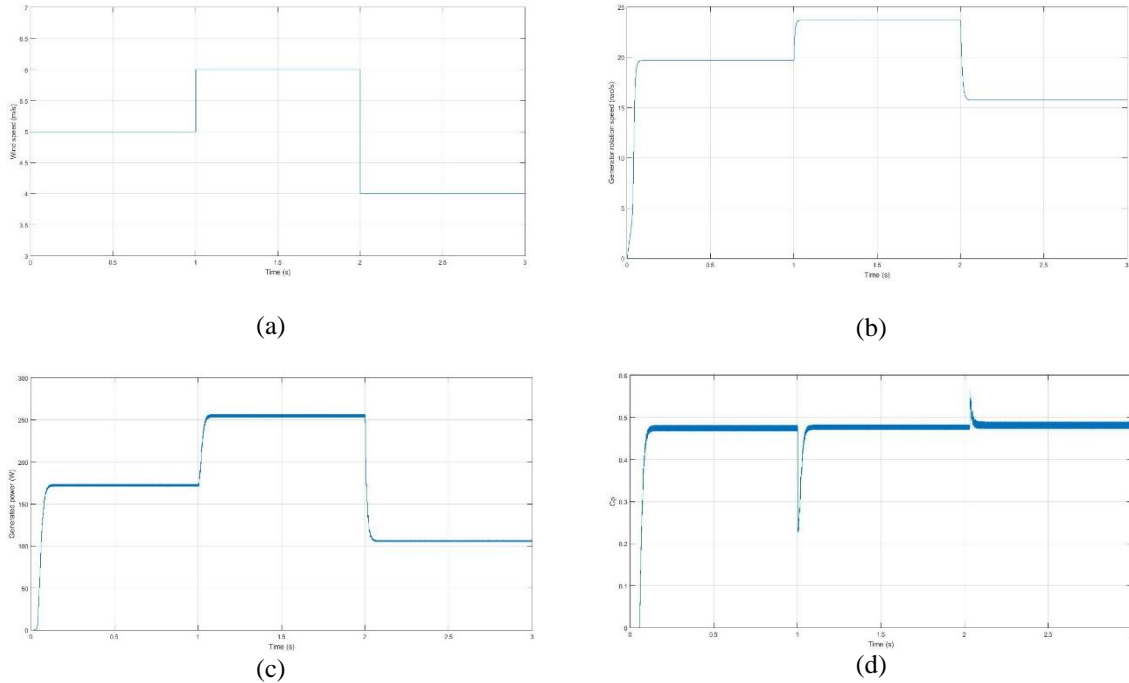

Figure 7. (a) Wind speed, (b) Wind generator rotation speed, (c) Wind extracted power, (d) WES power coefficient

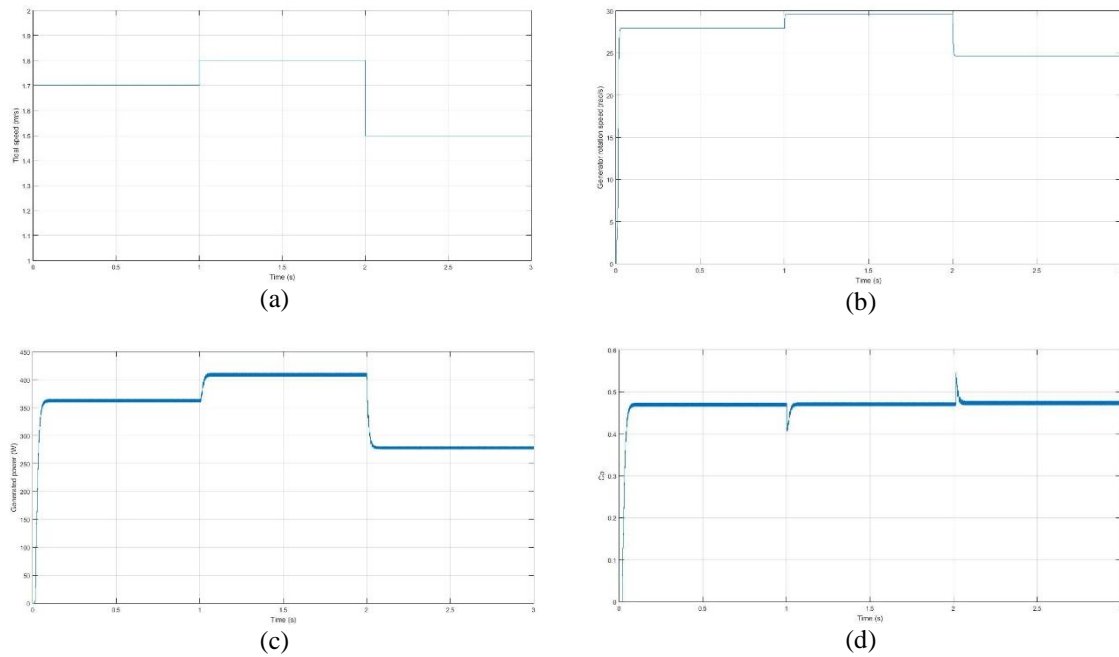

Figure 8. (a) Tidal speed, (b) Tidal generator rotation speed, (c) Tidal extracted power, (d) TES power coefficient

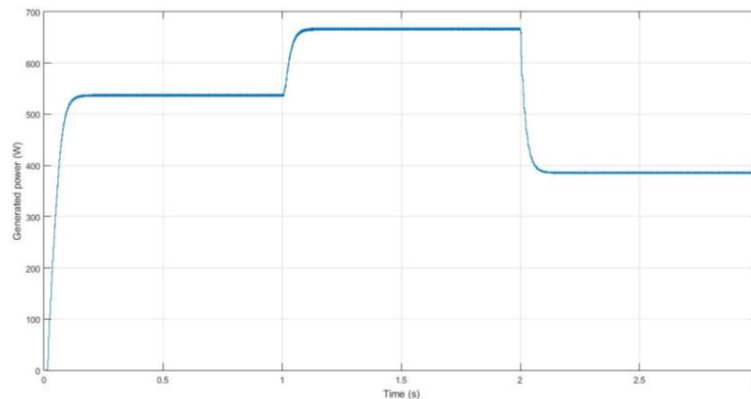

Figure 9. Total harvested power from HWTHS

Figure 9 shows harvested power from HWTHS at wind speed 4 – 6 m/s and tidal speed 1.5 – 1.8 m/s. At a wind speed of 4 m/s and tidal speed of 1.5 m/s, the power of 385 W was harvested while at wind speed of 6 m/s and tidal speed of 1.8 m/s, the power harvested at 669 W. Thus, the maximum power of each system had been successfully extracted at each corresponding input conditions.

4. CONCLUSION

The proposed HWTHS was composed of wind turbine, tidal turbine, rectifier, buck-boost converter, and load. MPPT process was performed on each system, WES and TES. The proposed system had been tested on the range of possible input appropriate to the characteristics of the southern coast of Java. The presented result shows that by using PSO-based MPPT algorithm, maximum power point can be achieved. Thus the efficiency of HWTHS is 92 %, 94 % in wind section and 91 % in tidal section. By using PSO-based MPPT, HWTHS can respond well to changes in wind and tidal speed, whether it's a change from low speed to a higher speed or change from high speed to lower speed wherein time to reach new steady state is ± 0.1 s. At varied wind and tidal speed, PSO algorithm can maintain C_p of the system in the range of 0.47 - 0.48 so that power can be extracted to the maximum.

ACKNOWLEDGEMENTS

The authors would like to thank Faculty of Engineering Universitas Gadjah Mada for providing the facilities to conduct this research.

REFERENCES

- [1] L.H. Pratomy, F.D. Wijaya e E. Firmansyah, "Capacitor Bank Voltage Equilibrium for MPPT in Single-Phase Single-Stage Five-Level Inverter for PV-Grid", *International Journal of Electrical and Computer Engineering*, pp. 62-71, 2015.
- [2] K.T. Ahmed, M. Datta e N. Mohammad, "A Novel Two Switch Non-inverting Buck-Boost Converter Based Maximum Power Point Tracking System", *International Journal of Electrical and Computer Engineering*, vol. 3, pp. 467-477, 2013.
- [3] Y. Da e A. Khaligh, "Hybrid Offshore Wind and Tidal Turbine Energy Harvesting System with Independently Controlled Rectifiers", em *IECON '09. 35th Annual Conference of IEEE*, 2009.
- [4] M.K. Hong e H.H. Lee, "Adaptive Maximum Power Point Tracking Algorithm for Variable Speed Wind Power Systems", *Life System Modeling and Intelligent Computing*, vol. 6328, pp. 380-388, 2010.
- [5] S.M.R. Kazmi, "A Novel Algorithm for Fast and Efficient Speed-Sensorless Maximum Power Point Tracking in Wind Energy Conversion Systems", *IEEE Transactions on Industrial Electronics*, vol. 58, pp. 29-36, 2011.
- [6] E.A. Amon, T.K.A. Brekken e A.A. Schacher, "Maximum Power Point Tracking for Ocean Wave Energy Conversion", *IEEE Transactions On Industry Applications*, vol. 9, pp. 1079-1086, 2012.
- [7] K. Daud, F.D. Wijaya e Sarjiya, "Dynamic Response Of Maximum Power Point Tracking Using Particle Swarm Optimization For Wind Energy Conversion System", em *International Conference on Information Technology And Electrical Engineering*, Yogyakarta, 2016.
- [8] J.M.G. a. F.B. Zhe Chen, "A Review of the State of the Art of Power Electronics," p. 17, 2009.
- [9] R.M. Sorensen, *Basic Coastal Engineering*, Pennsylvania: Springer Science+Business Media, Inc., 2006.

BIOGRAPHIES OF AUTHORS

Fransisco Danang Wijaya was born on February 1974 in Sleman, Indonesia. He received his Bachelor and Master degree, both from Electrical Engineering Major, Gadjah Mada University in 1997 and 2001 respectively. He then got his Doctor of Engineering in Tokyo Institute of Technology in 2009. He is currently Associate Professor at the Department of Electrical Engineering and Information Technology, Gadjah Mada University. His research is specialized in power system engineering, energy conversion, also transmission and distribution system. He is also expert in power system control technique using Magnetic Energy Recovery Switch (MERS).



Kukuh Daud Pribadi was born on February 1995 in Bekasi, Indonesia. He received his Bachelor degree of Electrical Engineering from Department of Electrical Engineering and Information Technology, Gadjah Mada University in 2016. His research interests include maximum power point tracking, optimization, power systems, and renewable energy. He is currently conducting research about optimization of hybrid wind-ocean energy harvesting system.



Sarjiya received the bachelor and master degrees from Gadjah Mada University, Yogyakarta, Indonesia, in 1998 and 2001, respectively, and the Ph.D. degree from the Chulalongkorn University, Thailand, in 2008, all in electrical engineering. Presently, he joint with the Electrical Engineering and Information Technology Department at Gadjah Mada University. His research interests include reliability evaluation of electric power systems, economic and secure operation of electric power systems, power systems and energy planning, and renewable energy integration.