

Modeling and Simulation of VSI Fed Induction Motor Drive in Matlab/Simulink

D. Uma, K. Vijayarekha

Department of Electrical and Electronics Engineering, SASTRA University, Thanjavur, Tamilnadu- 613 401, India

Article Info

Article history:

Received Nov 11, 2016

Revised Feb 20, 2017

Accepted Mar 4, 2017

Keyword:

Converters

Frequency conversion

Inverters

Power conversion

Pulse width modulation

converters

ABSTRACT

The theory of reference frames and switching functions are effective in analyzing the performance of the induction motor fed from VSI (Voltage Source Inverter). In this work, mathematical model of Adjustable Speed Drive (ASD) is developed by taking synchronous reference frame equations for induction motor, switching function concept for VSI and non-switching concept for diode bridge rectifier. Simulation model of induction machine is implemented using dq0 axis transformations of the stator and rotor variables in the arbitrary reference frame. The corresponding equations are given in the beginning and then the developed model is implemented using MATLAB/Simulink. In this work, the proposed model is implemented using basic function blocks. The performance of induction motor is analysed for different frequencies. The developed model is tested for the steady state behavior of machine drive. The proposed mathematical model is validated by the simulation results.

Copyright © 2017 Institute of Advanced Engineering and Science.

All rights reserved.

Corresponding Author:

D. Uma,

Department of Electrical and Electronics Engineering ,

SASTRA University ,

Thanjavur, Tamilnadu- 613 401, India.

Email: umavijay@eee.sastra.edu

1. INTRODUCTION

In many industrial applications Adjustable speed drives (ASD) are most commonly seen workhorses. In order to supply the motor with variable AC voltage or AC current with variable frequency Variable Frequency Drives (VFD) are employed. ASDs are used in pumping applications, in sugar cane industries, conveyor applications etc. The common VFD consists of a three phase diode bridge rectifier, dc link and a pulse width modulated inverter. It is necessary to develop a model for VFD for power system dynamic studies. In literature, for the three phase diode bridge rectifier dq impedance model is employed [1]. State-space averaging method is used for modeling a three phase four wire diode bridge rectifier [2]. Dynamic average value modeling methods are utilized for conventional three phase diode bridge rectifier and are validated [3]. This can capture the steady-state and transient characteristics of the diode bridge rectifier. An approximate switching function of the diode bridge rectifier is used in order to obtain the estimating function for the fundamental current harmonics [4]. This method is proven to be effective in finding out the input current harmonic content. A switching function model for voltage source inverter is derived and also it is validated using MATLAB/Simulink [5].

Modulation function theory is effectively utilized for deriving the Pulse Width Modulated (PWM) inverter which makes use of the Iterative Harmonic and Interharmonics Analysis (IHIA) [6]. Space vector pulse width modulation method is employed for inverter and the method is validated using MATLAB/Simulink [7]. A three phase boost dc-ac converter is used to supply the induction motor [8]. AC output voltage that is greater than the input dc voltage is obtained without the need of additional boost converter.

The effects of low switching frequencies in inverter fed ac drive are analyzed [9]. Both the simulation and experimental results are discussed. Model predictive current control method is employed for load current control [10]. The effectiveness of the method is validated by simulation using two level inverter. MATLAB /Simulink model is developed for a three phase inverter with PID controller and hardware is implemented using digital signal processor [11]. Total Harmonic Distortion (THD) is less for inverter with PID controller. A mathematical modeling of induction motor is derived and validated using MATLAB/Simulink [12]. Fifth order differential equations are used for modeling induction motor in synchronously rotating reference frame theory [13]. A dynamic model of three phase induction motor with double windings in the stator has been derived using space vector theory [14]. The derived model is simulated in Simulink and the steady state and dynamic characteristics are compared with the standard three phase induction motor. Three various approaches are used to obtain the squirrel cage induction motor characteristics. They are, (a) stator resistance measurement, (b) details from the motor plate and (c) induction motor modeling [11]. This is simple and cost effective approach [15]. Modeling of induction motor based on object oriented methodology is employed [16]. This model is validated on a faulty squirrel cage induction motor. A dynamic model of variable frequency drive is obtained which has the capability to ride through the fault [17]. The same is verified using case studies. Several other models for induction motor [18-19], voltage source inverter [20-21] and diode bridge rectifier [22] are available in the literature. In literature, separate models are available for the converters and induction motor.

In modern industrial applications as the induction motor is fed from switching converters, the motor model developed must be valid for arbitrary applied voltage and current waveforms. Therefore a complete model is required for power system dynamic studies and for harmonic analysis. Also, the machine model must include the essential elements of both electromagnetic and mechanical system for both steady state and transient operating conditions. Considering this, in this work an accurate model for induction motor is developed using d-q reference frame equations. Switching function concept is used for developing a model for voltage source inverter (VSI) and a non-switching concept is employed for uncontrolled rectifier. Thereby a complete and an accurate model of VFD which is required for power system dynamic studies and harmonic analysis is developed. The accuracy of the developed model has been verified through simulation in MATLAB/Simulink.

2. MODELING OF VARIABLE FREQUENCY DRIVE

2.1. Modeling of Induction Motor

The steady state equivalent circuit is derived from the principle of operation of induction motor. The steady state response of variable speed induction motor drive is evaluated based on the equivalent circuit. For validation of the design of the motor-drive system, the dynamic simulation is one of the important steps. This eliminates inadvertent mistakes in the design and resulting errors in prototype model. Therefore dynamic models are required for the induction motor [23]. The dynamic model of the induction motor is obtained from the fundamentals. The dqo model makes use of two windings for the rotor and stator of the induction motor.

Transformation of abc to dqo axes employed for deriving the dynamic model is based on simple trigonometric relationship. Used in the derivation of various dynamic models are based on simple trigonometric relationships. Since the mathematical equations of induction motor are involving differential equations that are varying with respect to time which helped to choose synchronous reference frame as the scope of this work in modeling.

The assumptions that are made in order to derive the dynamic model of induction motor are as follows,

- (1) Air gap is uniform
- (2) Stator and rotor windings are balanced, with the mmf being distributed sinusoidally
- (3) Inductance versus rotor position is sinusoidal; and
- (4) Saturation and changes of parameter are neglected.

Three particular cases for the induction machine in arbitrary reference frames are,

- (1) Stator reference frames model;
- (2) Rotor reference frames model;
- (3) Synchronously rotating reference frames model.

The model of induction motor can be done effectively using the reference frames mentioned as in [18]. Induction motor can be modeled by taking one of the generalized arbitrary reference frames, they are stator reference frame, rotor reference frame, synchronous rotating reference frames. In this work we considered implanting synchronous rotating reference frame method. Why, because the steady nature of this stator d-axis current makes this reference frame useful when a computer is used in simulation and one of advantages of this frame is speed and angular position can be taken into consideration at any instant of time.

Since the mathematical equations of induction motor are involving differential equations that are varying with respect to time which helped to choose synchronous reference frame as the scope of this work in modeling. The model equations are derived from dqo equivalent circuit of induction motor given in Figure 1.

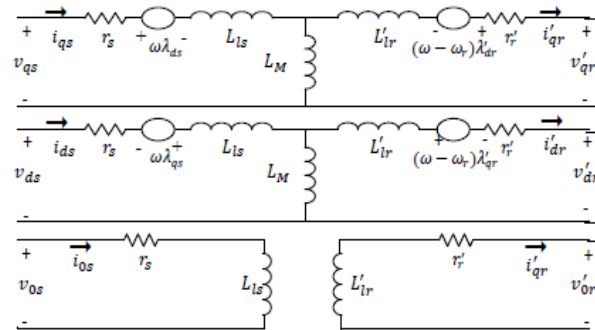

Figure 1. dqo equivalent circuit of three phase induction motor

The flux linkage equations which are written below are obtained by applying KVL and KCL to above equivalent circuit

$$\frac{d\phi_{qs}}{dt} = \omega_b \left[V_{qs} - \frac{\omega_e}{\omega_b} \phi_{ds} + \frac{R_s}{X_{ls}} \right] \tag{1}$$

$$\frac{d\phi_{ds}}{dt} = \omega_b \left[V_{ds} + \frac{\omega_e}{\omega_b} \phi_{qs} + \frac{R_s}{X_{ls}} \right] \tag{2}$$

$$\frac{d\phi_{qr}}{dt} = \omega_b \left[V_{qs} - \frac{\omega_e - \omega_r}{\omega_b} \phi_{dr} + \frac{R_r}{X_{lr}} \right] \tag{3}$$

$$\frac{d\phi_{dr}}{dt} = \omega_b \left[V_{qs} - \frac{\omega_e - \omega_r}{\omega_b} \phi_{qr} + \frac{R_r}{X_{lr}} \right] \tag{4}$$

where,

$$\phi_{mq} = X_{ML} \left[\frac{\phi_{qs}}{X_{ls}} + \frac{\phi_{qr}}{X_{lr}} \right] \tag{5}$$

$$\phi_{md} = X_{ML} \left[\frac{\phi_{ds}}{X_{ls}} + \frac{\phi_{dr}}{X_{lr}} \right] \tag{6}$$

$$X_{ML} = 1 / \left[\frac{1}{X_M} + \frac{1}{X_{ls}} + \frac{1}{X_{lr}} \right] \tag{7}$$

Current can be found by substituting flux linkages

$$i_{qs} = \frac{1}{X_{ls}} (\phi_{qs} - \phi_{mq}) \tag{8}$$

$$i_{ds} = \frac{1}{X_{ls}} (\phi_{ds} - \phi_{md}) \tag{9}$$

$$i_{qr} = \frac{1}{X_{lr}} (\varphi_{qr} - \varphi_{mq}) \quad (10)$$

$$i_{dr} = \frac{1}{X_{lr}} (\varphi_{dr} - \varphi_{md}) \quad (11)$$

Torque equation in terms of modified flux linkages and currents is given by

$$T_e = \frac{3}{2} \frac{P}{2} \frac{1}{\omega_e} (\varphi_{ds} i_{qs} - \varphi_{qs} i_{ds}) \quad (12)$$

2.2. Modeling of Voltage Source Inverter

In order to describe the function that needs to be done by the circuit, transfer function is derived. A dependent variable can be calculated in terms of its respective independent variable by using transfer function. In Pulse Width Modulation (PWM) the dependent variable is the modulated waveform and the independent variable is the waveform to be modulated. General expression of the transfer function is,

$$T_D = V_D / V_I \quad (13)$$

where, V_D is the dependent variable and

V_I is the independent variable.

There are several advantages by modelling the VSI using transfer function model.

1. Power conversion circuit can simplified into output and input variables
2. Converter topologies can be derived easily by transfer function approach
3. The strategy to implement gating pulses will become much simpler
4. Various parameters like current and voltage, load current can be calculated easily
5. For a power conversion circuits there is no need of forming real power electronic models and state equations

A particular transfer function has a particular switching function. The relationship between output variable and input variable is obtained by employing switching function theory. So to have a detailed account of the static power converters, a proper switching function must be obtained. Based on the theory of transfer function, in the VSI, the independent variables are the input voltage V_d and output current I_A , I_B , and I_C and the dependent variables are input current I_i and output voltage V_{AB} , V_{BC} , V_{CA} . Therefore, the output and input variables can be related as

$$[V_{AB}, V_{BC}, V_{CA}] = TF(V_d) \quad (14)$$

$$I_i = TF[I_A, I_B, I_C] \quad (15)$$

where TF is the Transfer Function of VSI which can expressed in the form of various switching functions.

$$TF = [SF_1, SF_2, SF_3, \dots, SF_n] \quad (16)$$

$$SF_n = \sum_{n=1}^{\infty} (A_n \sin n(\omega t)) \quad (17)$$

For three phases VSI the switching function can be classified as SF_{1A} , SF_{1B} , SF_{1C} and expressions are given below

$$SF_{1A} = \sum_{n=1}^{\infty} (A_n \sin n(\omega t)) \quad (18)$$

$$SF_{1B} = \sum_{n=1}^{\infty} (A_n \sin n(\omega t - 120^\circ)) \quad (19)$$

$$SF_{1C} = \sum_{n=1}^{\infty} (A_n \sin n(\omega t - 240^\circ)) \quad (20)$$

By the use of switching functions $SF_{1A, B, C}$ the voltages are found by

$$V_{AO} = \left(\frac{V_d}{2}\right) \sum_{n=1}^{\infty} (A_n \sin n(\omega t)) \quad (21)$$

$$V_{BO} = \left(\frac{V_d}{2}\right) \sum_{n=1}^{\infty} (A_n \sin n(\omega t - 120^\circ)) \quad (22)$$

$$V_{CO} = \left(\frac{V_d}{2}\right) \sum_{n=1}^{\infty} (A_n \sin n(\omega t - 240^\circ)) \quad (23)$$

Line voltages of the inverter is found by,

$$V_{AB} = V_{AO} - V_{BO} = \left(\frac{\sqrt{3}}{2}\right) V_d \sum_{n=1}^{\infty} (A_n \sin n(\omega t + 30^\circ)) \quad (24)$$

$$V_{BC} = V_{BO} - V_{CO} = \left(\frac{\sqrt{3}}{2}\right) V_d \sum_{n=1}^{\infty} (A_n \sin n(\omega t - 90^\circ)) \quad (25)$$

$$V_{CA} = V_{CO} - V_{AO} = \left(\frac{\sqrt{3}}{2}\right) V_d \sum_{n=1}^{\infty} (A_n \sin n(\omega t + 150^\circ)) \quad (26)$$

From the above mentioned theory the required variable for modeling of VSI is formed and can be realized readily.

2.3. Modeling of Three Phase Diode Bridge Rectifier

The ac input power is converted into dc output power by the use of three phase diode bridge rectifier. The circuit condition determines the instant at which the diode starts conducting. The input voltages V_A , V_B and V_C for the balanced condition can be written as follows:

$$V_A = V_m \sin(\omega t) \quad (27)$$

$$V_B = V_m \sin(\omega t - 120^\circ) \quad (28)$$

$$V_C = V_m \sin(\omega t - 240^\circ) \quad (29)$$

where, V_m is the voltage magnitude. For this voltages, the fundamental switching functions are expressed as same as voltage source inverter $SF_{1A, B, C}$ as mentioned in the modeling of voltage source inverter. The correlation input and output of the diode bridge rectifier are given as

$$V_d = (SF)^T V_{ABC} \quad (30)$$

$$I_{ABC} = (SF) I_d \quad (31)$$

A synchronously rotating dq frame is considered with d -axis aligned with the voltage vector. By the use of transformation matrix, three phase variables F_{ABC} hence, the three phase variables F_{ABC} are expressed in terms of such dq frame.

$$F_{dq} = T (F_{ABC}) \quad (32)$$

$$T = \begin{bmatrix} \cos(\alpha) & \cos(\alpha - 120^\circ) & \cos(\alpha + 120^\circ) \\ -\sin(\alpha) & -\sin(\alpha - 120^\circ) & -\sin(\alpha + 120^\circ) \end{bmatrix} \quad (33)$$

Combining (30) and (33) following equation can be yielded

$$V_d = \frac{3\sqrt{3}}{\pi} (V_d^2 + V_q^2)^{1/2} \quad (34)$$

where V_d and V_q are d & q axes voltage components. The equations (30) to (34) represent the non-switching model of diode rectifier

3. MATLAB/SIMULINK IMPLEMENTATION

In this section, MATLAB/Simulink is used for the simulation of three phase induction motor model [24]. The corresponding equations which are used to implement this model have been discussed in Section 1. Figure 2 shows the Simulink model of the induction motor.

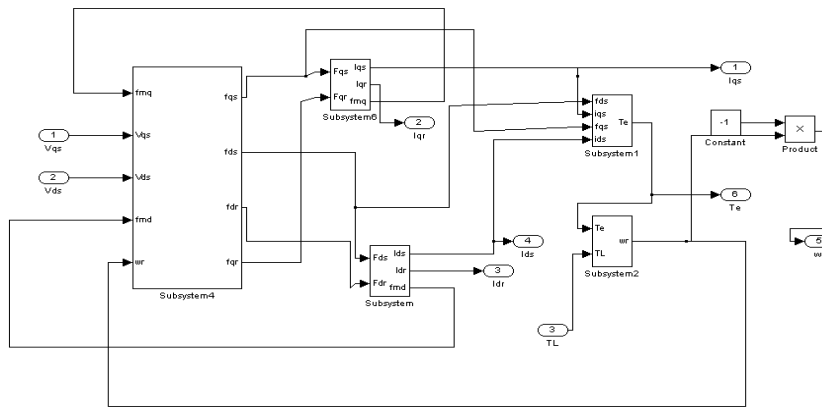

Figure 2. Matlab/Simulink model 3-phase induction motor

3.1. Simulink Implementation of Voltage Source Inverter

Simulink model of the voltage source inverter (VSI) is shown in Figure 3 which is implemented using the concept of switching function.

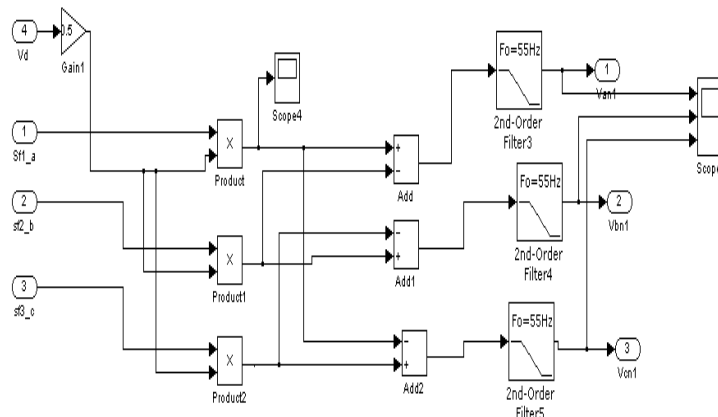

Figure 3. Voltage Source Inverter model in Matlab/Simulink

3.2. Simulink Implementation of Uncontrolled Rectifier

The switching behaviour of the diode bridge rectifier is not included in the functional modelling definition [20], thus development is based on the non switching model, as discussed previously. The equation (34) has been implemented in Simulink as shown in Figure 4. Here abc to dq0 transformation is done using synchronous reference frame concept.

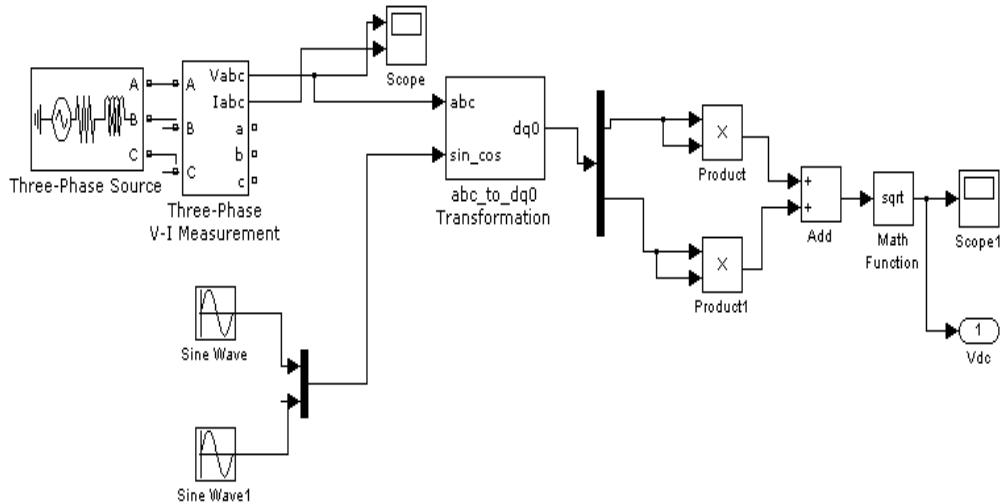

Figure 4. Matlab/Simulink model of uncontrolled rectifier

4. RESULTS AND DISCUSSION

The overall Matlab/Simulink model of VFD is given in Figure 5.

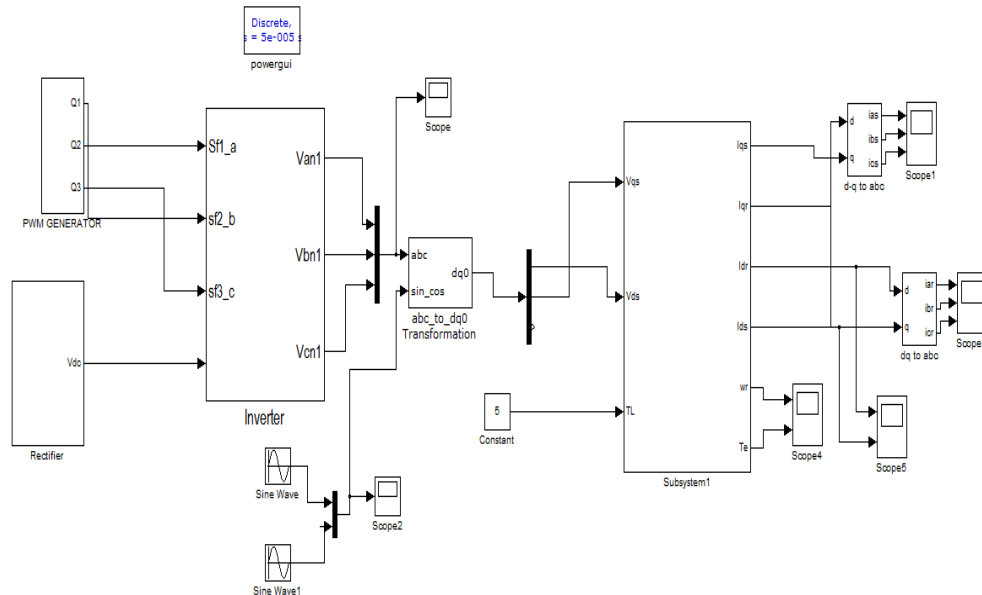

Figure 5. VFD model in Matlab/Simulink

This VFD can be operated at different frequencies ranging from 10Hz to 50Hz. Motor speed and torque for a drive operating frequency of $f_o=50\text{Hz}$ are shown in Figure 6.

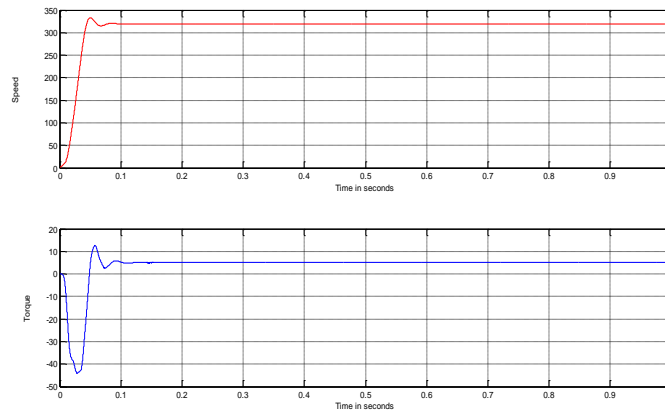

Figure 6. Motor speed and torque at $f_0 = 50\text{Hz}$.

Stator current waveforms at $f_0 = 50\text{Hz}$ are shown in Figure 7.

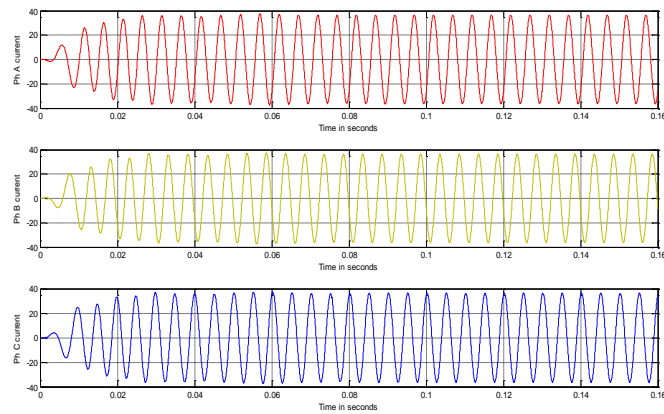

Figure 7. Stator current waveforms at $f_0 = 50\text{Hz}$

Rotor current waveforms at $f_0 = 50\text{Hz}$ is shown in Figure 8.

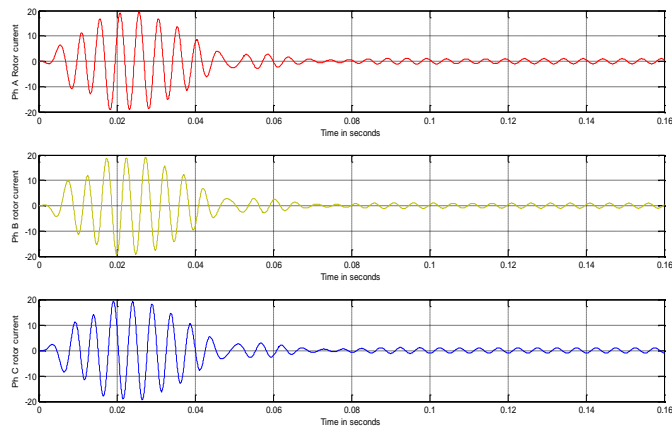

Figure 8. Rotor current waveforms at $f_0 = 50\text{Hz}$

Motor speed and torque for a drive operating frequency of $f_o = 40$ Hz are shown in Figure 9.

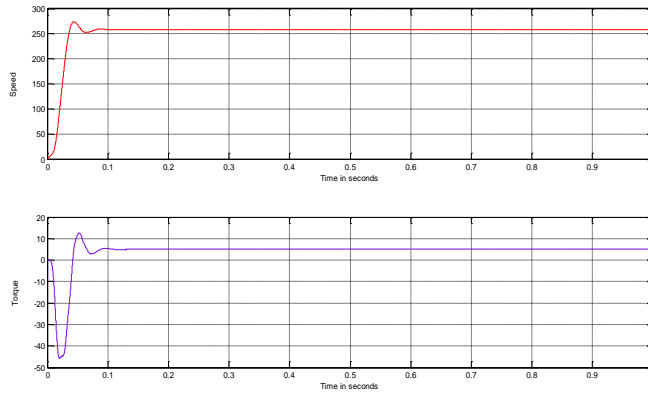

Figure 9. Motor speed and torque at $f_o = 40$ Hz.

Stator current waveforms at $f_o = 40$ Hz are shown in Figure 10.

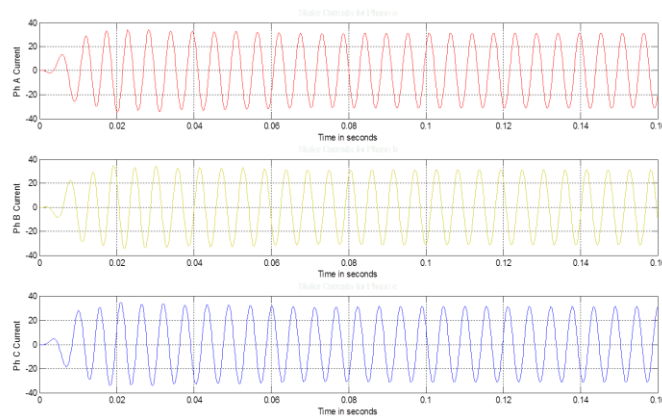

Figure 10. Stator current waveforms at $f_o = 40$ Hz

Rotor current waveforms for $f_o = 40$ Hz is shown in Figure 11.

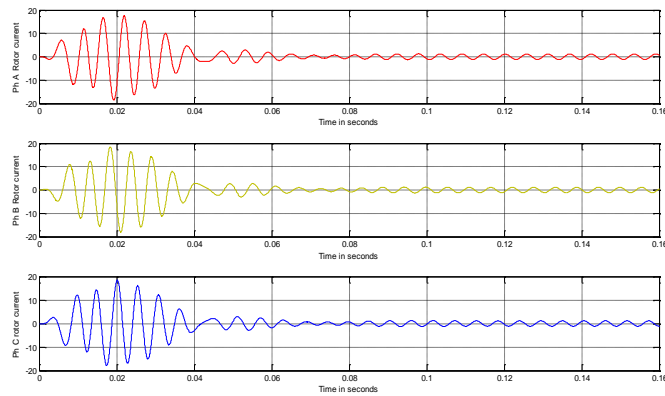

Figure 11. Rotor current waveforms at $f_o = 40$ Hz

The machine specifications are given in Table 1

Machine Specifications	
AC Source	
Source Frequency f_s	50Hz
Source Voltage (line to line)	415 V
Rectifier	
Six-Pulse Uncontrolled	
PWM Inverter	
Carrier Frequency f_c	1000Hz
Modulation frequency, f_i	10Hz to 50 Hz
Amplitude Modulation Ratio, M	0.8
Induction Motor	
Rated Power Input	3.7 kW
Voltage Rating	415 V
Rated Current	7.5A
Resistance of stator, R_s	4.9 Ω
Resistance of rotor, R_r	3.63 Ω
Leakage Inductance of stator, L_{ls}	10 mH
Leakage Inductance of rotor, L_{lr}	10 mH
Mutual (Magnetizing) Inductance, L_m	20 mH
Pairs of Poles, P	4
Operating Frequency of motor, f_o	10 Hz to 50 Hz
Rated Speed rad/sec	314 r/s

5. CONCLUSION

In this work the mathematical model of VSI Fed Induction motor with front end diode bridge rectifier is developed and described elaborately. The developed model is tested with the specifications that are obtained by conducting suitable tests on the motor with the mentioned rating. The speed and torque characteristics for different load frequencies are shown in the results. The performance of induction motor is analysed for different frequencies. The developed model is tested for the steady state behavior of machine drive. The proposed model is validated by the simulation results. Thus it can be concluded that Matlab/Simulink is reliable and easiest way to assess the behavior of ASDs using reference theory, switching function concept.

REFERENCES

- [1] Qin Lei, Sisheng Liang, Fang. Z. Peng, Miaosen Shen and Vladimir Blasko, "A Generalized DQ Impedance Model of Three Phase Diode Rectifier", IEEE Energy Conversion Congress and Exposition, pp. 3340 – 3347, Oct 2013. Available: <http://ieeexplore.ieee.org/stamp/stamp.jsp?tp=&arnumber=6647139>.
- [2] Wei Keyin, Liu Dezhi, Ou Yangbing, *et al.*, "State-Space Average-Value Model of 3-Phase 4-Wire Diode- Bridge Rectifier", IEEE International Symposium on Industrial Electronics (ISIE), pp.1634 - 1638 Aug 2009. Available: <http://ieeexplore.ieee.org/stamp/stamp.jsp?tp=&arnumber=5214095>.
- [3] S. Chiniforoosh, H. Atighechi, A. Davoudi, *et al.*, "Dynamic Average Modeling of Front-End Diode Rectifier Loads Considering Discontinuous Conduction Mode and Unbalanced Operation", *IEEE Transactions on Power Delivery*, Vol. 27, Issue. 1, pp. 421-429 January 2012. Available: <http://ieeexplore.ieee.org/stamp/stamp.jsp?tp=&arnumber=6060946>
- [4] Warit Wichakool, Al-Thaddeus Avestruz, Robert W. Cox, and Steven B. Leeb, "Modeling and Estimating Current Harmonics of Variable Electronic Loads", *IEEE Transactions On Power Electronics*, Vol. 24, Issue. 12, pp.2803-2811 December 2009. Available: <http://ieeexplore.ieee.org/stamp/stamp.jsp?tp=&arnumber=5204157>.
- [5] Byoung-Kuk Lee and Mehrdad Ehsani, "A Simplified Functional Simulation Model for Three-Phase Voltage Source Inverter Using Switching Function Concept", *IEEE Transactions On Industrial Electronics*, Vol. 48, Issue. 2, pp. 309 - 321 April 2001. Available: <http://ieeexplore.ieee.org/stamp/stamp.jsp?tp=&arnumber=915410>.
- [6] Rosario Carbone, Francesco De Rosa, Roberto Langella, Adolfo Sollazzo, and Alfredo Testa, "Modelling of AC/DC/AC Conversion Systems with PWM Inverter", *IEEE Power Engineering Society Summer Meeting*, Vol.2, pp.1004 –1009, 2002. Available: <http://ieeexplore.ieee.org/stamp/stamp.jsp?tp=&arnumber=1043550>
- [7] Dolly Roney, "Modeling and Simulation of Space Vector PWM Inverter", *IEEE International Conference on Devices and Communications*, pp. 1-4, 2011. Available: <http://ieeexplore.ieee.org/stamp/stamp.jsp?tp=&arnumber=5738466>.
- [8] Tolga Sürgevil, "Modeling and Simulation of a Boost DC/AC Inverter fed Induction Motor Drive", IEEE International Aegean Conference on Electrical Machines and Power Electronics and Electromotion, Joint Conference, pp.567 – 571, 2011. Available: <http://ieeexplore.ieee.org/stamp/stamp.jsp?tp=&arnumber=6490661>

- [9] T.A. Sakharuk, A.M. Stankovic, G. Tadmor, G. Eirea, "Modeling Of PWM Inverter-Supplied AC Drives At Low Switching Frequencies", *IEEE Transactions on Circuits and Systems I: Fundamental Theory and Applications*, Vol. 49, Issue 5, pp. 621-631, May 2002. Available: <http://ieeexplore.ieee.org/stamp/stamp.jsp?tp=&arnumber=1001951>
- [10] Ali M. Almaktoof, A.K. Raji, and M.T.E. Kahn, "Modeling and Simulation of Three-Phase Voltage Source Inverter Using a Model Predictive Current Control", *International Journal of Innovation, Management and Technology*, Vol. 5, Issue. 1, Feb 2014.
- [11] V.M. Deshmukh, A.J. Patil and P.V. Thakre, "Development of Matlab/Simulink Model for Three Phase PWM Inverter and Hardware Implementation and Testing Using DSP with Nonlinear Load", *International Journal of Control Science and Engineering*, Vol. 5, Issue 1, pp. 1-9, 2015.
- [12] Munira Batool and Aftab Ahmad, "Mathematical Modeling And Speed Torque Analysis Of Three Phase Squirrel Cage Induction Motor Using Matlab Simulink For Electrical Machines Laboratory", *International Electrical Engineering Journal (IEEJ)*, Vol. 4, No. 1, pp. 880-889, 2013.
- [13] International Electrical Engineering Journal (IEEJ) Vol. 4 (2013) No. 1, pp. 880-889 Kriti, Jatinder Singh and Vivek Pahwa, "Dynamic and Steady State Analysis of Induction Machine", *International Journal of Emerging Science and Engineering (IJESE)*, ISSN: 2319-6378, Vol.1, Issue-12, and Oct 2013.
- [14] Nysret Z. Avdiu, "Modeling of the Induction Motor with Two Sets of Three Phase Windings in the Stator and Squirrel Cage Rotor", *IEEE Industrial Electronics Society*, pp.1900 – 1907, 2012.
- [15] Velázquez-González Felipe de Jesús and Aguilar-Justo Marving Omar, "Characterizing The Squirrel Cage Induction Motor," *IEEE International Conference Mechatronics, Electronics and Automotive Engineering (ICMEAE)*, pp. 134-139, Nov 2013. Available:<http://ieeexplore.ieee.org/stamp/stamp.jsp?tp=&arnumber=6713968>
- [16] S. Bazine, K. Jelassi, G. Champenois and S. Tnani, "Object Oriented Modeling of a Squirrel Cage Induction Motor", *IEEE 32nd Annual Conference on Industrial Electronics (IECON)*, pp. 908 – 913, Nov 2006.
- [17] Xiaodong Liang and Wilsun Xu, "Modeling Variable Frequency Drive and Motor Systems in Power Systems Dynamic Studies", Xiaodong Liang and Wilsun Xu, *IEEE Industry Applications Society Annual Meeting*, pp. 1-11, 2013. Available: <http://ieeexplore.ieee.org/stamp/stamp.jsp?tp=&arnumber=6682607>
- [18] S.K. Chen, Member, H.J. Su, and G.W. Chang, "Modelling VSI-Fed ASDs by Matlab/Simulink for Harmonic and Inter Harmonic Assessment", *IEEE Proceedings of 14th International Conference on Harmonics and Quality of Power – ICHQP 2010*, pp. 1-6, 2010. Available: <http://ieeexplore.ieee.org/stamp/stamp.jsp?tp=&arnumber=5625483>
- [19] Byoung-Kuk Lee, and Mehrdad Ehsani, "A Simplified Functional Simulation Model for Three-Phase Voltage Source Inverter Using Switching Function Concept," *IEEE Transactions on Industrial Electronics*, vol. 48, issue. 2, pp. 309-321, April 2001. Available: <http://ieeexplore.ieee.org/stamp/stamp.jsp?tp=&arnumber=915410>
- [20] T. Yang, S.V. Bozhko and G.M. Asher, "Modeling of Uncontrolled Rectifiers Using Dynamic Phasors," *IEEE Electrical Systems for Aircraft, Railway and Ship Propulsion (ESARS)*, pp. 1-6, 2012. Available: <http://ieeexplore.ieee.org/stamp/stamp.jsp?tp=&arnumber=6387471>
- [21] S.K. Chen, H.J. Su, and G.W. Chang, "Modeling VSI-Fed ASDs by Matlab/Simulink for Harmonic and Inter harmonic Assessment", *IEEE proceedings of 14th International conference on harmonics and quality of power*, pp. 1-6, 2010. Available: <http://ieeexplore.ieee.org/stamp/stamp.jsp?tp=&arnumber=5625483>
- [22] Gary W. Chang, and Shin- Kuan Chen, "An analytical Approach for Characterizing Harmonics and Inter Harmonics Currents Generated by VSI fed Adjustable Speed drives", *IEEE Transactions on Power Delivery*, Vol. 20, Issue 4, 2005. Available: <http://ieeexplore.ieee.org/stamp/stamp.jsp?tp=&arnumber=1514507>.
- [23] Rajneesh Mishra, S. P. Singh, Deependra Singh and B. Singh "Investigation of transient performance of VSI-Fed IM drives Using Volts/Hz and vector control techniques", *IEEE 2nd international conference on power, control and embedded Systems*, pp.1-6, 2012. Available: <http://ieeexplore.ieee.org/xpl/articleDetails.jsp?arnumber=6508045>
- [24] M. Sathesh Kumar, P. Ramesh Babu and S. Ramprasad "Four quadrant comparative evaluation of classical and space Vector PWM-direct torque control of a VSI fed three phase induction motor drive MATLAB/SIMULINK environment", *IEEE international conference on power electronics, drives and energy systems (PEDES)*, pp. 1-6, 2012.

BIOGRAPHIES OF AUTHORS



Mrs. D.Uma was born in India on January 24, 1974. She received B.E. degree in Electrical and Electronics Engineering from Azhagappa Chettiyar College Of Engineering And Technology in 1995, India. She completed M.E degree in Power Electronics And Drives from Shanmuga College Of Engineering in 1999, India. At present She is working as Senior Assistant Professor in Electrical and Electronics Engineering department at SASTRA University, India. 7 papers are published in various international journals. Her research interests include Power quality, Electrical Drives, FACT devices and Integrated Renewable Energy Systems.



Lt. Dr. K. Vijayarekha was born in India. She received B.E. degree in Electrical and Electronics Engineering from Azhagappa Chettiyar College Of Engineering And Technology in 1990, India. She completed M.E degree in Power Systems Engineering from REC, Trichy. In 1992, India. She obtained Ph. D degree from CEERI/CSIR, Chennai, in the year 2008. At present She is working as Associate Dean in Electrical and Electronics Engineering department at SASTRA University, India. 62 papers are published in various international journals. Her research interests include Control Systems, Machine vision techniques, Image Processing, Multi-variate Image Analysis, Hyper-spectral Imaging, Non Destructive Testing, Pattern Recognition, Imaging in other modalities like ultra sound. Her ongoing research on Enhanced Defect Characterization and Classification through Ultrasonic signal and Image Analysis & Neural Networks.