

A Comparative Study between DPC and DPC-SVM Controllers Using dSPACE (DS1104)

Adel Mehdi*, Salah-eddine Rezgui*, Houssam Medouce*, and Hocine Benalla*

*Faculté des Sciences de la Technologie, Université de Constantine 1

*Département de l'électrotechnique, Rue Ain el-Bey 25000, Algérie

*Laboratoire de l'électrotechnique de Constantine LEC

Article Info

Article history:

Received Feb 9, 2014

Revised Apr 8, 2014

Accepted Apr 25, 2014

Keyword:

Direct power control
space vector modulation
switching table
power quality
converter control
harmonics, power factor

ABSTRACT

The aim of this paper is to compare two different control structures. The Simple Direct Power Control (DPC) and the Direct Power Control with Space Vector Modulation (DPC-SVM) for two level converter applications. The first strategy (DPC) has been developed to control the instantaneous active and reactive power directly by selecting the optimum switching state of the converter. Applied to the Pulse Width Modulation (PWM) converter its main feature is to improve the total power factor and efficiency, even harmonics components existence. In the second structure, the active and reactive powers are used as (PWM) control variables instead of the three-phase line currents usually used in other techniques. It is shown that DPC-SVM exhibits several properties; good dynamic response, constant switching frequency, and in particular it provides a sinusoidal line currents. Simulation and experimental results has shown that both control structures achieve good performances.

Copyright © 2014 Institute of Advanced Engineering and Science.

All rights reserved.

Corresponding Author:

Adel Mehdi

Université de Constantine 1

Rue Ain el-Bey 25000, Campus Ahmed Hammani, Constantine.

(+213)776178524

Email: adel_hdm@yahoo.com

1. INTRODUCTION

As DC power supplies are extensively used, not only in industrial fields, but also in consumer products, several problems with regard to their diode rectifiers have been observed in recent years, like the low input power factor, and the presence of harmonics in the input currents. Consequently, the pulse width modulation (PWM) converters are adopted in applications that require less distortion in the current waveforms, thus the unity power factor operation can be easily performed by regulating the currents in phase with the power-source voltages [1].

Development of control methods for PWM rectifiers was possible thanks to advances in power semiconductor devices and digital signal processors, which allow fast operation and cost reduction. It offers possibilities for implementation of sophisticated control algorithms. Appropriate control can provide both the rectifier performance improvements and reduction of passive components. Various control strategies have been proposed in recent works for this type of PWM rectifier [2]. A well-known method of indirect active and reactive power control which is based on current vector orientation with respect to the line voltage vector (voltage oriented control VOC) [3].

VOC guarantees high static performance via internal current control loops. However, the final configuration and performance of the VOC system largely depends on the quality of the applied current control strategy [4]. Another less known method based on instantaneous direct active and reactive power control is called direct power control (DPC) [1][5]. But both strategies mentioned do not perform sinusoidal current when the line voltage is distorted. Only DPC based on virtual flux [6] instead of the line voltage vector orientation [7], called VF-DPC, provides sinusoidal line current and lower harmonic distortion [6].

However, it contains a several disadvantages as:

- Variable switching frequency (difficulties of LC input filter design)
-

- High sampling frequency needed for digital implementation of hysteresis comparators
- Fast microprocessor and A/D converters requirements

Therefore, it was difficult to implement VF-DPC in industry. But all of the above drawbacks can be eliminated when instead of the switching table a PWM voltage modulator is applied [8].

2. DIRECT POWER CONTROL

Direct power control is based on the same control principles as in the direct torque control technique (DTC). In DTC, it's the electromagnetic torque and the rotor flux which are directly controlled, while in DPC, it's the stator active and reactive powers that are directly controlled [9]. Also, in DPC no internal current control loops or PWM modulator block are required, because the converter switching states are selected by a switching table based on the instantaneous errors between the commanded and measured values of active and reactive power. Therefore, the main feature of the DPC implementation is a correct and fast extraction of the active and reactive power [1].

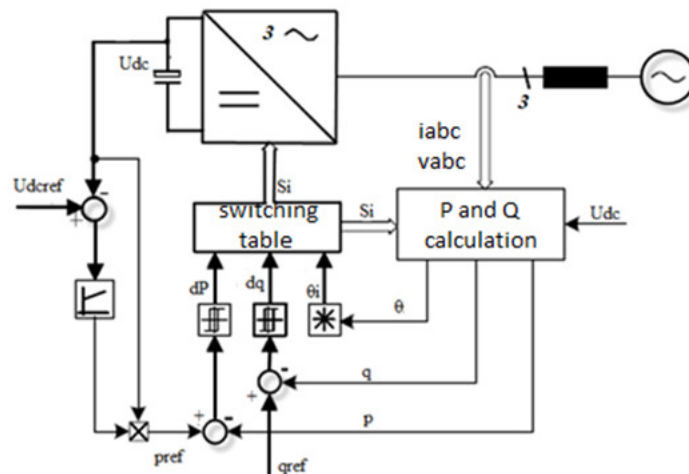

Figure 1. Configuration of DPC Controller for PWM converter [6]

2.1. Instantaneous Power Source Calculation

the active and reactive powers are obtained by the following equations

$$P = v_a i_a + v_b i_b + v_c i_c \quad (1)$$

$$Q = \frac{1}{\sqrt{3}} [v_a (i_c - i_b) + v_b (i_a - i_c) + v_c (i_b - i_a)] \quad (2)$$

2.2. Line Voltage Vector Position

The phase of the power-source voltage vector is converted to the sector signal θ_i . For this purpose, the stationary coordinates are divided into 12 sectors, as shown in Table I, and the angle can be deduced from equation (3) [5].

$$\theta = \arctan \left(\frac{v_\beta}{v_\alpha} \right) \quad (3)$$

2.3. Switching Table

the selection of the adequate vector is determined by the following table according to the variation in the active and reactive power with the position of voltage vector.

Table 1. Switching Table

dq	qp	θ_1	θ_2	θ_3	θ_4	θ_5	θ_6	θ_7	θ_8	θ_9	θ_{10}	θ_{11}	θ_{12}
0	0	6	1	1	2	2	3	3	4	4	5	5	6
0	1	6	7	1	0	2	7	3	0	4	7	5	0
1	0	1	2	2	3	3	4	4	5	5	6	6	1
1	1	7	7	0	0	7	7	0	0	7	7	0	0

3. DIRECT POWER CONTROL WITH PWM

The DPC-SVM with constant switching frequency uses closed-loop power control, as shown in Figure 2. The commanded reactive power Q_{ref} set to zero for unity power factor operation and delivered from the outer PI dc voltage controller. The reference active power P_{ref} and reactive power Q_{ref} which are in the DC frame and flowing between the supply and the dc link are compared with the calculated P_{mes} and Q_{mes} respectively. The errors are delivered to a PI controller to eliminate steady-state error, and the output signals are transformed to the fixed frame and used for switching signals generation by the space-vector modulator (SVM)[10].

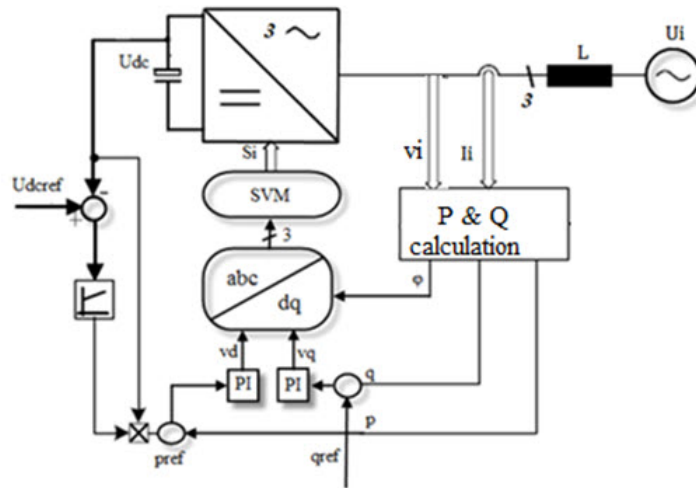

Figure 2. Configuration of DPC-SVM Controller for PWM converter

3.1. Synthesis of Active and Reactive Power Controllers

The synthesis of active and reactive power controllers can be done analytically using a simplified model. In this model the switching waveforms created by the PWM converter are replaced by its average value within the switching period [3]. The active and reactive power in (dq) coordinates has the form after orientation the frame.

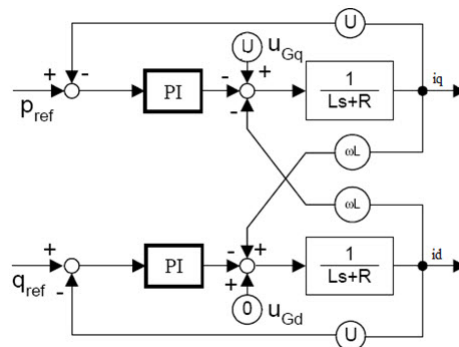

Figure 3. Simplified block diagram[8]

$$P = UI_{qs} \tag{4}$$

$$Q = -UI_{ds} \tag{5}$$

4. SIMULATION RESULTS

4.1. Direct Power Control

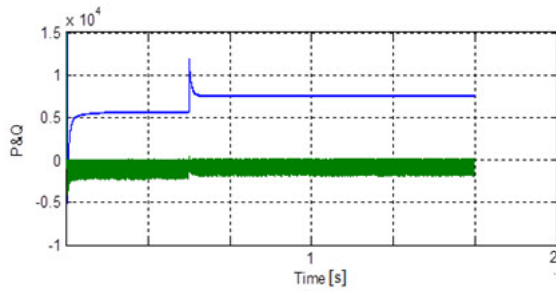

(a)

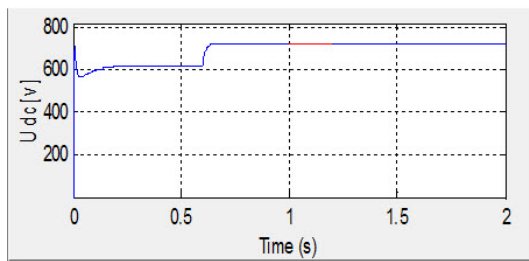

(c)

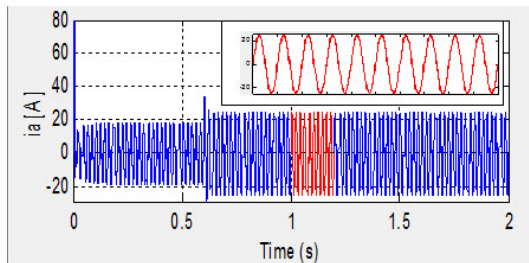

(e)

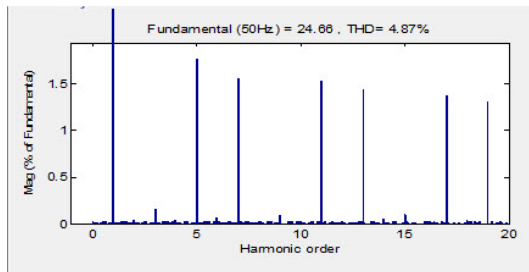

(g)

4.2. Direct Power Control with Modulation

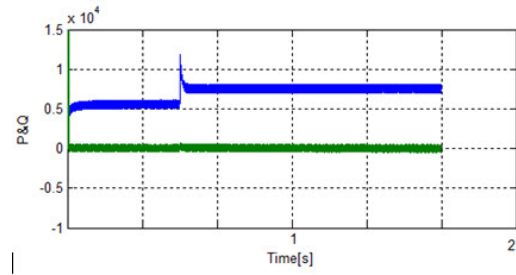

(b)

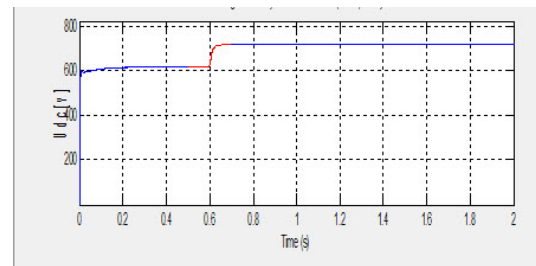

(d)

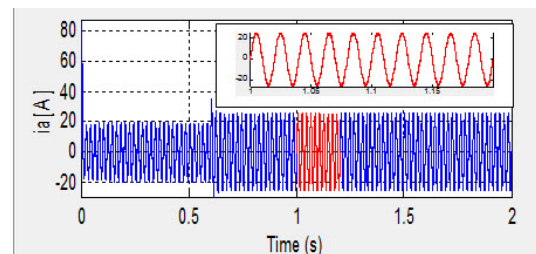

(f)

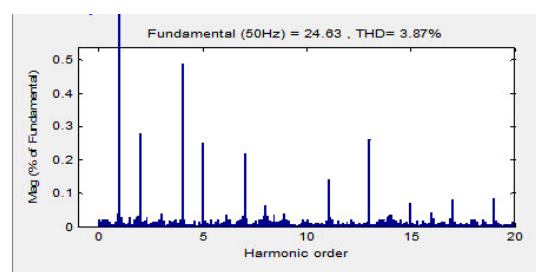

(h)

Figure 4. Simulated basic signal waveforms and line current harmonic spectrum under purely sinusoidal line voltage for DPC. From the top: instantaneous active and reactive power, DC link voltage, line current, and harmonic spectrum of the line current (THD = 4.87%).

Figure 5. Simulated basic signal waveforms and line current harmonic spectrum under purely sinusoidal line voltage for DPC-SVM. From the top: instantaneous active and reactive power, DC link voltage, line current, and harmonic spectrum of the line current (THD = 3.87%).

5. EXPERIMENTAL RESULTS

5.1. Direct Power Control

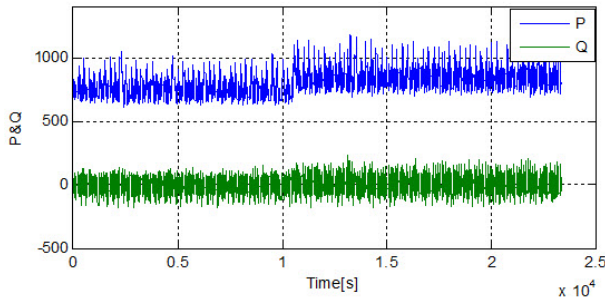

(a)

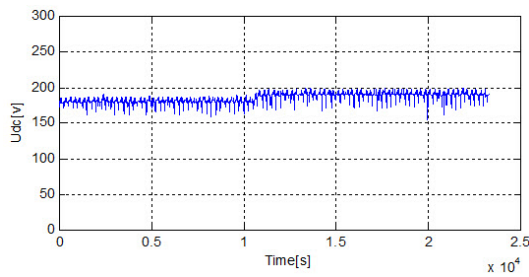

(c)

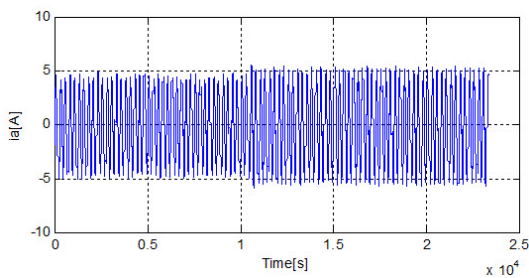

(e)

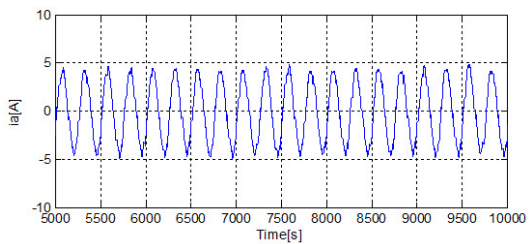

(g)

5.2. Direct Power Control with Modulation

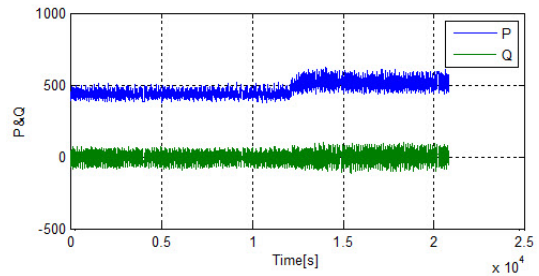

(b)

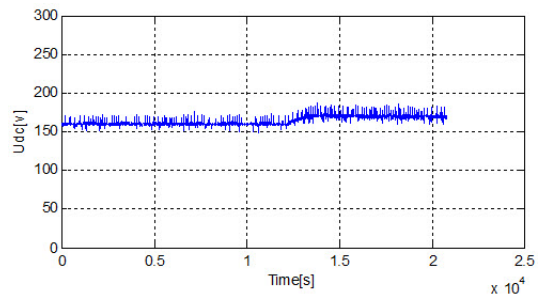

(d)

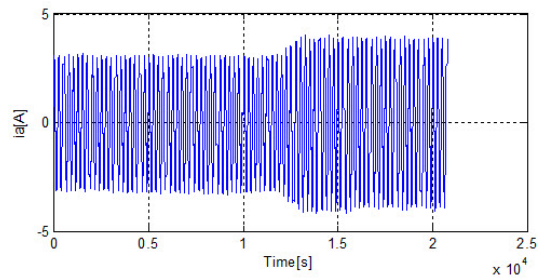

(f)

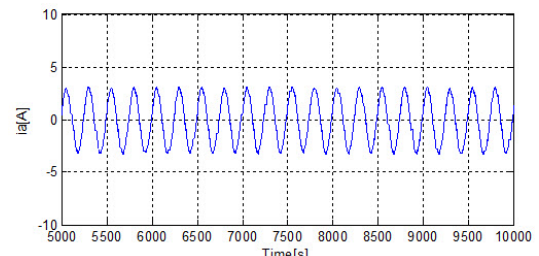

(h)

Figure 6. Experimental results for DPC. From the top: instantaneous active and reactive power, DC link voltage, line current, and a focused part of the line current.

Figure 7. Experimental results for DPC-SVM. From the top: instantaneous active and reactive power, DC link voltage, line current, and a focused part of the line current.

6. EXPERIMENTAL SYSTEM CONFIGURATION

An experimental study has been developed to examine operating characteristics of both techniques DPC and DPC-SVM. The power circuit of the PWM converter is constituted by an insulated gate bipolar transistor (IGBT)-

based full-bridge (SEMIKRON) circuit. The electrical parameters are shown in Table II. Hall-effect current and voltage sensors (LEM LA 25-NP) and (LEM LV 25-P) are employed to detect the line currents and voltages and the dc-bus voltage. The estimation of the instantaneous power and the voltages is proceeded by a dSPACE card (DS1104), it is essential to make the control period as short as possible, because the estimating equations have to be changed every time of the switching state of the converter is changed. The interface circuits which deal with detection of the line currents are specially designed to attain a fast data acquisition corresponding to the control period of the DSP [4]. For this purpose, high-sampling-rate and high-resolution analog-to-digital converters (ADC's-12bit) are employed in the system. All symbols that have not been mentioned in the equation should be explained in the following text.

Table 2. Parameters Used In Simulation

Power	7(kW)	Grid side inductor	2e-3(H)
Grid voltage	250(V)	Grid side resistor	3.87e-3(Ω)
DC link voltage	720(V)	DC link capacitor	1e-3(F)
Current	24(A)	Load resistor(DC link)	68.8(Ω)
Switching frequency	10(kHz)	Simple time (DPC)	1e-6(S)
Grid frequency	50(Hz)	Simple time (DPC-SVM)	2e-6(S)

Table 3. Parameters Used In Experiment

Power	800(W)	Grid side inductor	25e-3(H)
Grid voltage	104(V)	Grid side resistor	0.7(Ω)
DC link voltage	190(V)	DC link capacitor	1.1e-3(F)
Current	4(A)	Load resistor(DC link)	68.8(Ω)
Switching frequency	10(kHz)	Simple time (DPC)	8e-5(S)
Grid frequency	50(Hz)	Simple time (DPC-SVM)	8e-5(S)

6.1. Simulation Results and Analysis

Fig.4-A and Fig.5-A show the behaviours of the instantaneous active and reactive power under step variation, between 5 and 7 kW we can see that the responses of both structure provides an excellent performances, the quick variation of the active power don't affect the reactive power which is keeping at his references (value 0 VAR), thus, decoupled control between active and reactive power is achieved.

Fig.4-B and Fig.5-B show the DC link capacitor voltage, when a step voltage is applied at $t=0.6s$, one can see, that the DPC-SVM structure need 0.1s to attend the references value.

The phase current i_a waveform is depicted on the Fig.4-C and Fig.5-C, the FFT analysis displays the frequency spectrum of the current grid. As expected, The Total Harmonic Distortion (THD) is displayed above the spectrum (THD=4.87% for DPC and THD=3.87% for DPC-SVM).

6.2. Experimental Results and Analysis

Several experimental tests have been done to verify feasibility of the proposed techniques. Fig.6 and Fig.7 presents the experimental results under the unity power factor operation in the steady state. The power dissipated in the load resistance was 750 (W) in DPC and 450 (W) in DPC-SVM, it can be seen that the power-source voltage is successfully estimated. The line current i_a shown on Fig.6(C-D) and Fig.7(C-D) is in phase with the actual power-source voltage because the reactive power is controlled to be zero. The current waveform slightly contains lower order harmonic distortion.

Fig. 6-A; Fig. 7-A; presents results of a step response against the disturbance load power under the unity power factor operation. The load power was changed stepwise from 750 to 850 (W) in DPC and from 450 to 550 (W). It can be observed that the estimation of the power and voltages can be performed and that the unity power factor operation is successfully achieved, even in transient state, it can be observed that the active power control and the reactive power control are independent of each other.

7. CONCLUSION

This paper has described two concepts to improve the total power factor and efficiency of the PWM converter. The first method is direct instantaneous active and reactive power control of the converter, in this method the active and reactive power can be regulated directly by relay control of the power, which is implemented by hysteresis comparators and a switching table. In this configuration, the errors between the power commands and the feedback signals are compared by the hysteresis elements, and the specific switching state of the converter is appropriately selected by the switching table, so that the errors can be restricted within the hysteresis bands.

Also it is shown that DPC-SVM has proven excellent performance and verifies the validity of the proposed control system. The DPC-SVM system constitutes a viable alternative to the conventional control strategies and it has the following features and advantages:

- Lower sampling frequency (than a conventional DPC)
- Good dynamic response
- Offers sinusoidal line currents (low THD), for ideal and distorted line voltage
- Constant switching frequency

ACKNOWLEDGEMENT

we would like to thanks all members of (Laboratoire de l'électrotechnique de Constantine LEC) for your helps to complete this work .

REFERENCES

- [1] Noguchi et al. "direct power control of PWM converter without power-source voltage sensors". *Industry Applications, IEEE Transactions on*, 34(3):473–479, 1998.
- [2] Kazmierkowski. "control strategies for PWM rectifier/inverter-fed induction motors". In *Industrial Electronics, 2000. ISIE 2000. Proceedings of the 2000 IEEE International Symposium on*, volume 1, page TU15–TU23. IEEE, 2000.
- [3] Lechat. "voltage oriented control of three-phase boost PWM converters". 2010.
- [4] Malinowski et al. "a comparative study of control techniques for PWM rectifiers in AC adjustable speed drives". *Power Electronics, IEEE Transactions on*, 18(6):1390–1396, 2003.
- [5] Serpa et al. "a modified direct power control strategy allowing the connection of three-phase inverters to the grid through LCL filters". *Industry Applications, IEEE Transactions on*, 43(5):1388–1400, 2007.
- [6] Serpa et al. "virtual-flux direct power control for mains connected three-level npc inverter systems". In *Power Conversion Conference-Nagoya, 2007. PCC'07*, page 130–136. IEEE, 2007.
- [7] Hu et al. "direct active and reactive power regulation of grid-connected DC/AC converters using sliding mode control approach". *Power Electronics, IEEE Transactions on*, 26(1):210–222, 2011.
- [8] Malinowski et al. "simple direct power control of three-phase PWM rectifier using space-vector modulation (DPC-SVM)". *Industrial Electronics, IEEE Transactions on*, 51(2):447–454, 2004.
- [9] Tremblay et al. "direct power control of a DFIG-based WECS with active filter capabilities". In *Electrical Power & Energy Conference (EPEC), 2009 IEEE*, page 1–6. IEEE, 2009.
- [10] Restrepo et al. "a simple switch selection state for SVM direct power control". In *Industrial Electronics, 2006 IEEE International Symposium on*, volume 2, page 1112–1116. IEEE, 2006.

BIOGRAPHY OF AUTHOR



Adel Mehdi is a Ph.D. student and member at the electro-technique laboratory of Constantine LEC with Master of management and transformation of Electrical Energy from University of Constantine 1 Algeria (2011). He obtained Licence Degree in Electrical Engineering from Institute the sciences of Technology in 2009. His researches are in fields of control systems , digital signal processing,direct power control, microprocessors, renewable energy, and micro-grids. He is affiliated with IEEE as student member from 2012.and at university agency of francophone AUF from 2011.