

Fuzzy PI Controllers Performance on Boost Converter

Wakhyu Dwiono*

* Departement of Telecommunication Engineering, Polytechnic of Caltex Riau

Article Info

Article history:

Received Jan 23, 2013

Revised Mar 2, 2013

Accepted Mar 12, 2013

Keyword:

AVR microcontroller

Boost Converter

DC to DC converter,

Fuzzy-PI

ABSTRACT

Electric voltage of about 220 volts is required to supply the home appliance in Indonesia, such as for lighting lamps. When there is no 220 volts power supply, while the available voltage source is equal to the battery voltage of about 1.5 to 12 volts, it requires the voltage converter to convert a low voltage 220 volts Become. By using a transformer, it is easy to rise the AC voltage. Meanwhile for DC voltage, the transformer can not be used to raise it, Because The changing magnetic field do not occur then the output of transformer voltage is not higher but the transformer Become hot Because of DC voltage. To raise the DC voltage, DC to DC converter is needed, such as Boost Converter. Boost Converter works based on the changing current that flows through an inductor. This current change will Affect the inductor voltage change. The output voltage of boost converter has a unique comparison to the input voltage duty cycle. By adjusting the amount of the voltage duty cycle, the output voltage will be easy to control. In this paper, we presented a prototype of 12 to 220 V DC-DC boost converter, using fuzzy-PI intervention that being embedded on ATmega168 AVR microcontroller. The controller can maintain a fixed output voltage by regulating the input duty cycle. From the test results, is obtained an efficiency of 75% at 15 watts whereas percentage of error of about less than 3%.

Copyright © 2013 Institute of Advanced Engineering and Science.
All rights reserved.

Corresponding Author:

First Author,

Departement of Telecommunication Engineering,

Polytechnic of Caltex Riau,

Jl Umbansari 1 Rumbai Pekanbaru 28165 Riau Indonesia.

Email: wakhyudwi@gmail.com

1. INTRODUCTION

The clean energy resources that can be harnessed and available in large quantities are wind power, waterfall and sun light. Wind power and solar energy has a high flexibility because they are available in all around the world, and easy to convert to electrical energy. The electrical energy that being generated by wind power and sunlight may vary at any time, so if this energy will be used as a source of electrical energy, we need a system that can manage the energy to the well regulated electrical energy, especially on the magnitude of the voltage. This is necessary because the equipments to be supplied, are requiring a relatively constant voltage. The batteries are needed to maintain the continuity of electrical energy that being generated by wind and solar power.

Generally, the battery voltage is low enough, ie in the range of 1.5 volts to 12 volts. To increase the voltage, we need a DC to DC converter or commonly known as a Boost Converter. Some methods of controlling the output voltage of the boost converter has been developed, such as using a generalized PID [1], controls the changing frequency [2], the method of duty cycle addition and subtraction [3], a scheme of arrangement multiple loop [4] and optimal control [5].

From all of controllers were mentioned above, all design are using a complex analytic approach. In this paper, we discuss the performance of fuzzy PI controller on 12 to 220V boost converter This performance is measured in rise time, percentage of error and efficiency.

2. RESEARCH METHOD

DC to DC boost converter system works by comparing the reference voltage to the output voltage systems. then the difference of the comparison is used by the fuzzy and PI controller to determine the duty cycle. The determined duty that being resulted by fuzzy and PI controller then being combined to switch electrical currents toward the inductor.

2.1. Boost Converter

Boost converter convert input DC voltage into DC voltage output with a larger voltage [6]. The magnitude of the output voltage can be varied by changing the duty cycle (D) of the switching signals. The magnitude of the voltage and current ratios are shown in equations 1 and 2. The basic circuit of the boost converter (shown in Figure 1) consists of an inductor, and two switches (transistors and diodes could be).

$$V_{out} = \frac{1}{1-D} V_{in} \quad (1)$$

$$I_{in} = \frac{1}{1-D} I_{out} \quad (2)$$

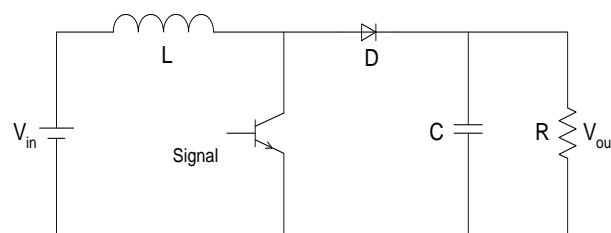

Figure 1. The basic circuit boost converter.

2.2. Boost Converter

From Equation 1, the output voltage can be adjusted by changing the magnitude of the signal duty cycle switching. This conditions can be maintained during the load under normal conditions. When the load changes, there will be a change at output voltage. If the load is too large (small resistance value), the output voltage will decrease. Therefore it is necessary to maintain the output voltage according to the reference.

The controller is designed in order to emit signals with it'sduty cycle that corresponds to the occurring error. The controller can be designed analytically using feedback analysis approach to form generalized Lyapunov status PID [1], this type of controller can make the output voltage follows the reference trajectory very well. Other type of controller isan optimal controller that was designed with a different approach on two nonlinear models of the system [5]. In the simulation, the controller can drive the system trajectories according to the characteristics of a good closed loop. Another control strategy is the sliding mode control [4]. This can be done by dividing the system into two schemes conditions or double loops. The controller is implemented in the simulation and hardware. Test results of simulation and experiment showsan excellent performance.

2.3. Fuzzy PI

Generally, fuzzy controller hasfour parts, fuzzification, rule base, inference mechanism and defuzzification, as illustrated in Figure 2[7], it can be implemented as controller in PI like structure [8]. This type controller has two inputs, error and delta error, as shown in Figure 3. Then the controller output is integrated. Fuzzy-PI controller has the performance as PI controller, but it has a simplicity in the design process.

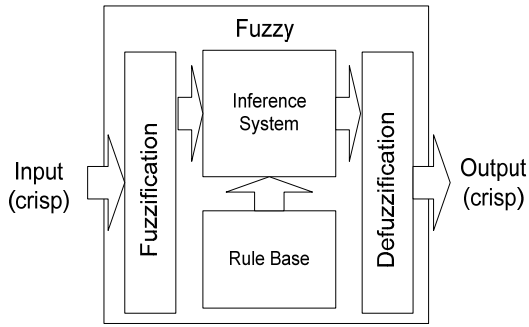

Figure 2. Block diagram of fuzzy logic system

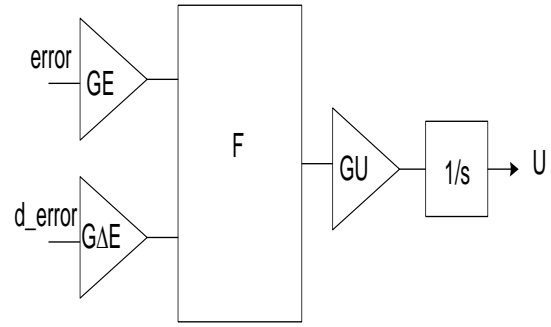

Figure 3. Block diagram of fuzzy PI controller

The parameters of the fuzzy PI controller are the gain of error (GE), gain of error change (GΔE) and the gain of the output (GU).

2.4. Design of System

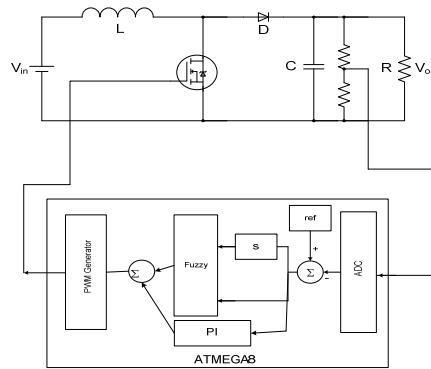

Figure 4. Block diagram of DC to DC boost converter

This DC to DC boost converter block diagram is shown in Figure 4. The system consists of a basic circuit dc to dc boost converter, and microcontroller ATMEGA 8 blocks. Fuzzy PI controller was realized using Codevision AVR. ADC and PWM generator are available on ATMEGA 8, which can be accessed using the software. Inductance and capacitor values are chosen by using differential equations, while the MOSFET chosen is IRF840 type, because this type are able to pass currents of up to 8 Ampere and VDSS about 500V.

The input set of fuzzy membership functions is using three pieces of triangular membership function (shown in Figure 5), the output set is using three singleton (Figure 6), fuzzy rules base is shown in Table 1, and using mamdani inference system.

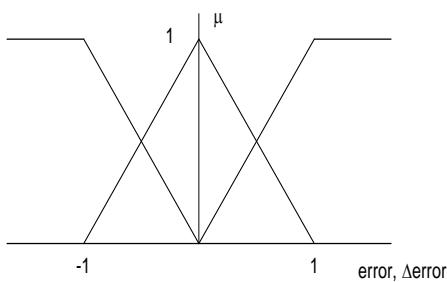

Figure 5. Input fuzzy membership function set

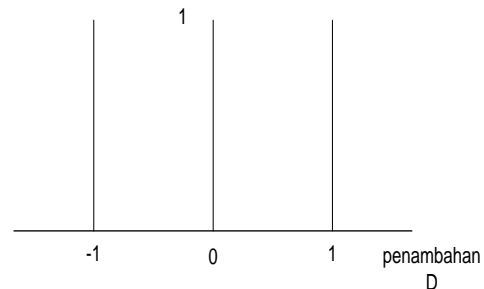

Figure 6. Output fuzzy membership function set

Table 1. Fuzzy rule.

		Error		
		EN	EZ	EP
$\Delta Erro$	r	-1	-1	0
	ΔEN	-1	0	1
	ΔEP	0	1	1

3. RESULTS AND ANALYSIS

DC to DC converter system was tested by giving a load on the output voltage converter. Measured data is input power, output power and the output voltage response. The input power is obtained by measuring the input current and input voltage (current and voltage of battery), while the output power of the data obtained by measuring current and voltage of the loads.

Output voltage data were measured every 0.1 seconds and then the data is transmitted using serial communication via USB port (via a series downloader K125). Data received by the PC using hyperterminal facility. Voltage data set that has been stored, then converted into graphical form using Matlab. Prototype of the system DC to DC boost converter is shown in Figure 8.

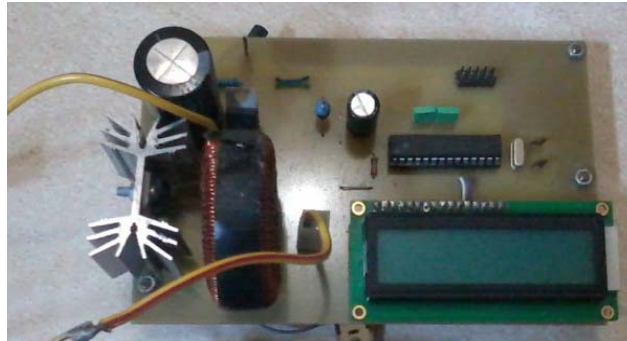

Figure 8. Prototype of DC to DC boost converter.

3.1. No Load Output Voltage

Figure 9 is a graph of the converter output voltage with no load by using three different controllers. Comparison of three different controllers data can be seen in Table 2.

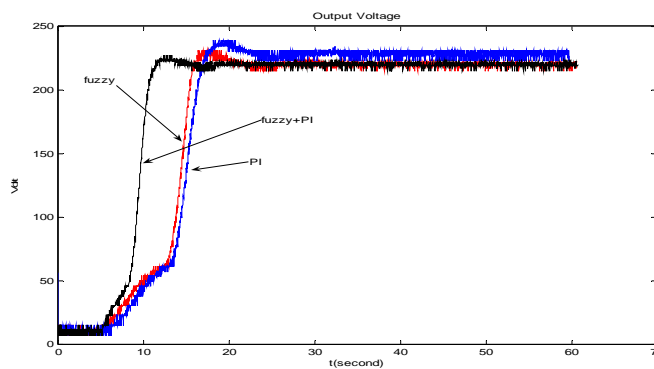

Figure 9. Graph of the output voltage with no load for three different controllers.

Table 2. Comparison of Performance of Three Controllers with no load

Controller	Over Shoot (%)	Rise Time (second)	Vo (volt)	Error (volt)
PI	4.8	10	228.7	-8.7
Fuzzy	4.8	9	219.46	0.54
Fuzzy+PI	3.2	5	219.42	0.58

From Table 2 it can be seen that the fuzzy + PI controller has the best performance if it is compared to the fuzzy and PI controller. It has a rise time about 5 seconds, over shoot percentage about 3.2% and the error is about 0.58 volts.

3.2. Output Load 9 Watts

Figure 10 and 11 is a graph of the converter output voltage that being loaded with converter 9 watts using three different controllers. Comparison of data between the three controllers can be seen in Table 3.

Table 3. Comparison of three controllers with loads of data

Controller	Rise Time (second)	Vo (volt)	Error (volt)
PI	10	218,82	1,08
Fuzzy	10	217,05	2,95
Fuzzy+PI	5	216,19	3,81

Table 3 shown that the fuzzy + PI controller has the fastest response. It only takes 5 seconds to achieve a settle condition, but it has an error of 3.81 volts. While the PI and Fuzzy controllers have the same response time, which takes 10 seconds to reach the settle condition. Among the three controllers, PI controller has the smallest error.

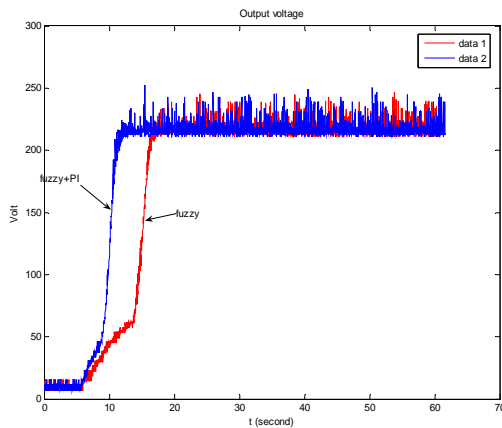

Figure 10. Comparison of output voltage using PI + fuzzy controller and fuzzy

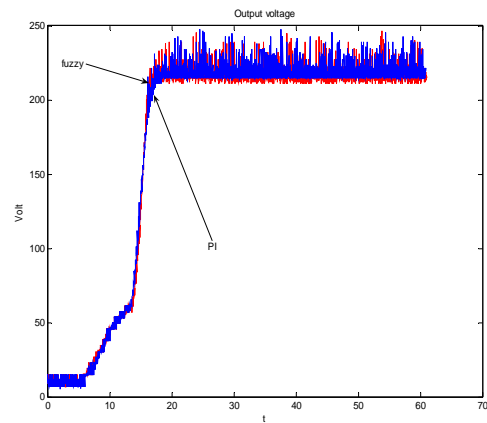

Figure 11. Comparison of output voltage using fuzzy and PI controller

3.3. Varying Output Load

In this test, the output voltage of DC to DC converters is loaded with energy saving lamps 7 watts, 15 watts and 23 watts. The data test results are shown in Table 4, it can be seen from this table that the greatest efficiency is when the converter is loaded with 7 watts about 79.9%. With increasing the power of load then the efficiency is decreasing about 75.2% at 15 watts and then getting smaller again to 44.01% at 23 watts. Based on these data it can be concluded that this converter has an output power up to 15 watts (in terms of efficiency is in the range of 70%).

Table 4. Data converter testing using varying load

No	Beban	Sisi Input			Sisi Output			Efisiensi (%)
		V(volt)	I (amper)	P (watt)	V (volt)	I (amper)	P (watt)	
1.	Tanpabeban	12	0.1	1.2	230	-	-	-
2.	7 watt krisbow	11	0.64	7.04	225	0.025	5.63	79.9
3.	15 watt Hori	11	1.36	14.96	225	0.050	11.25	75.2
4.	23 watt Hori	10	4.09	40.9	225	0.080	18	44.01

4. CONCLUSION

From the testing results, it can be taken some conclusions,

1. PI, Fuzzy and Fuzzy+PI can control the output voltage properly.
2. With no-load test, fuzzy + PI controller has the best performance among the used controllers which has a rise time is 5 seconds, percentage of over shoot about 3.2% with 0.58 volts error.
3. For load testing with 9 watts, fuzzy + PI controller has the fastest rise time (about 5 seconds), despite the large error is 3.81 volts.
4. System DC to DC Boost Converter has realized has an output power of 15 watts with an efficiency of 75.2%.

For further development, the application of fuzzy controller on the system DC to DC Boost converter is how to improve the system output and higher efficiency.

REFERENCES

- [1] Herbertt Sira-Ramirez, Gerardo Silva-Navarro. *Generalized PID control of The Average Boost Converter Circuit Model*. European Union Nonlinear Control Network Workshop. Sheffield England, June 25-27th, 2001.
- [2] Chongming (Michael) Qiao, Jason Zhang. Control of Boost type Converter in Discontinuous Conduction Mode by Controlling the Product of Inductor Voltage-Second. Recife, Brazil. PESC 2005.
- [3] Syafrudin Masri Pui-Weng Chan. Development of a Microcontroller-Based Boost Converter for Photovoltaic System. *European Journal of Scientific Research*. 2010; 41(1): 38-47.
- [4] Pablo Sanchis, Alfredo Ursaea, Eugenio Gubia, Luis Marroyo. Boost DC-AC Inverter: A new Control Strategy. *IEEE Transactions On Power Electronics*. 2005; 20(2).
- [5] A Giovanni Beccuti, Georgios Papafotiou, Manfred Morari. *Optimal Control of the Boost dc-dc Converter*. Proceedings of the 44th IEEE Conference on Decision and Control, and the European Control Conference, Seville, Spain. 2005.
- [6] Phillip T Krein. *Elements Of Power Electronics*. Oxford University Press: New York. 1998.
- [7] Kevin M Passino, Stephen Yurkovich. *Fuzzy Control*. Addison-Wesley, California. 1998.
- [8] Jan Jantzen. *Foundation of Fuzzy Control*. John Wiley and Son. Chichester. 2007.

BIOGRAPHY OF AUTHOR



Wakhyu Dwiono, received Bachelor Degree in Electrical Engineering from Diponegoro University Semarang Indonesia in 1999. He received Master Degree in Electrical Engineering from Bandung Institute of Technology Indonesia in 2005. He is lecturer and member of wireless communication research group at Telecommunication Department at Polytechnic of Caltex Riau