

## Fault Detection Approaches to Power System: State-of-the-Art Article Reviews for Searching a New Approach in the Future

Pituk Bunnoon\*

Electrical Engineering Department, Faculty of Engineering, Rajamangala University of Technology Srivijaya

---

### Article Info

#### Article history:

Received May 7, 2013

Revised Jul 4, 2013

Accepted Jul 15, 2013

---

#### Keyword:

Fault detection  
Power System  
Review Article  
State of the Art  
Transmission Line

---

### ABSTRACT

This paper proposes the state-of-the-art of fault detection approach a power system. Several articles present edit in each implementation and method from the last to present (2013). The advantage of the approach would be developed to the new detection in the future. Many interested topics used for detection of fault in the power system. In this research can be classified into two types interesting in fault detection. This review of many papers will be used to develop the research or find the new method for appropriate fault detection in the power system.

Copyright © 2013 Institute of Advanced Engineering and Science.  
All rights reserved.

---

### Corresponding Author:

Dr. Pituk Bunnoon

Affiliation Electrical Engineering, Faculty of Engineering,  
Rajamangala University of Technology Srivijaya

Address 1 Rajdamniennok road, Songkhla district, Songkhla province 90000, Thailand

Phone+6674501438

Email: add2002k@hotmail.com, pituk.b@rmutsv.ac.th

---

## 1. INTRODUCTION

In the power system, fault is one of system problem occurred in the present. It can be made the part or all systems fail. The major types of fault are symmetrical and unsymmetrical faults. The faults are anovercurrent in the circuit mainly due to a short circuit. They may occur in three phase power system: single phase to ground, phase to phase, two phases to ground, phase to phase and another phase to ground, all phases to ground, three phase short circuit. The first four events above are unsymmetrical fault and also the latter two events are symmetrical fault in power system. To cause a short circuit in the power system is not good for the system. But if it happens in the system will affect the power transmission or distribution immediately if it is still in the system. The details will be explained in the next section.

The corrective and preventive systems so happens to care if a short circuit occurs, call fault detection. The function of the detector circuit is that monitors the system over time. In order to facilitate rapid removal of a disturbance from the power system, the system is divided into protection zones. Relays monitor the system quantities (current, voltage) appearing in these zones. If a fault occurs inside a zone, the relays operate to isolate the zone from the remainder of the power system.

There are many researches about fault detections [1-60]. Some article presented in methods and also papers proposed in implementation. Several articles used artificial intelligent such as neural network, fuzzy logic, or genetic algorithm for fault detection. Also, many author used wavelet transform for detection. All of paper will be discussed inside the paper.

This article examines researches in the form of an article from the famous database. By drawing on the principles, implementation, and method is summarized. The future researcher have led it to utilize this advantage of brief. The content will focus on a summary of the key and effect of the method used.

The rest of this paper is organized: Section II presents the fault theory. Section III proposes fault detection classification; and the last section IV is the summary.

## 2. FAULT THEORY AND REVIEW ARTICLES

This section present the electricity power system structure, fault theory, and the article reviews. It is referred from many researches and source theories which are significant for the researcher for study in fault located identify as followed below:

### 2.1. Electricity power system

The electricity power system can be classified into generation, transmission, and generation. Generation is used for built the electricity current or voltage from a power plant. Also it is send to a power transmission line after increasing voltage to derived values. The transmission line system carries the electricity quantities that are the power value from generating centres to the load area. Before load center, the voltage is stepped down to normal value for each customer sector such as industrial sector, commercial sector, and other sectors.

There are different voltage values in each area, for instance in Thailand used 380/220 V 50 Hz for distribution system to customer. Thus, the fault may occur in power system from the generating system to customer. The short circuit in power system may effect to a wider power outage. Therefore, we need to diagnose the occurred fault and to identify the location fast. To the time of the short circuit in the electrical system is minimal. The fault types and case of fault in the power system have explained in the next section.

### 2.2. Fault types

Different types of faults can be classified into several types. Some major faults are phase fault such as phase to ground fault, phase to phase fault, phase-phase to ground fault, three phase fault. Other faults of electricity are of not major important. But they still are considered for the power system operation. They are open circuit faults, inter turn fault, and other faults.

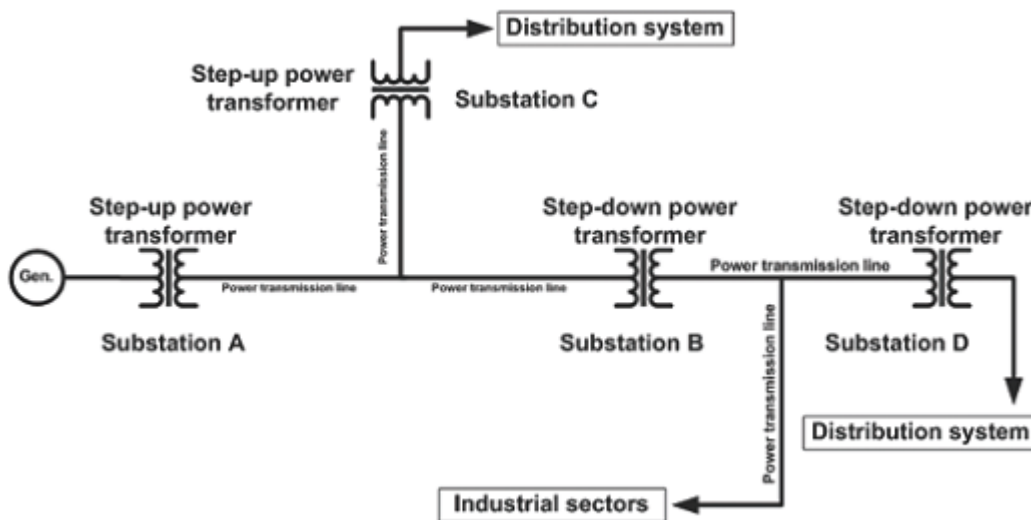

Figure 1. Power system structure.

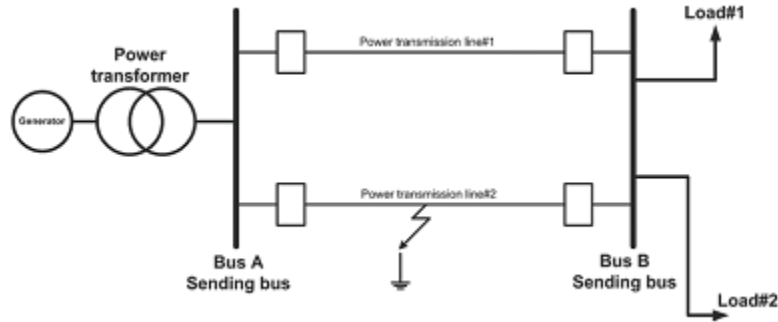

Figure 2. Fault occurs in transmission line.

Figure 1 illustrates the example of the fault occurred in power transmission line. There are several types of faults in transmission line for instance single phase to ground fault, double phase to ground fault, double phase fault, and three phase fault. In the case it has the fault locator for identifying locator that is distance relay and other auxiliary devices.

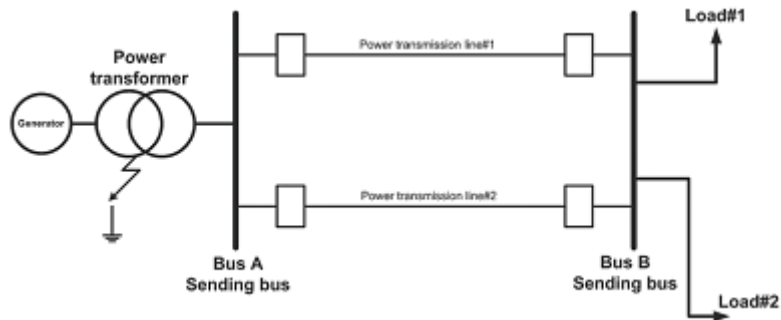

Figure 3. Fault occurs in transformer.

Figure 2 shows the fault occurred in power transformer. In the power system, there are four main types of transformer fault. These are arcing or high current breakdown, low energy sparking or partial discharges, localized overheating or hotspots, and general overheating due to inadequate or sustained overloading. The techniques for finding transformer faults are Buchholz relays safety device, dissolved gas analysis, and tests to detect oil contaminants and oil quality.

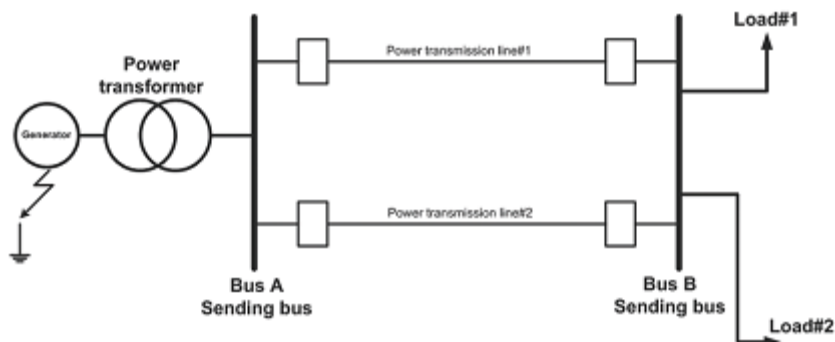

Figure 4. Fault occurs in machine or generator.

Figure 3 presents machine such as power generator fault. The major faults in power generator case can be classified into several cases. These are fail of prime movers, failure of excitation, and failure of

insulation in stator or interconnecting cable (inter phase short circuit, single phase to ground fault, inter turn faults, and ground fault on rotor). The fault in power generator can be switch off but for an automatic operation an under current relay in conjunction with time lagged tripping and time lagged reinforcing relay.

Therefore, fault identification is necessary for power system protection and selection of suitable relays, which are required for the subsequent fault isolation. The fault location techniques are used for electricity power system protection and also identify the fault position. The characteristics of fault locator are considered from fast system for repairing and restoring the power system normally. They improves the system availability and performance etc.,. The fault locator approaches and classification of faults will be discussed in the section of review articles. All of these case faults are for example of cases in power system which there are many case of faults occurred in the system.

### 2.3. Review Articles

For this section we will propose the past of articles presented in case of each method for fault diagnosis in power system. This section will explain all papers shortly and summary them in fault types or identification methods. The research on the practical detection for a power cable fault point by Dong Aihua and team in 2010 proposed case study in underground coal mine [1]. This paper presented the circuit diagram, which can quickly and accurately detect fault points of single-phase open circuit, two-phase short-circuit, single-phase grounding. This work the authors designed power cable fault detection circuits by using bridge method. The articles [2] [3] by alarm MN and team research and team searches proposed the design and application of surface wave exciters and sensors for fault detection, communication,

Table 1. Each case of fault proposed in articles

Articles proposed	Presented the fault case in power system
[1] [12] [14] [15] [16] [35] [36] [39] [41] [43] [45] [46] [47] [50] [57] [58]	Line fault (L-L,L-L-L,L-G,3L-G)
[8] [18] [19] [42] [48] [56]	Transformer fault
[26]	Insulation fault
[20] [24]	Machine fault
[23]	HVDC converter fault
[17] [31] [54] [59]	Feeder bus fault
[27] [60]	Under ground cable fault
[28] [49]	Nuclear system fault

and non-intrusive power line fault detection. Next research in paper [4] presented the observer-based fault detection and identification scheme for power systems. The results of detailed simulation studied involving disturbances and faults occurring in linear and non linear models of the system. In year 2010 the symmetrical pattern and PCA based frame work for fault detection and classification by Qais alsafasfeh and team researchers proposed in applied mathematics and signal processing developed the techniques for the detection and classification [5]. The article in fault detection by A. Ashouri et al. Presented a new approach that is the fault detection in digital relays-based power system using Petri Nets [6]. In this research, Petri nets have been used for modelling and location detection of faults and the proposed approach provided hierarchical monitoring of power system. The results of fault detection by Petri nets, the processing time of information is reduced and the precise of fault detection procedure is increased. The last oldest article in 1994, J. Narros and J.M. Drake showed real time fault detection and classification by using microprocessors [7] based on the estimation of the three phase voltage phasors by maen of a set of Kalman filters, and on the calculation of the fault probability. After that in year 2004, wavelet transform was proposed in fault detection in transformer by measurement of neural currents. The wavelet transform analysed based on Morlet wavelet (mother wavelet). The sensitivity of fault detection can be significantly improved by using wavelet analysis techniques for the evaluation of impulse tests on transformer. The approach [8] was presented by A. Bhoomaiah et al. The article of S. Bracho and M. Martinez presented about fault detection by using dynamic power supply current test in 1997 [9]. In next year, 1998, Fahmida N. Chawdhury and team researchers showed the detection of fault by using a modular methodology for fault detection and classification in power system. The approach is quite flexible. After a detection, the fault indicator is processed by a Kohonen network to classify the fault. These are the simple of articles for fault detection in the power system. Next, we will conclude these article in two cases for understanding for finding a now method in the future.

### 3. FAULT DETECTION CLASSIFICATION

The section of fault detection classification will be discussed about fault into case of fault, types of approaches and accuracy in power system as followed:

#### 3.1. Case of Fault

Case of fault, there are many cases of faults in power system explained the previous section. Also, it has explain in table for understanding clearly.

Table I shows each case of fault proposed in several articles. It explains fault types by each author published in any database. The authors may interest fault more than a fault. The studied fault quite covered fault in power system and also covered high voltage direct current (HVDC) system. From the table we observed the articles that study transmission line fault more than other faults.

#### 3.2. Types of Approaches

There are many approaches proposed in fault identify in the power system. They will illustrate from the Table II. These methods can help the operator for finding the short circuit location and analysing types of fault in the system.

Table II explains each approach to power system fault detection in several articles. These approaches use different mathematics equations but they can be used for identifying fault in the system similarly.

Table 2. Each approach to power system fault detection

Articles proposed	Presented the fault detected approaching power system
[1]	Bridge circuit method
[2] [3]	Surface wave
[6]	Petri nets
[8] [12] [17] [27] [37] [45] [48] [55]	Wavelet transform approach
[18] [19] [20] [31] [42] [47]	Neural network approach
[52]	Artificial intelligence (Fuzzy, Genetic)
[13]	Graph methodology
[14]	Real-time
[15] [42] [47]	Statistical methodology

Some papers presented an accuracy of each approach of fault detection in several articles. There are many things to consider in the protection design of each method. One of them is accurate. This could mean that the accuracy of the location and the type of short circuit or fault, it may be so. The example of accuracy of fault locator or classification will be shown in several articles.

Inconclude, many authors showed many cases of fault covered the system. The authors may be used the research for searching a new method for identifying the fault location or distance of fault in the power system.

### 4. SUMMARY

Fault detection in power system will be detected by many approaches. It can be seen in the previous section. The fault detection in system must fast when fault occurred in the transmission line, transformer, or any where in the electricity system. This paper proposes all of detection approaches used in the last and the present. Also, it can be used for one part of articles for developing their researches. However, this article only searches the paper in fault detection till 2014.

### ACKNOWLEDGEMENTS

I am very grateful for the helpful suggestions who are Assoc. Prof. Dr. Chusak Limsakul and Assis. Prof. Dr. Kusumal Chalermyanont, Prince of Songkla University.

### REFERENCES

- [1] Dong Aihua, Li Liang, Huo Liuhan, and Wang Qingxuan. "Research on the practical detection for a power cable fault point". *International Conference On Computer and Communication Technologies in Agriculture Engineering*. 2010; 2: 80-84.

- [2] MN Alam, RH Bhuiyan, R Dougal, and M Ali. "Novel surface wave exciters for power line fault detection and communications". *2011 IEEE International Symposium on Antennas and Propagation (APSURSI)*. 2011: 1139-1142.
- [3] MN Alam, RH Bhuiyan, RA Dougal, and M Ali. "Design and application of surface wave sensors for non-intrusive power line fault detection". *IEEE Transactions on sensor*. 2013; 13(1): 339-347.
- [4] M Aldeen and F Crusca. "Observer-based fault detection and identification scheme for power systems". IEE proceeding generation, transmission, and distribution. 2006; 153(1): 71-79.
- [5] Q Alsafasfeh, I Abdel-Qader, and A Harb. "Symmetrical pattern and PCA based framework for fault detection and classification in power systems". *IEEE International Conference on Electro/Information Technology (EIT)*. 2010: 1-5.
- [6] A Ashouri, A Jalilvand, R Noroozian, and A Bagheri. "A new approach for fault detection in digital relays-based power system using petri nets". Joint International Conference on Power Electronics, Drives and Energy Systems (PEDES). 2010: 1-8.
- [7] J Barros and JM Drake. "Realtime fault detection and classification in power systems using microprocessors". *Cation scheme for power systems*". IEE proceeding generation, transmission, and distribution, 1994; 141(4): 315-322.
- [8] A Bhoomaiah, PK Reddy, KSL Murthy, PA Naidu, and B Singh. "Measurement of neutral currents in a power transformer and fault detection using wavelet techniques". *Annual Report Conference on Electrical Insulation and Dielectric Phenomena*. 2004: 170-173.
- [9] S Bracho and M Martinez. "Catastrophic and parametric fault detection by dynamic power supply current test". *IEE Colloquium on Testing Mixed Signal Circuits and Systems*. 1997: 10/1-10/6.
- [10] FN Chowdhury and JL Aravena. "A modular methodology for fast fault detection and classification in power systems". *IEEE Transactions on control systems technology*. 1998; 6(5): 623-634.
- [11] X Ding, J Poon, I Celanovic, and AD Dominguez-Garcia. "Fault detection and isolation filters for three-phase AC-DC power electronics systems". *IEEE Transactions on circuits and systems*. 2013; 60(4): 1038-1051.
- [12] R Dubey, SR Samantaray, A Tripathy, BC Babu, and M Ehtesham "Wavelet based energy function for symmetrical fault detection during power swing". *Students Conference on Engineering and Systems (SCES)*. 2012: 1-6.
- [13] D Dustegor, SV Poroseva, MY Hussaini, and S Woodruff. "Automated graph-based methodology for fault detection and location in power systems". *IEEE Transactions on power delivery*. 2010; 25(2): 638-646.
- [14] J Ghorbani, MA Choudhry, and A Feliachi. "Real-time multi agent system modeling for fault detection in power distribution systems". *North American Power Symposium (NAPS)*. 2012; 1-6.
- [15] DM Gilbert and IF Morrison. "A statistical method for the detection of power system faults". *International Journal of Electrical Power and Energy Systems*. 1997; 19(4): 269-275.
- [16] L Han, R Menzies, JF Peters, and L Crowe. "High voltage power fault-detection and analysis system: design and implementation". *IEEE Canadian Conference on Electrical and Computer Engineering*. 1999; 3: 1253-1258.
- [17] Shu Hongchun, Wang Xu, Tian Xincui, Wu Qianjin, and Peng Shixin. "On the use of s-transform for fault feeder detection based on two phase currents in distribution power systems". *2<sup>nd</sup> International Conference on Industrial and Information Systems (IIS)*. 2010; 2: 282-287.
- [18] YC Huang, HT Yang, and KY Huang. "Abductive network model based diagnosis system for power transformer incipient fault detection". IEE proceeding generation, transmission, and distribution. 2002; 149(3) 326-330.
- [19] Yann-Chang Huang. "Power transformer fault detection using intelligent neural networks". *IEEE Region 10 Conference on Computers, Communications, Control and Power Engineering*. 2002; 3: 1761-1764.
- [20] KLV Iyer, Xiaomin Lu, K Mukherjee, and NC Kar. "Fault detection in copper-rotor SEIG system using artificial neural network for distributed wind power generation". *International Conference on Electrical Machines (ICEM)*. 2012: 1700-1705.
- [21] Zhu Jie-zhong, Yao Yong-lei, and Chen Su-ting. "Proposal for the software development of a radar power fault detection system". *Physics Procedia*. 2012; 33: 877-883.
- [22] Dae-Yi Jung and RR Selmic. "Power leader fault detection in non linear leader-follower networks". *IEEE Conference on Decision and Control*. 2008; 404-409.
- [23] S Karimi, P Poure, and S Saadate. "Fast power switch failure detection for fault tolerant voltage source inverters using FPGA". *IET power electronics*. 2009; 2(4): 346-354.
- [24] H Khan, Seraphin C Abou, and N Sepehri. "Non linear observer-based fault detection technique for electro-hydraulic servo-positioning systems". *Mechatronics*. 2005; 15(9): 1037-1059.
- [25] Zhenghua Li. "Hilbert-huang transform based application in power system fault detection". International Workshop on Intelligent Systems and Applications. 2009: 1-4.
- [26] Yow-Chyi Liu and Chen-You Lin. "Insulation fault detection circuit for ungrounded DC power supply systems". *IEEE Sensors*. 2012: 1-4.
- [27] Zhiling Long, NH Younan, and TO Bialek. "Underground power cable fault detection using complex wavelet analysis". *International Conference on High Voltage Engineering and Application (ICHVE)*. 2012: 59-62.
- [28] Jianping Ma and Jin Jiang. "Applications of fault detection and diagnosis methods in nuclear power plants: A review". *Progress in Nuclear Energy*. 2011; 53(3): 255-266.
- [29] Joaquim Melndez, Oscar Quiroga, and Sergio Herraiz. "Analysis of sequences of events for the characterization of faults in power systems". *Electric Power Systems Research*. 2012; 87: 22-30.

- [30] P Mohajerin Esfahani, M Vrakopoulou, G Andersson, and J Lygeros. "A tractable non linear fault detection and isolation technique with application to the cyber-physical security of power systems". *IEEE Annual Conference on Decision and Control (CDC)*. 2012: 3433-3438.
- [31] EA Mohamed and ND Rao. "Artificial neural network based fault diagnostic system for electric power distribution feeders". *Electric Power Systems Research*. 1995; 35(1): 1-10.
- [32] JA Momoh and AS Ishola-Salawu. "A new arcing fault modeling and detection technique for navy IPS power system". *IEEE Power Engineering Society General Meeting*, 2006.
- [33] M Mozaffari-Kermani and A Reyhani-Masoleh. "A low-power high performance concurrent fault detection approach for the composite fields-box and inverses-box". *IEEE Transactions on computers*. 2011; 60(9): 1327-1340.
- [34] A Muoz and MA Sanz-Bobi. "An incipient fault detection system based on the probabilistic radial basis function network: Application to the diagnosis of the condenser of a coal power plant". *Neuro computing*. 1998; 23(13): 177-194.
- [35] K Nareshkumar, MA Choudhry, J Lai, and A Feliachi. "Application of multi-agents for fault detection and reconfiguration of power distribution systems". *IEEE Power Energy Society General Meeting*. 2009: 1-8.
- [36] PK Nayak, AK Pradhan, and P Bajpai. "A fault detection technique for the series-compensated line during power swing". *IEEE Transactions on power delivery*. 2013; 28(2): 714-722.
- [37] ID Nicolae, PM Nicolae, and LD Popa. "Abilities of a class of wavelet hybrid algorithms related to fault detection in power systems". *International Conference on Applied and Theoretical Electricity (ICATE)*. 2012: 1-6.
- [38] M Ohrstrom and L Soder. "Fast protection of strong power systems with fault current limiters and PLL-Aided fault detection". *IEEE Transactions on power delivery*. 2011; 26(3): 1538-1544.
- [39] MF Othman, M Mahfouf, and DA Linkens "Transmission lines fault detection, classification and location using an intelligent power system stabiliser". *2004 IEEE International Conference on Electric Utility Deregulation, Restructuring and Power Technologies*. 2004; 1: 360-365.
- [40] JG Rao and AK Pradhan. "Application of synchrophasor data for fault detection during powers wing". *International Conference on Energy, Automation, and Signal (ICEAS)*. 2011: 1-5.
- [41] JG Rao and AK Pradhan. "Differential power-based symmetrical fault detection during power swing". *IEEE Transactions on power delivery*. 2012; 27(3): 1557-1564.
- [42] G Rigatos, P Siano, and A Piccolo. "Incipient fault detection for electric power transformers using neural modeling and the local statistical approach to fault diagnosis". *IEEE Sensors Applications Symposium (SAS)*. 2012: 1-6.
- [43] S Saha, M Aldeen, and CP Tan. "Fault detection in transmission networks of power systems". *International Journal of Electrical Power and Energy Systems*. 2011; 33(4): 887-900.
- [44] SR Samantaray, RK Dubey, LN Tripathy, and BC Babu. "Spectral energy function for fault detection during power swing". *International Conference on Energy, Automation, and Signal (ICEAS)*. 2011: 1-6.
- [45] SR Samantaray, KB Panigrahi, and PK Dash. "High impedance fault detection in power distribution networks using time-frequency transform and probabilistic neural network". *IET generation, transmission, and distribution*. 2008; 2(2): 261-270.
- [46] SR Samantaray. "Ensemble decision trees for high impedance fault detection in power distribution network". *International Journal of Electrical Power and Energy Systems*. 2012; 43(1): 1048-1055.
- [47] SR Samantaray, PK Dash, and SK Upadhyay. "Adaptive kalman filter and neural network based high impedance fault detection in power distribution networks". *International Journal of Electrical Power and Energy Systems*. 2009; 31(4): 167-172.
- [48] L Satish. "Short-time fourier and wavelet transforms for fault detection in power transformers during impulse tests". *IEE proceeding science, measurement, and technology*. 1998; 145(2): 77-84.
- [49] MD Shah. "Fault detection and diagnosis in nuclear power plant; a brief introduction". *Nirma University International Conference on Engineering (NUiCONE)*. 2011: 1-5.
- [50] AM Sharaf, RM El-Sharkawy, HEA Talaat, and MAL Badr. "Fault detection on radial and meshed transmission systems using fast hilbert transform". *Electric Power Systems Research*. 1997; 41(3): 185-190.
- [51] AK Singh and SK Parida. "A multiple strategic evaluation for fault detection in electrical power system". *International Journal of Electrical Power and Energy Systems*. 2013; 48: 21-30.
- [52] Dipti Srinivasan, Ruey Long Cheu, Young Peng Poh, and Albert Kim Chwee Ng. "Automated fault detection in power distribution networks using a hybrid fuzzy genetic algorithm approach". *Engineering Applications of Artificial Intelligence*. 2000; 13(4): 407-418.
- [53] Abhisek Ukil and Rastko Ivanovi. "The detection of abrupt changes using recursive identification for power system fault analysis". *Electric Power Systems Research*. 2007; 77(34): 259-265.
- [54] Zeng Xiangjun, KK Li, WL Chan, and Su Sheng. "Grounding faulted feeder detection with fault resistance measurement in mining power systems". *Industry Applications Conference*. 2005; 1: 657-661.
- [55] Yang Xiaohua, Zhang Yadong, China Zhao Faqi, and Xi Zhongmei. "Wavelet neural network based fault detection method in power system". *2011 Second International Conference on Mechanic Automation and Control Engineering (MACE)*. 2011: 1864-1867.
- [56] N Yadaiah and N Ravi. "Fault detection techniques for power transformers". *Industrial Commercial Power Systems Technical Conference*. 2007: 1-9.
- [57] Zhang Yagang, Zhang Jinfang, Ma Jing, and Wang Zengping. "Fault detection and identification based on DFS in electric power network". *IEEE International Symposium on Knowledge Acquisition and Modeling Workshop*. 2008: 742-745.

- [58] AA Yusuff, AA Jimoh, and JL Munda. "Determinant-based feature extraction for fault detection and classification for power transmission lines". *IET generation, transmission, and distribution*. 2011; 5(12): 1259-1267.
- [59] Xiangjun Zeng, KK Li, WL Chan, Sheng Su, and Yuanyuan Wang. "Ground-fault feeder detection with fault-current and fault-resistance measurement in mine power systems". *IEEE Transactions on Industry applications*. 2008; 44(2): 424-429.
- [60] W Zhao, YH Song, and Y Min. "Wavelet analysis based scheme for fault detection and classification in underground power cable systems". *Electric Power Systems Research*. 2000; 53(1): 23-30.

### BIOGRAPHY OF AUTHOR



Dr. Pituk Bunnoon received the B.S. degree from King Mongkut's Institute of Technology Ladkrabang, Thailand, in 1998, and the M.S. degree and Ph.D. degree in electrical engineering from Prince of Songkla University, Thailand, in 2004 and 2013, respectively. His research interest is an application of artificial intelligence to power system planning and operation. For the present, he works at Rajamangala University of Technology Srivijaya, Thailand in Electrical engineering department, faculty of engineering. He is the member IEEE.