

Intelligent Pillow for Heart Rate Monitor

Everlyn Chiang Hai Yin, V. Muthukumar

Faculty of Engineering and Computer Technology, AIMST University

Article Info

Article history:

Received Jul 21, 2013

Revised Oct 11, 2013

Accepted Oct 30, 2013

Keyword:

Fiber optical sensor

IR LED

Light

Photodiode

Photoplethysmogram

PPG

ABSTRACT

The aim of the project is to develop intelligent pillow to monitor the heart rate by using fiber optical sensor. The research is focused upon allowing more automation of patient care, an especially important matter for the elder population or bedridden patients, which is a rapidly growing fraction of much of the world population today. The fiber-optical sensor is built into pillow. Patients can determine their heart rate by just lying on the pillow and the device will not cause any disturbance to patients and at the same time still monitoring the heart rate. ECG electrodes and finger clip / ear lobe clip probes (using IR LED and photodiode technology) are commonly used for monitoring heart rate. Unfortunately, they are inconvenient and inadequate for long-term, everyday measurements. Fiber-optical sensing overcomes many of these challenges by using light rather than electricity and standard optical fiber in place of copper wire. Optical fibers are nonconductive, electrically passive, immune to electromagnetic interference (EMI)-induced noise, and able to transmit data over long distances with little or no loss in signal integrity. Using the concept of light and the benefits of using fiber optical sensors to detect the heart rate, PPG (photoplethysmogram) is being used in this project. A photoplethysmogram (PPG) is an optically obtained plethysmogram, a volumetric measurement of an organ. A PPG is often obtained by using a pulse oximeter which illuminates the skin and measures changes in light absorption.

*Copyright © 2013 Institute of Advanced Engineering and Science.
All rights reserved.*

Corresponding Author:

Everlyn Chiang Hai Yin

Faculty of Engineering and Computer Technology

AIMST University

3 Jalan Seroja 1/1, Taman Seroja, 08000 Sungai Petani, Kedah, Malaysia

e-mail: rbychiang@gmail.com

1. INTRODUCTION

ECG electrodes and pulse oximeter (using finger clips) are being used for heart rate monitoring today and unfortunately, they are inconvenient and inadequate for long-term, everyday measurements. They are not encouraged to be implemented under bed or pillows as dangerous electric shock might hurt the patients easily. By considering the advantages of using fiber-optical sensors, it is well suited to be implemented under the pillow to detect human's heart rate. The goal of the project:

- 1) To design small, simple and safe fiber optic sensor and heart rate system to be implemented under the pillow.
- 2) To design low powered heart rate that will provide an accurate reading of one's heart rate.
- 3) To design an operating system of the project. To develop the control system that will receive the input signal for determine the process that it must execute to give out the desired output.

General principle of fiber optical PPG sensors is that light from a laser (often a single-frequency fiber laser) or from a super luminescent source is sent through an optical fiber, experiences subtle changes of its parameters either in the fiber or in one or several fiber Bragg gratings, and then reaches a detector arrangement which measures these changes.

PPG (photoplethysmography) can be done in two methods: transmittance and reflectance of light. In transmittance, the light is shone through the tissue using an infrared LED and is detected on the other end using a photodetector/phototransistor. In contrast, in reflectance method, both infrared LED and photodetector/phototransistor are allocated at the same side to detect the light reflected by the tissue.

2. RESEARCH METHOD

Fiber optic cables are commonly expensive and the project does not need to use fiber optic cables with high qualities. Fiber optic cables with multi-mode and step-index is sufficient enough in this project. The wavelength of the infrared is 950nm. Infrared light which is in the 850-1000 nm wavelength light band is found to be most widely researched for this application. Reflection configuration is selected compared to transmission configuration as it can detect any area of human skin as it only uses the concept of reflection of light which reflects from the surface of the human skin.

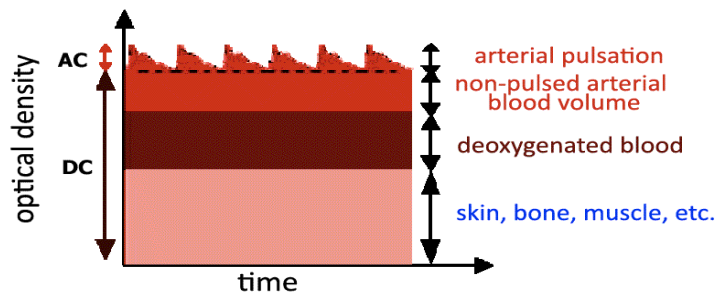

Figure 1. AC and DC components of fiber optic PPG

Both arterial blood volumetric changes and venous blood volume changes are considered as the AC component, so fiber optic PPG consists of two components: AC component and DC component. Unfortunately, AC component is relatively weaker compared to DC component. Before light reaches the phototransistor, it needs to pass through various tissue constituents such as skin, bone muscle etc resulting in a constant DC offset to the signal. Optical density is the measure of the transmission of an optical medium for a given wavelength. AC component of the fiber optic PPG signals is the only component required to measure the heart beat, so DC component of the signal needs to be filtered out completely and then the AC component of the signal must be amplified until a sufficient voltage level. Once the PPG signals are acquired after filtering and amplifying, each peak of the voltage signal will act as a DC input to the microcontroller for software running. Filtering and amplifying using high pass filter and active low pass filter.

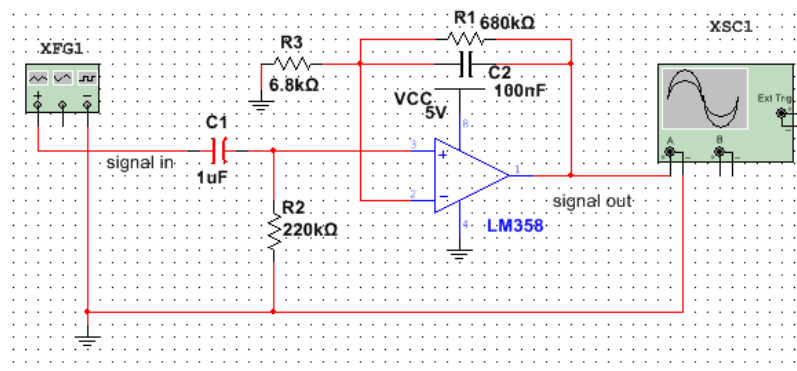

Figure 2. Passive high pass filter and active low pass filter

In order to solve the possible interruption to the fiber optical sensors, an effort of securing the fiber optical cables is needed. Longer fiber optical cables might cause more disturbances, so by using shorter fiber

optic cables, it will limit the amount of noises to the signals. Both the surface of the fiber optic probe have to be equally aligned for better sensing. A precision drilled wooden piece was made for experiment purpose.

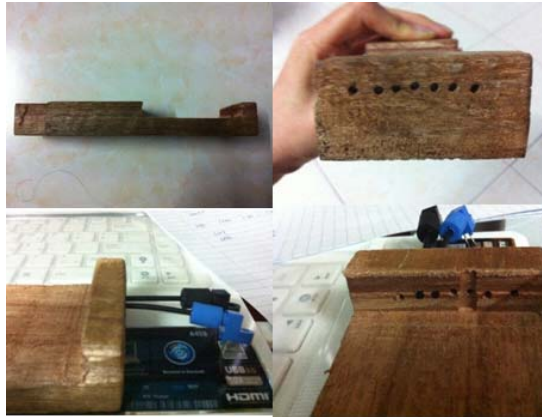

Figure 3. A precision drilled wooden piece for experiment purpose

Providing comfort to consumers was taken as priority while implementing the boards under the pillow.



Figure 4. Intelligent pillow



Figure 5. Position of fiber optic sensor

This pillow was temporarily used as a prototype only as this project was not concentrating on the design of the physical look of the pillow. The current sensor's position was sufficient to detect the heart rate from sensor, but due to its fixed position, different sleeping postures might affect the measurement of heart rate. For future improvement, external accessory can be included to connect with the sensor to provide flexibility, which acts like a sticker and can be attached to any areas according to the consumer's preference.

3. RESULTS AND ANALYSIS

This project was based on test-driven design procedures. Though the methodology of the solution was conceptually designed, the practical implementation involved testing and improving each of the stages as part of its progress. Various testing procedures were part of the project even from the first phase, such as when the phototransistor was tested for its sensitivity. Other testing procedures included comparison of active and passive filters. Other procedures such as longevity and stress tests were also executed on the final completed circuit in order to ensure its safety and reliability. The data collected was subsequently processed by the software component of this project and the results were compared with those of the commercial heart rate monitor.

Fiber optic PPG signals acquired after testing:



Figure 6. Fiber optic PPG signals 1



Figure 7. Fiber optic PPG signals 2

The dicrotic notch of the PPG signals is clearly visible, in addition to other details such as sharply rising systolic peak and slowly settling diastolic foot. Different individuals will display different shapes of PPG signals but the concept of the signals is still the same.

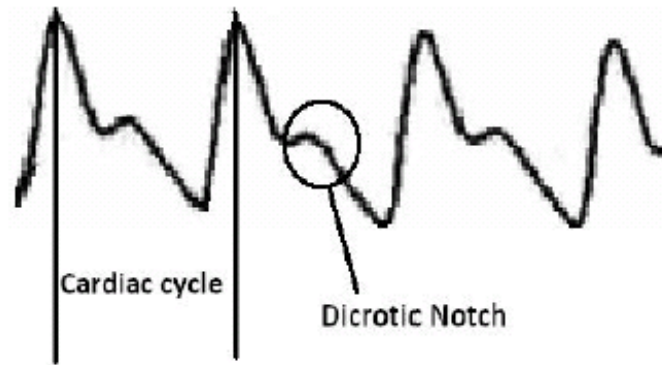

Figure 8. PPG signals from commercial heart rate monitor 1

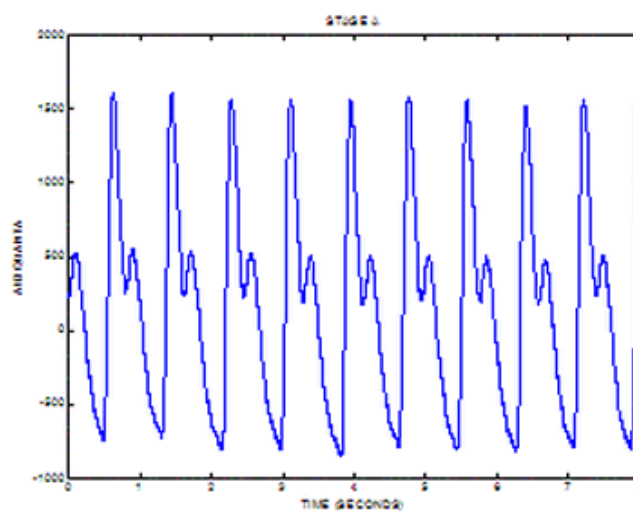

Figure 9. PPG signals from commercial heart rate monitor 2

Results are compatible with other PPG signals from current available heart rate monitor.

4. CONCLUSION

The numerous challenges encountered during this time only improved the design procedures and can be seen as necessary catalysts. The biometrics of heart rate produced by this intelligent pillow is important additions to those bedridden patients and for great convenience to serve as significant indicators of the health of the individual. Although the accuracy of the measurements may not be as accurate as ECG or advanced pulse oximeters, they are still very close to the actual results and can be used in trend analysis if not in clinical diagnosis. The strength of this project lies in the portability and comfortability to the consumers who are concern about their heart rate at all times including when they sleep.

If given more time to work on this project, the project could be further improved in various ways. Fiber optic sensors in the intelligent pillow can be used to detect blood oxygen saturation or blood pressure and not only the heart rate. The throughput of the TCP/IP server or wireless system can be implemented to allow for richer parallel data acquisition by remote clients.

In conclusion, the project can be further improved in various ways that can make it more user-friendly and accurate for better market value. It can become a good accessory to the user in tracking their health and the health of the ones they are concerned about. It can also become a good addition to the automated infrastructures already in place in hospitals.

ACKNOWLEDGEMENTS

Financial support for this study was provided by Faculty of Engineering and Computer Technology from AIMST University. The authors wish to thank Advisor Prof. Ernest Teiko Larmie, Faculty of Medicine, whose being very supportive, giving stimulating suggestions and encouragement.

REFERENCES

- [1] Optical Fibre Sensors Embedded into technical Textile for Healthcare, "Optical fibre sensors for medical applications".
- [2] Venu Gopal Madhav Annamdas 1,2. "Review on Developments in Fiber Optical Sensors and Applications". *International Journal of Materials Engineering*. 2011; 1(1): 1-16.
- [3] WB Spillman Jr 1,2, M Mayer 1, J Bennett 1, J Gong 1, KE Meissner 1, B Davis 1, RO Claus 1, AA Muelenaer Jr 1 and X Xu1. "A 'smart' bed for non-intrusive monitoring of patient physiological factors". Received 24 December 2003, in final form 24 February 2004, Published 19 July 2004
- [4] William Spillman, chair, Jimmy Ritter, Guy Indebetouw. "Dual Processing Spatially Distributed Integrating Fiber Optic Sensors for Non-intrusive Patient Monitoring". Blacksburg, Virginia. 2005.
- [5] John Allen. "Photoplethysmography and its application in clinical physiological measurement". Received 8 October 2006, accepted for publication 24 January 2007, Published 20 February 2007, Regional Medical Physics Department, Freeman Hospital, Newcastle upon Tyne NE7 7DN, UK
- [6] Janis Spigulis, Renars Erts, Vladimirs Nikiforovs and Edgars Kviesis-Kipge. "Wearable wireless photoplethysmography sensors". Bio-optics and Fiber Optics Laboratory, Institute of Atomic Physics and Spectroscopy University of Latvia, Raina Blvd. 19, Riga, LV-1586, Latvia.

BIOGRAPHIES OF AUTHORS



Everlyn Chiang Hai Yin is currently pursuing bachelors degree program in electrical & electronic engineering in Faculty of Engineering and Computer Technology, AIMST University, Malaysia.
E-mail: rbychiang@gmail.com



V. Muthukumar is currently working as a Senior Lecturer in Faculty of Engineering and Computer Technology, AIMST University, Malaysia.
His area of research interest is VLSI based image processing and Bio-MEMS.
He got 12 years of vast teaching experience.
E-mail: gymkumaran@gmail.com