

## Power System Stability Enhancement and Improvement of LVRT Capability of a DFIG Based Wind Power System by Using SMES and SFCL

Anju M<sup>1</sup>, R. Rajasekaran<sup>2</sup>

Department of EEE, SNS College of Technology, Coimbatore, India  
email: anju51011@gmail.com<sup>1</sup>, rare457@gmail.com<sup>2</sup>

---

### Article Info

#### Article history:

Received Jun 6, 2013  
Revised Jul 21, 2013  
Accepted Aug 2, 2013

#### Keyword:

DFIG  
Doubly fed induction generator  
Low voltage ride through  
LVRT  
SCFL  
SMES

---

### ABSTRACT

This paper proposes a exhaustive study about the performance analysis of Doubly Fed Induction (DFIG) under abnormal condition. Now a day, majority of power network countenance the problem of over current and grid connectivity issues. SFCL (Superconducting Fault Current Limiter), which have the competence to limit the fault current and protect the equipments from damage. SMES (Superconducting Magnetic Energy Storage) is mainly used to compensate both real and reactive power variations, thus power quality can be enhanced. Co-ordinated operation of SFCL - SMES thus used to enhance the power system stability and improve the LVRT (Low Voltage Ride Through) capability of wind power generation systems. LVRT capability of wind turbine is refers to the ability of wind power system to conquer the voltage variations if there is any unwanted conditions. Here DFIG based wind turbine plant is used for consideration, because it will provide smoothened power output nearly double than a conventional generator. And it have more simple and rugged construction also. Design of DFIG based wind power generation systems under fault condition with the help of SMES and SFCL is analysed by means of MATLAB/SIMULINK block set.

*Copyright © 2013 Institute of Advanced Engineering and Science.  
All rights reserved.*

---

### Corresponding Author:

Anju. M,  
Department of EEE, SNS College of Technology  
Coimbatore, India  
Email: anju51011@gmail.com

---

## 1. INTRODUCTION

In recent years more attention has been given to induction machines because they are used for low and medium power application. Attractive advantages over conventional generators are lower unit cost, less maintenance and robust construction etc. Doubly-Fed Induction Generators (DFIG) is particularly suitable for isolated operation like hydro and wind developments [1].

Doubly fed induction generators (DFIGs) are currently dominating the renewable energy market. Over the last decades, DFIG-based wind turbines have been most preferred option for the high capacity wind farms because it has the ability to control the active and reactive power exchange within the network. DFIGs have the capability to operate in variable speed regions so we have to achieve a smoothened and twice the power than any other conventional generator will produce. In the development of wind turbine techniques, DFIG is becoming more popular because of its unique characteristics such as high efficiency, low cost and flexible control [2].

Most of the wind turbines face a problem of LVRT. One common LVRT solution is to install a crowbar circuit across the rotor terminals. When the rotor over current is detected, the crowbar circuit short circuits the rotor terminals and isolates the converters from the rotor. And thus Rotor Side Converter

triggering is blocked. This provides conservative protection to the rotor circuit and the RSC changes the DFIG to a squirrel cage induction machine, which absorbs reactive power from the grid. As a result dynamic VAR compensators, such as static VAR compensators or static synchronous compensators are sometimes installed at the DFIG terminals to provide reactive power support during a grid fault [3].

Unbalanced grid faults degrade the performance of DFIG-based wind turbines. In fact, if voltage unbalance is not taken into account the stator and rotor currents will be highly unbalanced even with a small unbalanced stator voltage. The unbalanced currents will create unequal heating on stator and rotor windings which will produce a complete change in torque and power pulsations of the generator which is twice the line frequency [4].

Several control approaches have been presented for DFIG systems operating with unbalanced grid faults. The rotor-side system is decomposed in two separate models which are represented with positive and negative-sequence components respectively. Two parallel controllers which are expressed in the positive and negative-synchronous reference frame are also presented. The goal of the positive-sequence controller is to regulate the rotor side converter as in the case of normal operating conditions [5].

## 2. DFIG BASED WIND POWER GENERATION

The majority of wind turbines are equipped with Doubly Fed Induction Generators (DFIGs). The wound rotor induction generator has stator which is directly connected to the grid and rotor mains are done by a Variable Frequency AC/DC/AC Converter (VFC). This has the ability to handle a fraction (25%-30%) of the total power to achieve full control of the generator. The Variable Frequency Controller consists of a Rotor side Converter (RSC) and a Grid-Side Converter (GSC) connected back-to-back by a dc-link capacitor in order to meet power factor requirement (e.g.  $-0.95$  to  $0.95$ ) at the point of connection.

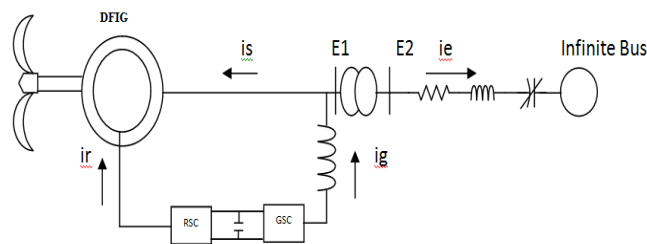

Figure 1. Wind turbine model

### 2.1. Controller Circuit of Rotor Side Converter (RSC)

The Rotor-Side Converter (RSC) applies the voltage to the rotor windings of the Doubly-Fed Induction Generator. The purpose of the rotor-side converter is to control the rotor currents such that the rotor flux position is optimally oriented with respect to the stator flux in order that the desired torque is developed at the shaft of the machine. The rotor-side converter uses a torque controller to regulate the wind turbine power output and measured the voltage or reactive power at the machine stator terminals. The power is measured in order to follow a pre-defined turbine power-speed characteristic to obtain the maximum power point.

In order to reduce the power error or rotor speed error to zero, a Proportional-Integral (PI) regulator is used at the outer control loop. The output of the regulator is the reference rotor current ' $i_{rqref}$ ' that must be injected in the rotor winding by rotor-side converter. This  $q$ -axis component controls the electromagnetic torque ' $Te$ '. The actual ' $i_{rq}$ ' component of rotor current is compared with ' $i_{rqref}$ ' and the error is minimized to zero by a current PI regulator at inner control loop. The output of this current controller loop is the voltage ' $v_{rq}$ ', which is generated by rotor-side converter with another similarly regulated ' $i_{rd}$ ' and ' $v_{rd}$ ' component so the required 3-phase voltages applied to the rotor winding are obtained.

To describe the control scheme, the general Park's model of an induction machine is introduced. Stator-oriented reference frame without saturation, the voltage vector equations are

$$V_s = i_s * R_s + d\alpha/dt \quad (1)$$

$$V_r = i_r * R_r + d\alpha/dt \quad (2)$$



**2.2. Controller circuit of Grid-Side Converter (GSC)**

The grid-side converter aims to regulate the voltage of the dc capacitor link. Moreover, it is allowed to generate or absorb reactive power for voltage support requirements. The function is realized with two internal control loops as well as an outer regulation loop. The reference current measured at the output of voltage regulator is  $i_{cdref}$  for the current regulator. The inner current regulator loop consists of a current regulator to control the magnitude and phase of the generated voltage of converter. The  $i_{cdref}$  is produced by the dc voltage regulator and specified  $q$ -axis  $i_{cqref}$  reference is shown in Figure 3.

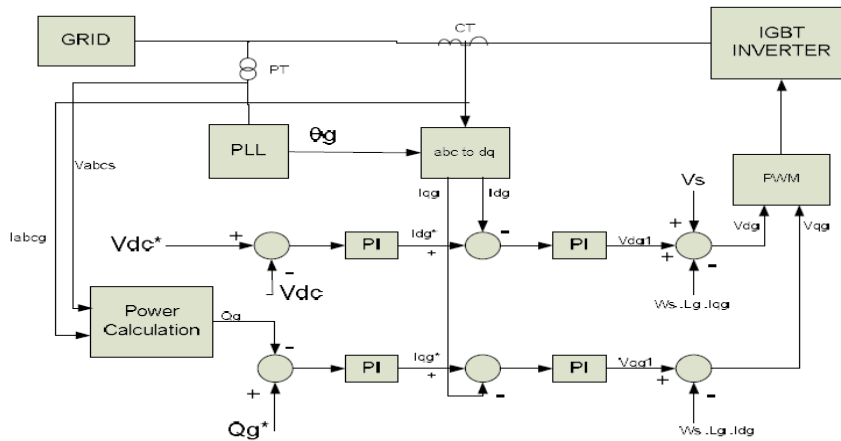

Figure 3. The Grid-Side Converter (GSC)

**3. SUPERCONDUCTING MAGNETIC ENERGY STORAGE (SMES)**

A SMES device is a dc current controlled device that have the ability to stores energy in the magnetic field. The dc current flowing through a superconducting coil in a large magnet creates the magnetic field. The inductively stored energy ( $E$  in Joule) and the rated power ( $P$  in Watt) are commonly given in specifications for SMES devices and they can be expressed as follows:

$$E = (1/2)LI^2 \tag{14}$$

$$P = dE/dt = LI di/dt = VI \tag{15}$$

where ' $L$ ' is the coil inductance, ' $I$ ' be the dc current flowing through the coil and ' $V$ ' is the voltage across the coil.

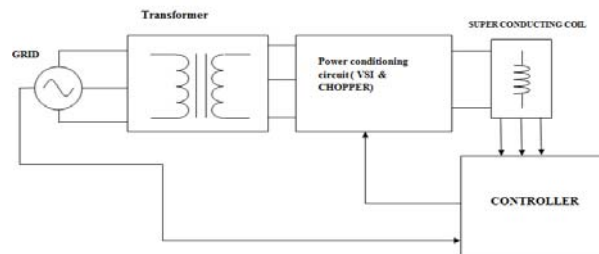

Figure 4. Components of a typical SMES system

A SMES system consists of a superconducting coil, cryogenic system and the power conversion or conditioning system (PCS) used for control and protection functions. SMES consists of

1. Power Conditioning System (PCS)
2. SMES Coil.

**3.1. Power Conditioning System**

The PCS provides a power electronic interface between the WTG and the Short circuit Coil which have to perform two goals: one is to convert electric power from dc to ac and the other is to charge/discharge the coil efficiently. The major component of the proposed PCS is the well-known three-phase voltage source inverter (VSI) or converter (VSC) shunt-connected to the distribution network by means of a step-up Δ–Y coupling transformer as depicted in Figure 5. The major component of a VSI is the Isolated Gate Bipolar Transistors (IGBTs). Due to its lower switching losses and reduced size when compared to other devices its operation have high priority. Output voltage control of the VSI can be efficiently achieved through sinusoidal pulse width modulation (SPWM) techniques. This three-level six-pulse VSI topology generates more smooth sinusoidal output voltage waveform than a conventional structure without increasing the switching frequency.

**3.2. SMES Coil**

An SMES system consists of several sub-systems which must be carefully designed in order to obtain a high-performance compensation device under the phenomenon of superconductivity. The base of the SMES unit is a large Superconducting Coil (SC), whose basic structure consisting of the cold components itself (the SC with its support connection components and the cryostat) and the cryogenic refrigerating system in Figure 5. The equivalent circuit of the SMES coil makes use of a lumped parameters network represented by a four-segment model comprising self inductances ( $L_i$ ), mutual couplings between segments ( $i$  and  $j$ ,  $M_{ij}$ ), ac loss resistances ( $R_p$ ), skin effect related resistances ( $R_{pi}$ ), turn-ground (shunt— $C_{shi}$ ), and turn–turn capacitances (series— $C_{Si}$ ) are shown in Figure 5.

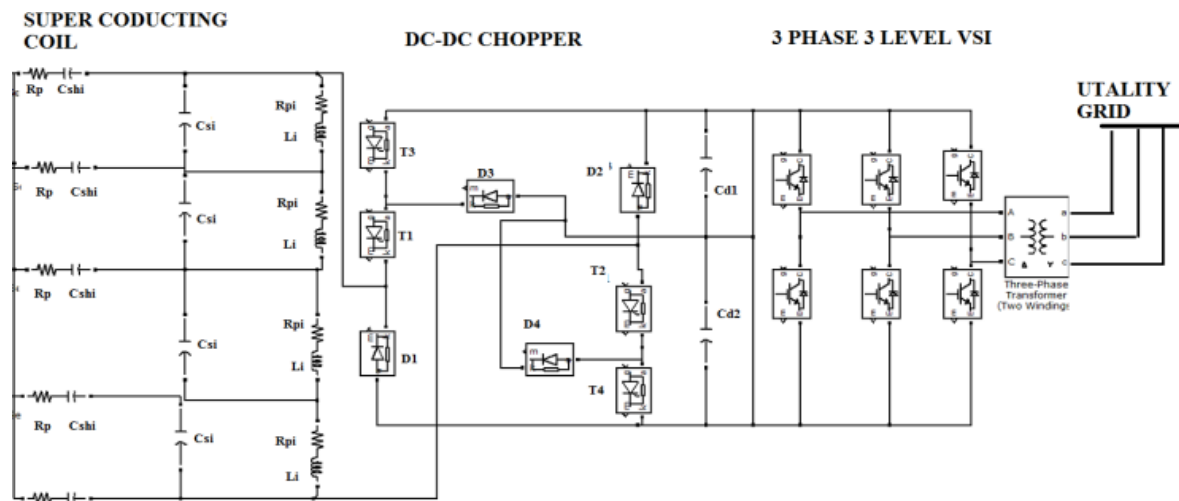

Figure 5. Detailed model of the proposed SMES system including the PCS and the SC.

**4. SUPERCONDUCTING FAULT CURRENT LIMITER (SFCL)**

SFCLs utilize superconducting materials to limit the current directly or to supply a DC bias current that affects the level of magnetization of a saturable iron core. While many FCL design concepts are being evaluated for commercial use and improvements in superconducting materials over the last 3 years have driven the technology to the forefront. This improvement is due to the ability of HTS materials to operate at temperatures around 70K instead of near 4K which is required by conventional superconductors. The advantage is that the refrigeration overhead associated with operating at the higher temperature is about 20 times less costly than the initial capital cost.

SFCLs use the transition of superconductors from zero to finite resistance to limit the fault currents that result from short circuits in electric power systems. Such short circuits can be caused by aged or accidentally damaged insulation by lightning striking an overhead line or by other unforeseen faults. If not deliberately checked, the subsequent fault current is limited only by the impedance of the system between the location of the fault and the power sources.

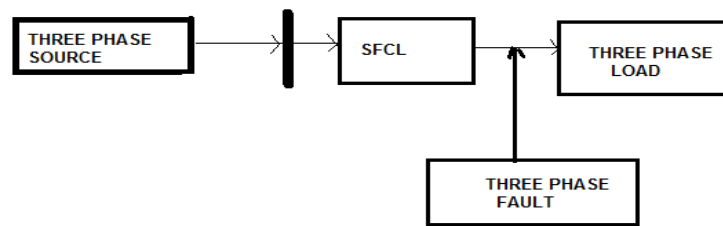

Figure 6. Superconducting Fault Current Limiter connected in series transmission line

## 5. RESULTS AND DISCUSSION

The fault-current limiting principle of the SFCL-MES is the same as that of the rectifier-bridge-type fault-current limiter. Under normal operation, the SC current is regulated to be higher than the peak amplitude of ' $n \cdot i_{sabc}$ ' or ' $n \cdot i_{rabc}$ ' when the SFCL-MES is connected on the stator side or rotor side respectively. Where  $i_{sabc}$ ,  $i_{rabc}$  are the stator and rotor current and ' $n$ ' be the isolation transformer turns ratio (stator or rotor side to the rectifier side) respectively.

During normal operation, the SC shows non inductive impedance and the forward voltage drop of the rectifier, the voltage drop of winding resistance and leakage inductance of isolation transformers are the only impedance of the circuit which are negligibly small. During a fault, when the fault current increases in amplitude and reaches the value of ' $i_{sc}/n$ ' ( $i_{sc}$  is the current of the SC). The SC will be inserted into stator or rotor circuit so increasing the fault circuit impedance and therefore limiting the fault current to a predetermined value.

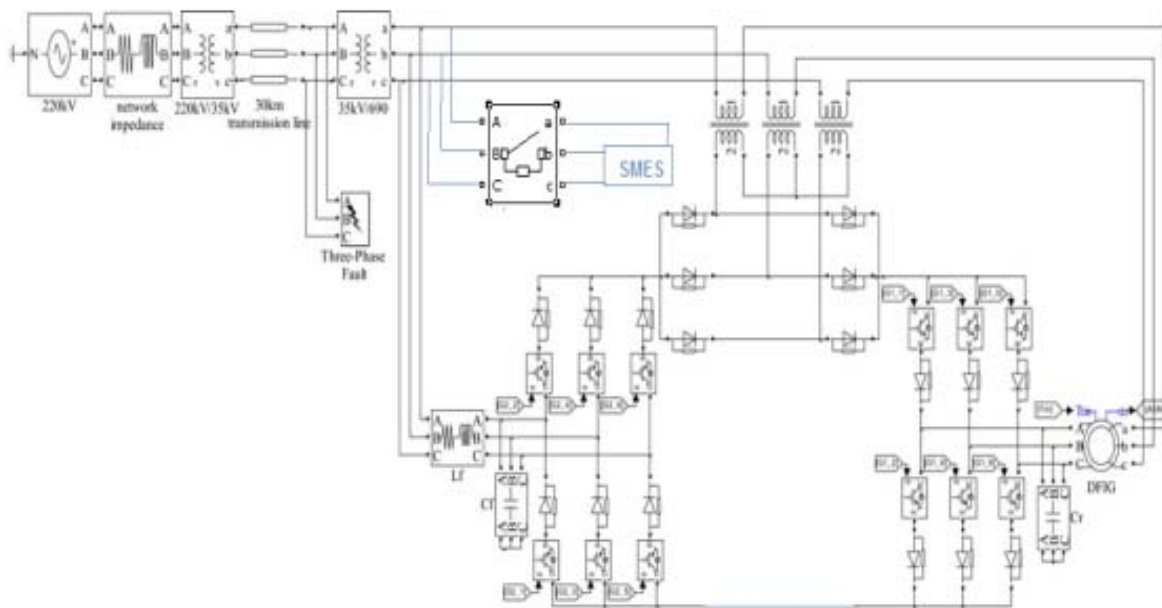

Figure 7. DFIG incorporated with the SFCL-MES (voltage source topology)

The DFIG current-source incorporated with the SFCL-MES is shown in Figure 7. The dc terminals of the GSC, diode rectifier and RSC are connected in series with a common dc-link capacitor. The ac terminal of the diode rectifier is connected in series with DFIG by three isolation transformers. Depending on the connection point of the isolation transformers the SFCL circuit can be connected in series with stator and SMES connected in parallel to stator

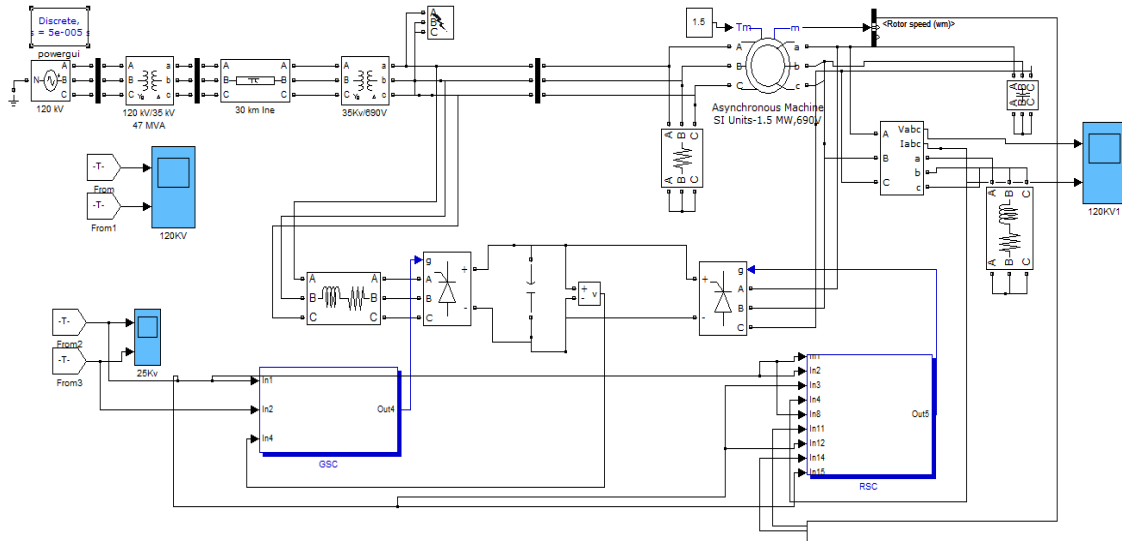

Figure 8. Modelling of DFIG based wind power generation under fault

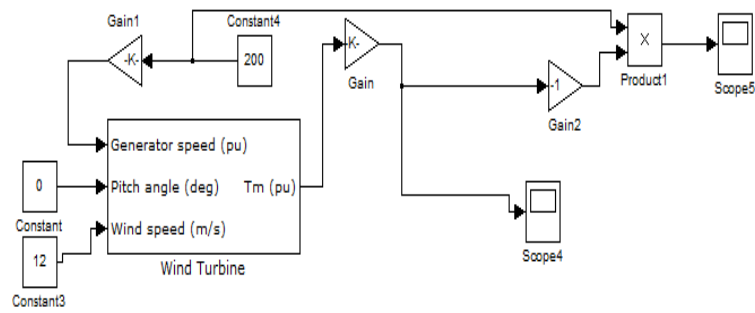

Figure 9. Torque Generation

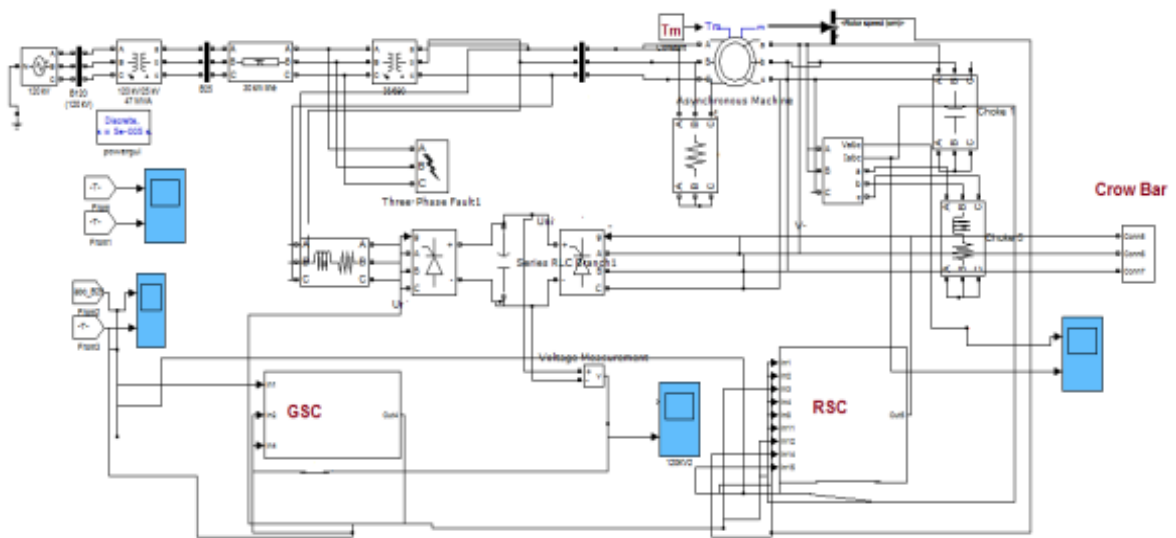

Figure 10. Conventional method for protection (Crow bar protection Scheme).





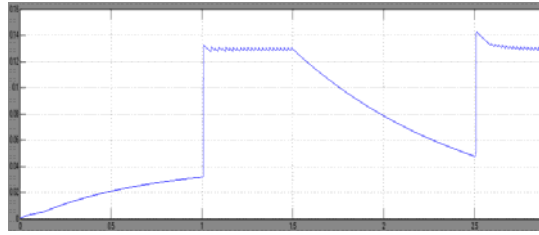

Figure 15. Capacitor Voltage

**5.2. Conventional Control (CROW BAR)**

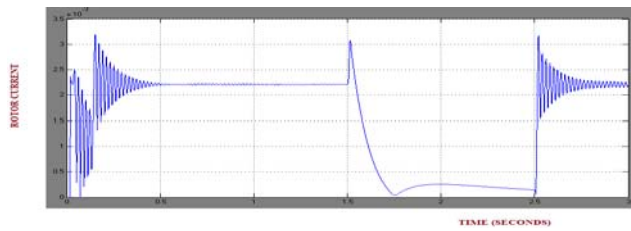

Figure 16. Rotor Fault current under conventional control technique.

**5.3. Under the Action of SFCL**

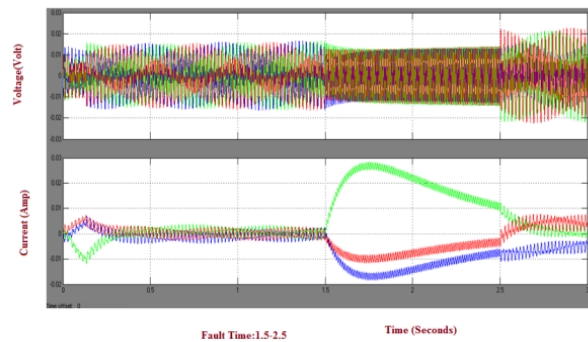

Figure 17. Limited Rotor voltage and current by the effect of SFCL

**5.4. Under the Action of SMES**

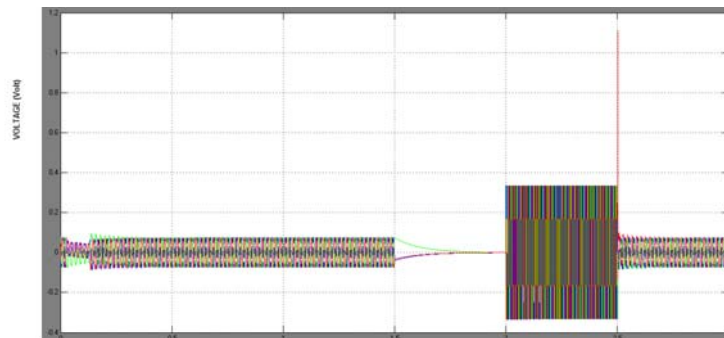

Figure 18. Stator Voltage by the action of SMES

## 6. CONCLUSION

In this paper a new topology has been proposed for grid connection during symmetrical fault condition to enhance the variable speed driven DFIG fed AC-DC-AC system fault ride-through capability. The proposed technology is simulated in MATLAB using powersim toolbox. Simulation results prove that the proposed control strategy is able to provide full ride through to the generator and power system capability can be improved. An SFCL-MES circuit is very intensive to enhance the LVRT capability and smoothed the power output of a DFIG based wind turbine. The SFCL-MES has no influence on the power generation of the DFIG based wind turbine. Co-ordinated operation of SMES with SFCL is used to improve the overall performance.

## APPENDIX

Table 1. DFIG simulation values.

Symbol	Quantity	Value
$V_s$	Stator line voltage	690V
$\omega_s$	Synchronous speed	$2\pi 50$
$L_m$	Magnetizing inductance	2.5pu
$L_{ls}, L_{lr}$	Stator and rotor leakage inductance	0.11, 0.07pu
$R_s, R_r$	Stator and rotor resistance	0.003pu
$P$	Number of pole pairs	2
$S$	Apparent power	1.5MW
$N_r$	Rotor to stator turns ratio	3

Table 2. Drive train details.

Symbol	Quantity	Value
$R$	Rotor radius	31.5m
$V_r$	Rated wind speed	12m/s
$\rho$	Air density	1.29kg / m <sup>3</sup>
$J_r$	Rotor inertia	$6.467 \times 10^5 \text{ kgm}^2$
$J_g$	Generator inertia	34.4kgm <sup>2</sup>
$B_{rs}$	Shaft damping coefficient	31901Nm / rad / s
$K_{rs}$	Shaft stiffness coefficient	$9.036 \times 10^3 \text{ Nm / rad}$
$B_r$	Rotor friction coefficient	91.87Nm / rad / s
$B_g$	Generator friction coefficient	0.2Nm / rad / s
$n_g$	Gearbox ratio	65.23

## REFERENCES

- [1] M Anju and R Rajasekaran. "Co-Ordination Of SMES With STATCOM For Mitigating SSR And Damping Power System Oscillations In A Series Compensated Wind Power System". *IEEE 2013 International Conference on Computer Communication and Informatics (ICCCI -2013)*. 2013.
- [2] J Morren and SWH de Haan. "Ride through of wind turbines with doubly-fed induction generator during a voltage dip". *IEEE Transaction. Energy Converters*. 2005; 20(2): 707–710.
- [3] L Peng, B Francois, and Y Li. "Improved crowbar control strategy of DFIG based wind turbines for grid fault ride-through". in Proc. IEEE Appl. Power Electronic. Conf. 2009: 1932–1938.
- [4] X Yan, G Venkataramanan, Y Wang, Q Dong, and B Zhang. "Grid-fault tolerant operation of DFIG wind turbine generator using a passive resistance network". *IEEE Transaction. Power Electron*. 2011; 26(10): 2896–2905.
- [5] C Abbey, W Li, L Owatta, and G Joos. "Power electronic converter control techniques for improved low voltage ride through performance in WTGs". in Proc. IEEE Power Electronics. Spec. Conf. 2006: 1–6.
- [6] C Abbey and G Joos, "Short-term energy storage for wind energy applications". in Proc. IEEE Ind. Appl. Conf., 2005: 2035–2042.
- [7] C Abbey and G Joos. "Supercapacitor energy storage for wind energy applications". *IEEE Transaction. Ind. Appl*. 2007; 43(3): 763–776.
- [8] D Xiang, L Ran, P Tavner, and S Yang. "Control of a doubly fed induction generator in a wind turbine during grid fault ride through". *IEEE Trans. Energy Convers*. 2006; 21(3) 652–662.

- [9] J Yao, H Li, Y Liao, and Z Chen. "An improved control strategy of limiting the DC-link voltage fluctuation for a doubly fed induction wind generator". *IEEE Trans. Power Electron.* 2008; 23(3): 1205–1213.
- [10] D Santos-Martin, JL Rodriguez-Amenedo, and S Arnaltes. "Providing ride-through capability of a doubly fed induction generator under unbalanced voltage dips". *IEEE Transactions. Power Electronics.* 2009; 24(7) 1747–1757.
- [11] J Liang, W Qiao, and RG Harley. "Direct transient control of wind turbine driven DFIG for low voltage ride-through". Presented at the *IEEE Symp. Power Electron. Mach. Wind Appl.*, Lincoln, NE, Jun. 24–25, 2009.
- [12] J Liang, W Qiao, and RG Harley. "Feed-forward transient current control for low-voltage ride-through enhancement of DFIG wind turbines". *IEEE Trans. Energy Convers.* 2010; 25(3): 836–843.
- [13] A Pinteá, H Wang, N Christov, P Borne, D Popescu, and A Badea. "Optimal control of variable speed wind turbines". in Proc. 19th Mediterranean Conf. Control Autom. Corfu, Greece. 2011: 838–843.
- [14] HS Ko, J Jatskevich, G Dumont, and GG Yoon. "An advanced LMbased- LQR design for voltage control of grid connected wind farm". *Electric Power Systems. Res.* volume. 2008; 78(4): 539–546.
- [15] R Vepa. "Nonlinear, optimal control of a wind turbine generator". *IEEE Trans. Energy Convers.* 2011; 26(2): 468–478.
- [16] Jing-Shi. "SMES Based Excitation System for Doubly-Fed Induction Generator in Wind Power Application". *IEEE Transactions On Applied Superconductivity.* 2011; 21(3).
- [17] Andres E Leon. "Fault Ride-Through Enhancement of DFIG-Based Wind Generation Considering Unbalanced and Distorted Conditions". *IEEE Transactions On Smart Grid.* 2012; 3(1).
- [18] Issarachai Ngamroo. "Optimized SFCL and SMES Units for Multi machine Transient Stabilization Based on Kinetic Energy Control". *IEEE Transactions On Applied Superconductivity.* 2013; 23(3).
- [19] Yufei Tang. "Optimized Control of DFIG-Based Wind Generation Using Sensitivity Analysis and Particle Swarm Optimization". *IEEE Transactions On Smart Grid.* 2013; 4(1).
- [20] Sung-Hun Lim. "Study on Correction of Protective Devices for Application of a SFCL in a Power Distribution System With a Dispersed Generation". *IEEE Transactions On Applied Superconductivity.* 2013; 23(3).
- [21] Jun Yao. "Enhanced Control of a DFIG-Based Wind-Power Generation System With Series Grid-Side Converter Under Unbalanced Grid Voltage Conditions". *IEEE Transactions on Power Electronics.* 2012; 23(2).
- [22] Hamed HH Aly, ME El-Hawary. "The current status of wind and tidal in-stream electric energy resources". *American Journal of Electrical Power and Energy Systems.* 2013; 2(2): 23-40.
- [23] Andres E Leon. "Fault Ride-Through Enhancement of DFIG-Based Wind Generation Considering Unbalanced and Distorted Conditions". *IEEE Transactions On Energy Conversion.* 2012; 27(3).
- [24] Van-Tung Phan. "Performance Enhancement of Stand-Alone DFIG Systems With Control of Rotor and Load Side Converters Using Resonant Controllers". *IEEE Transactions On Energy Conversion.* 2012; 27(3).
- [25] Woo Jae Park. "Parameter Optimization of SFCL With Wind-Turbine Generation System Based on Its Protective Coordination". *IEEE Transactions On Applied Superconductivity.* 2012; 21(3).

## BIOGRAPHIES OF AUTHORS



**Anju M** was born in India, in 1990. She got B.Tech degree (2011) in Electrical and Electronics engineering from University college of engineering thodupuzha, kerala india. She is completed her masters degree(2013) in Power Systems engineering from SNS College of technology, Tamilnadu India.

Currently she is working in Karpagam institute of technology, Coimbatore. She is published about 7 research works in various reputed journals. Her research area is application of Super conducting magnetic energy storage in wind energy applications.

Ms Anju is a member of Indian Society of Electrical and Electronic Engineers From 2011. She is also a member of Indian Society Of Technical Education From 2010



**R Rajasekaran** was born in India, in 1982. He got B.Tech degree in Electrical and Electronics from IFET college of engineering, Villupuram, Tamilnadu, india. He completed his masters degree in Electrical Drives and Embedded control engineering from ANNA university, Coimbatore Tamilnadu India.

He have eight years of working experience in different firms. One year experience in Triunfo technology Tamilnadu and Seven years of experience in teaching. He is doing his research work in DFIG based wind farm. Currently he is doing his PhD in "Performance Improvement of Grid Connected Wind Turbine Driven Doubly Fed Induction Generators (DFIGs)". Mr Rajasekaran is a member a member of Indian Society Of Technical Education From 2010.