

Battery Control Strategy for Hybrid Power Generation Systems

Junaidi, Ayong Hiendro, Yohannes M. Simanjuntak

Department of Electrical Engineering, Tanjungpura University

Article Info

Article history:

Received Jun 12, 2012

Revised Jul 21, 2012

Accepted Jul 26, 2012

Keyword:

Battery control strategy

Diesel generator

Fuel consumption

Hybrid system

SOC

ABSTRACT

Standalone diesel generators (DGs) are widely utilized in remote areas in Indonesia. Some areas use microhydro (MH) systems with DGs backup. However, highly diesel fuel price makes such systems become uneconomical. This paper introduces hybrid photovoltaic (PV)/MH/DG/battery systems with a battery control strategy to minimize the diesel fuel consumption. The method is applied to control the state of charge (SOC) level of the battery based on its previous level and the demand load condition to optimize the DG operation. Simulation results show that operations of the hybrid PV/MH/DG/battery with the battery control strategy needs less fuel consumption than PV/MH/DG and MH/DG systems.

Copyright © 2012 Institute of Advanced Engineering and Science.
All rights reserved.

Corresponding Author:

Ayong Hiendro,
Department of Electrical Engineering,
Tanjungpura University,
Jalan Jendral Ahmad Yani, Pontianak 78124, Indonesia.
Email: ayongh2000@yahoo.com

1. INTRODUCTION

Many remote areas in Indonesia are mainly powered by standalone DGs. Some areas with rivers flowing potential use MH systems with DGs as backup. In the MH/DG system, the DG supplies load if the MH generates low energy and cannot fulfill the demand load. This system runs with high cost in the long period due to highly diesel fuel price. Introducing the PV/battery into the system will reduce the DG operation and hence decrease diesel fuel consumption. However, without using a proper charging/discharging control strategy, it will reduce the battery lifetime and, consequently, increase cost of the battery.

Many battery charging control techniques have been developed for dispatching fluctuating energy resources, such as wind farms [1]-[6]. The papers in [1]-[4] propose a simple scheme to the battery charging/discharging strategy. The battery stores excess energy and discharges it when the demand is large. Teleke et al. [5] introduce the ruled-based control method to support the intermittent energy resources (PV systems and wind farms) on an hourly basis. Li et al. in [6] uses a fuzzy logic based control method to regulate the battery SOC at expected conditions.

The MH resource is more stable than wind energy. However, in some areas in Indonesia, the water debit is dependent upon the seasons. The rainy season increases the water flow and, on the contrary, the water debit is greatly decreased at the dry season. In order to fulfill the demand, the MH needs other energy resources as backup. This paper proposes a battery control strategy to simulate the performance of a hybrid PV/MH/DG/battery system in Sajingan. This site is located in West-Borneo and lies between 2°08' - 0°33' North Latitudes and 108°39' - 110°04' East Longitudes.

2. SYSTEM MODEL

The system model consists of PV, MH, GD and battery is presented in Figure 1. The hourly electric power flow of the system is expressed by

$$P_v(t) + P_d(t) + P_h(t) + P_b(t) = P_l(t) \quad (1)$$

where P_v , P_d , P_h , and P_b are output power of PV, DG, MH, and battery, respectively, while P_l denotes demand load. The battery output power becomes positive if the battery is discharging. In the reverse process, the battery output power is negative.

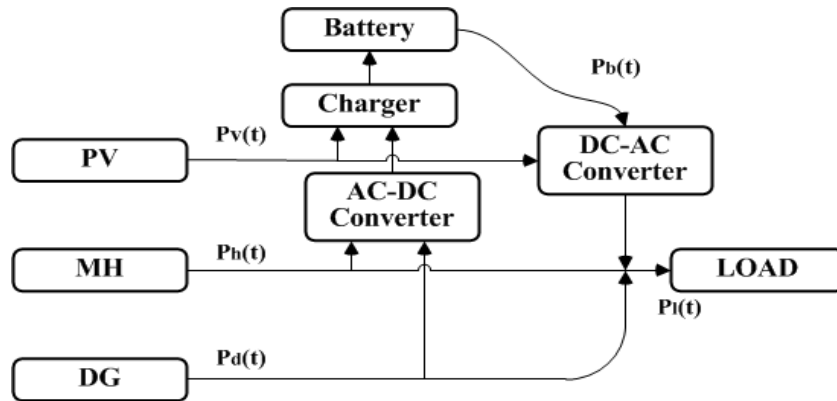

Figure 1. System model scheme

2.1. Photovoltaic power

The PV output power is a function of solar intensity (R , kW/m^2) and panel temperature (T , $^{\circ}\text{C}$). For the PV efficiency ϵ_v and panel area A , the hourly PV output power is defined by

$$P_v(t) = \epsilon_v \cdot A \cdot R(t) \cdot (1 - 0.005 \cdot (T(t) + 5)) \quad (2)$$

2.2. Microhydro power

The MH output power depends on the head available (h_{ef} , m) and debit of turbine (Q_t , m^3/s). The hourly MH output power is specified by

$$P_h(t) = 9.81 \cdot \epsilon_h \cdot h_{ef} \cdot Q_t(t) \quad (3)$$

where ϵ_h is the MH efficiency.

2.3. Diesel generator power and fuel consumption

The operating load influences the fuel consumption of the DG (F_d). The hourly fuel consumption of the DG at rated capacity (T_d) is defined by

$$F_d(t) = a \cdot T_d + b \cdot P_d(t) \quad (4)$$

where a and b denote coefficients of DG fuel consumption in L/kWh .

2.4. Battery and full energy cycles

Lead-acid batteries have ability to supply high currents and relatively low cost. These make the lead acid batteries suitable in hybrid power generations. However, the number of cycles of lead-acid batteries decreases exponentially when increasing the depth of discharge (DOD). Figure 2(a) shows the number of cycles versus the DOD for a typical lead acid battery.

If the number of full energy cycles is defined as how many times the full energy that can be taken out of a battery during its lifetime, it can be expressed by

$$(\text{number of full energy cycles}) = (\text{number of cycles}) \times (\text{DOD}) \quad (5)$$

The number of full energy cycles of a lead-acid battery is almost constant and independent to the DOD in a lower specific range. As seen in Figure 2(b), the number of full energy cycles is about 510 cycles with the DOD between 0% and 60%. In order to lengthen the battery life, the battery may not be operated at the DOD

higher than 60%. From the information given in Figure 2(b), the SOC ($SOC = 1 - DOD$) for this study is limited between 40% and 100%.

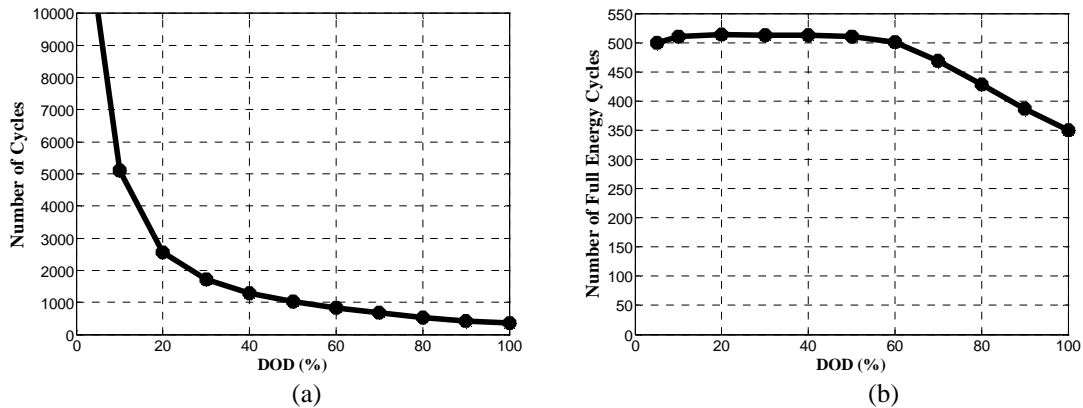

Figure 2. (a). Number of cycles versus DOD, (b). Number of full energy cycle versus DOD

3. BATTERY CONTROL STRATEGY PROCEDURE

The proposed battery control strategy applied in the PV/MH/DG/battery system has six main scenarios as shown in Table 1. The scenarios depend on the SOC of the battery ($X(t)$). If electricity supply from both PV and MH matches the demand load, the DG and battery do not operate (scenario 1). However, in the worst case (scenario 6), the DG must operate at its full capacity to support the PV/MH in fulfilling the electricity demand.

Table 1. Battery control strategy scenarios

Scenario	DG	Battery
1	Not operating	Not operating
2	Not operating	Energy storage
3	Not operating	Energy source
4	Operating	Energy storage
5	Operating	Energy source
6	Operating	Not operating

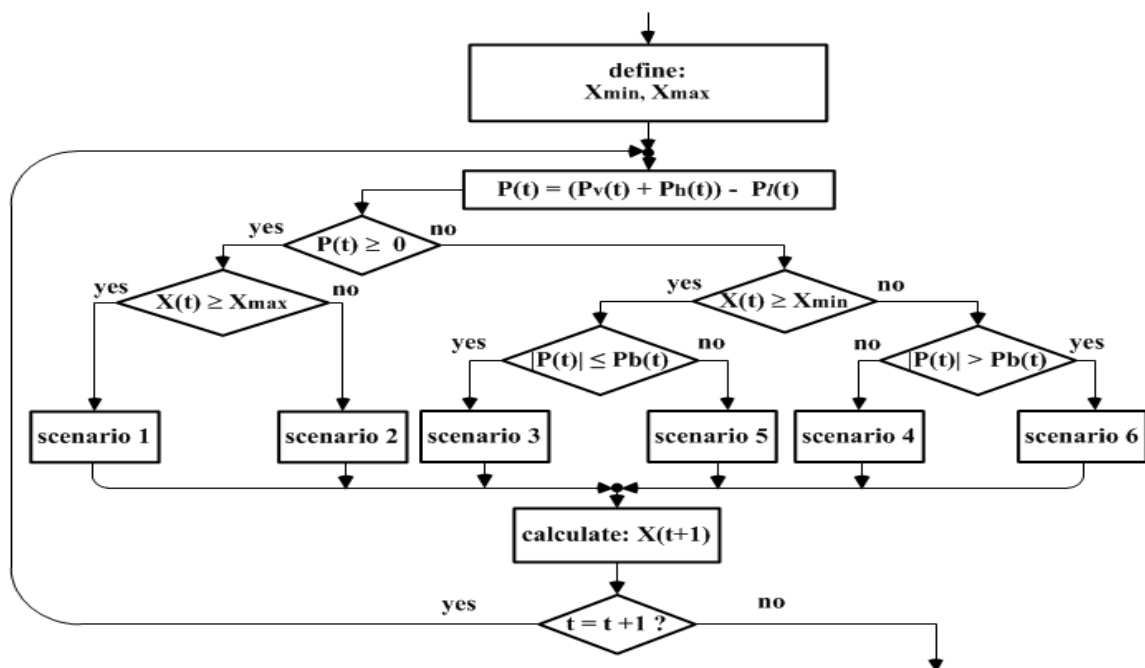

Figure 3. Flowchart of the propose strategy

Rule of the control strategy is presented in Figure 3. The SOC of the battery is limited between X_{\min} and X_{\max} levels. The current state SOC, $X(t+1)$, is calculated based on its previous state ($X(t)$), as specified by

$$X(t+1) = X(t) + \frac{I_b(t)}{C} \quad (6)$$

In (6), I_b denotes the battery current, while C is the nominal capacity of the battery. The current I_b is positive if the battery acts as an energy storage and negative if it is an energy source.

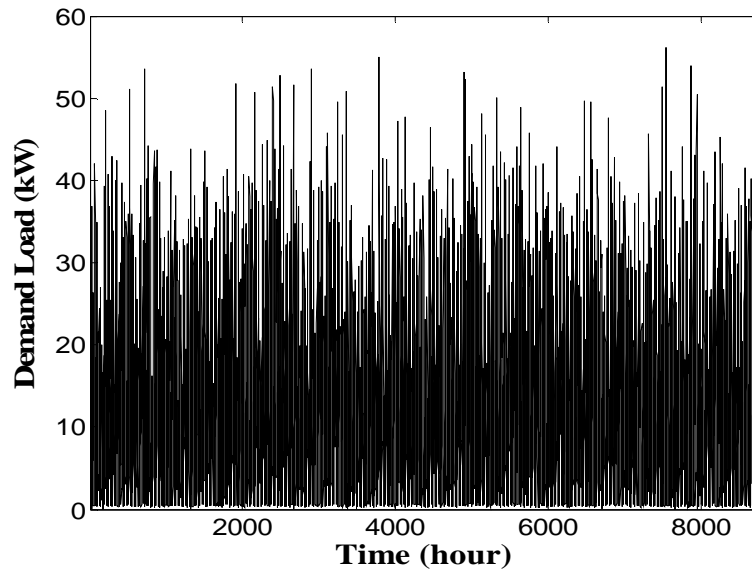

Figure 4. Hourly load distribution

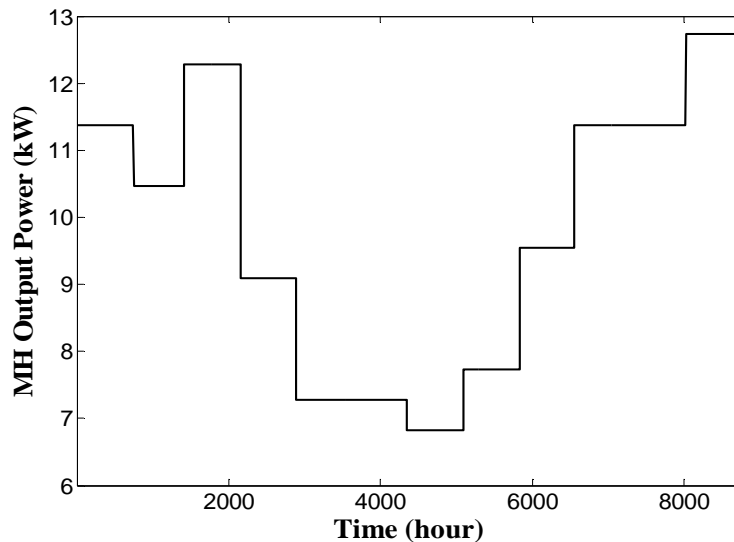

Figure 5. Hourly MH output power

Figure 4 shows a typical load profile in Sajingan (West Kalimantan) with the peak load of 56.25kW. From the hourly load profile, the daily energy demand is 307kWh. The design flow rate for the MH is 20L/s. The lowest flow rate measured at the site is 15L/s during dry season with the head of 60m. The hourly MH

output power is presented in Figure 5. The average solar radiation based on annual measurement is 5.73kW/m^2 . The hourly PV output power is shown in Figure 6. The coefficients of DG fuel consumption are $a = 0.08 \text{ L/kWh}$ and $b = 0.25 \text{ L/kWh}$, respectively. For this study, lead-acid batteries with the nominal capacities of $C = 1500\text{Ah}$ and the currents limit of 300A are used. The level of the SOC is set between $X_{\min} = 40\%$ and $X_{\max} = 100\%$.

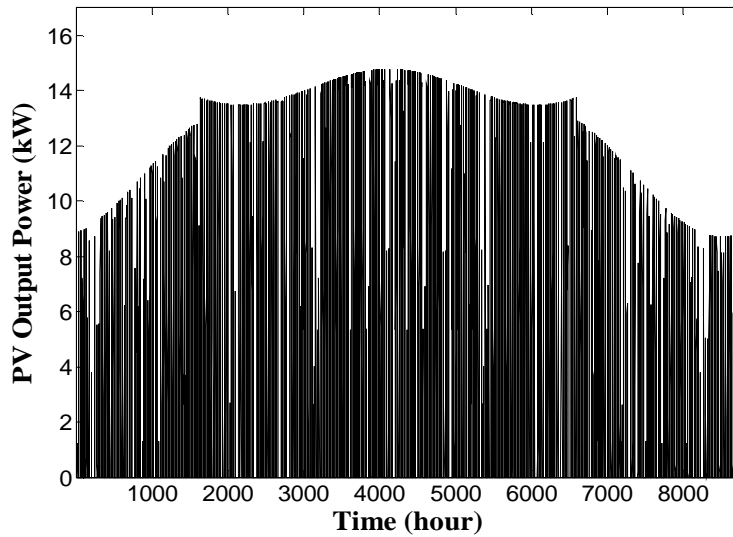

Figure 6. Hourly PV output power

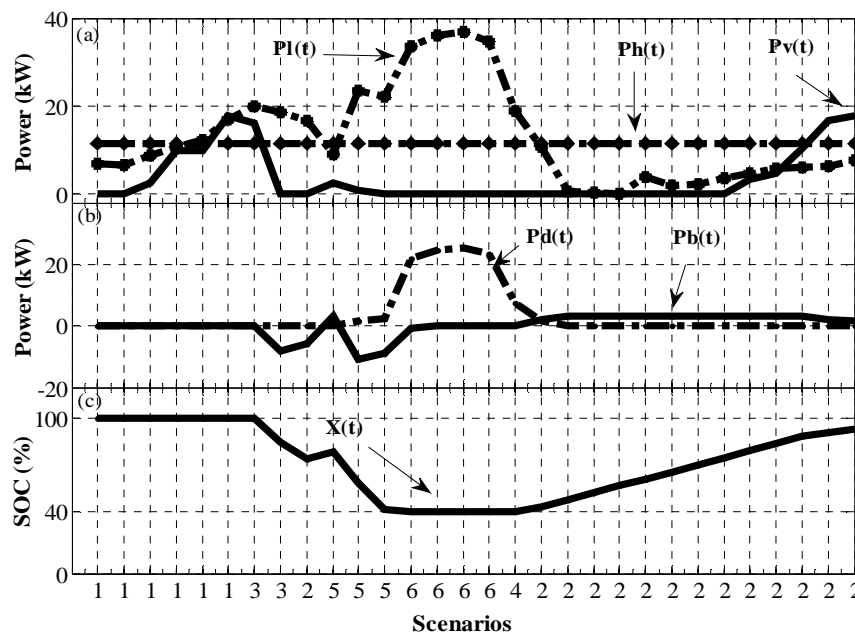

Figure 7. Load dispatch scenarios

The results of applying the battery control strategy are shown in Figure 7. Figure 7 presents the power output of the PV/MH/demand load (a), the DG/battery (b), and the SOC (c) within a specified time period. As shown in Figure 7, scenario 1 is employed when the demand is very low and the PV/MH can meet it. In this condition, the battery is in its maximum level. The demand is rising (as in scenario 3), and it needs the battery to be discharged down. In scenario 2, the demand is supplied by the PV/MH. The extra energy is

used to charge the battery and hence, SOC of the battery is going to rise. In scenario 5, the demand goes up and the PV/MH/DG with the battery is used all together to meet the demand. However, in scenario 6, the SOC of the battery has reached its minimum level (40%) and the demand is supplied by the PV/MH/DG without the battery. In scenario 4, the battery has chances to increase its SOC level from the presence of extra energy contributed by the PV/MH/DG.

Based on the simulation study, applying the battery control strategy to the hybrid power PV/MH/DG/battery system results in the fuel consumption of 13.988L/yr. This value is lower than the fuel consumption of the hybrid MH/DG (24.549L/yr) and PV/MH/DG (18.944L/yr) systems without the battery.

4. CONCLUSION

A battery control strategy has been proposed to reduce fuel consumption in a hybrid PVMH/DG/battery system. The method controls the DG and battery operations based on the previous level of the battery SOC and the demand load with six main scenarios. From simulation results, it has been shown that the PV/MH/DG/battery system with the proposed method needs less fuel consumption than the PV/MH/DG and MH/DG systems without the battery.

REFERENCES

- [1] E. Muljadi, C. P. Butterfield, R. Yinger, and H. Romanowitz, "Energy Storage and Reactive Power Compensator in a Large Wind Farm," in *Proc. 42nd AIAA Aerospace Sciences Meeting and Exhibit, Reno, NV, 2004*, pp.1-10.
- [2] A. Arulampalam, M. Barnes, N. Jenkins, and J. B. Ekanayake, "Power Quality and Stability Improvement of a Wind Farm Using STATCOM Supported with Hybrid Battery Energy Storage," in *Proc. Inst. Elect. Eng. Generation, Transmission and Distribution*, 2006, vol. 153, no. 6, pp. 701–710.
- [3] J. Zeng, B. Zhang, C. Mao, and Y. Wang, "Use of Battery Energy Storage System to Improve the Power Quality and Stability of Wind Farms," in *Proc. Int. Conf. Power System Technology*, 2006, pp. 1–6.
- [4] H. T. Le, S. Santoso, and W. M. Grady, "Development and Analysis of an ESS-Based Application for Regulating Wind Farm Power Output Variation," in *Proc. IEEE Power Energy Soc. Gen. Meeting, Calgary, Alberta, Canada*, Jul 26–30, 2009.
- [5] S. Teleke, M. E. Baran, S. Bhattacharya, and A. Q. Huang, "Rule-Based Control of Battery Energy Storage for Dispatching Intermittent Renewable Sources," *IEEE Transactions on Sustainable Energy*, vol.1 , no. 3, pp. 117-124, Oct2010
- [6] X. Li, D. Hui, L. Wu, and X. Lai, "Control Strategy of Battery State of Charge for Wind/Battery Hybrid Power System," in *Proc. IEEE International Symposium on Industrial Electronics (ISIE)*, 2010, pp. 2723-2726.

BIBOGRAPHS OF AUTHORS



Junaidi was born in Pontianak, Indonesia, in 1959. He received the M.Eng degree in electrical engineering from Bandung Institute of Technology (ITB), Bandung, Indonesia in 1994. His professional research is in electricity conservation, management energy and energy innovation policy. He is currently a senior lecturer in Department of Electrical Engineering, Faculty of Engineering, Tanjungpura University, Pontianak, Indonesia.



Ayong Hiendro was born in Ketapang, Indonesia, in 1969. He received the M.Eng degree in electrical engineering from Bandung Institute of Technology (ITB), Bandung, Indonesia in 2000. He is currently a senior lecturer in Department of Electrical Engineering, Faculty of Engineering, Tanjungpura University, Pontianak, Indonesia.



Yohannes M. Simanjuntak was born in Ketapang, Indonesia, in 1956. He received M.Eng degree in electrical engineering from Tanjungpura University (UNTAN), Pontianak, Indonesia. His professional research is in management energy. He currently is an associated professor in Department of Electrical Engineering, Faculty of Engineering, Tanjungpura University, Pontianak, Indonesia.