

Design and Characterization of Compact Microstrip Patch Antenna Using “Split Ring” Shaped Metamaterial Structure

P.K. Singhal, Bimal Garg

Department of Electronics Engineering, Madhav Institute of Technology and Science, Gwalior-474005, India

Article Info

Article history:

Received Jul 16, 2012

Revised Aug 20, 2012

Accepted Sep 22, 2012

Keyword:

Rectangular Microstrip Patch Antennas

Double Negative Left-Handed Metamaterial

SPLIT RING

NRW

ABSTRACT

Authors analyzed and explored a significant concept of micro-strip patch antenna configured by double negative left handed metamaterial which have dielectric permittivity & magnetic permeability both negative simultaneously. Basic aim of this paper is to explain the general properties of rectangular micro-strip patch antenna with metamaterial structure like return loss, bandwidth, directivity and gain. In this paper authors have compared the return loss, bandwidth & gain of the micro-strip patch antenna at a frequency of 2GHz and height of 3.2 mm from the ground plane with “SPLIT RING” Shaped double negative left-handed metamaterial. It has been observed that the return loss has improved by 20dB. The complex permittivity and permeability of the proposed structure has been extracted by Nicolson-Ross-Weir (NRW) approach.

Copyright © 2012 Institute of Advanced Engineering and Science.
All rights reserved.

Corresponding Author:

Bimal Garg,
Department of Electronics Engineering,
Madhav Institute of Technology and Science,
Gwalior-474005, India.
e-mail: bimalgarg@yahoo.com

1. INTRODUCTION

The unusual properties of the metamaterials are utilized here in a Microstrip Patch Antenna at a frequency of 2GHz in order to achieve a more efficient Antenna. Metamaterials were first introduced by Veselago [1] in 1967. Metamaterials are manmade artificial materials which exhibit negative permittivity, negative permeability and negative refractive index [5-6], which is not found readily in the materials found in nature. For the proposed antenna only the negative permittivity and negative permeability are of importance. Veselago first analyzed theoretically the wave propagation in a material with a negative electric permittivity and a negative magnetic permeability. In such a left-handed (LH) material the electric field, the magnetic field, and the wave vector of an electromagnetic wave propagating obey the left-hand rule (instead of the right-hand rule for usual materials). Metamaterials permit patch antenna elements to cover a wider frequency range. Some applications for metamaterial antennas are wireless communication, space communications, global positioning system (GPS), satellites, space vehicle navigation, and airplanes.

The Rectangular Microstrip Patch Antenna consists of a conductive patch on substrate materials above a conductive ground plane. The excitation of the patch is accomplished via Microstrip feedline. This feed technique supply the electrical signal to the Patch which will be converted to an electromagnetic wave. This paper is organized as follows. The section 2 is concerned with the methodology used. The section 3 discusses the results of the paper and hence concludes the work.

All the simulation work is done on Computer Simulation Technology (CST-MWS) Software. Microsoft Excel Software has been used for verifying the Double Negative properties of the proposed design.

2. METHODOLOGY

The Rectangular Resonant Microstrip Patch Antenna is etched on FR4 (Lossy) substrate of thickness $h = 1.6\text{mm}$, and dielectric constant $\epsilon_r = 4.3$ by using PEC [4] (Perfect Electric conductor) as the conducting plane. The proposed design is based on "SPLIT RING" shaped metamaterial structure. The Rectangular Microstrip Patch Antenna (RMPA) parameters are calculated from the formulas given below.

2.1. Desired Parametric Analysis [2-3]:

Calculation of Width (W)

$$W = \frac{1}{2fr\sqrt{\mu_0\epsilon_0}} \sqrt{\frac{2}{\epsilon_r + 1}} = \frac{c}{2fr} \sqrt{\frac{2}{\epsilon_r + 1}} \quad (1)$$

Where,

c = free space velocity of light,

ϵ_r = Dielectric constant of substrate.

Effective dielectric constant is calculated from:

$$\epsilon_{\text{eff}} = \frac{\epsilon_r + 1}{2} + \frac{\epsilon_r - 1}{2} \left(\frac{1}{\sqrt{1 + \frac{12h}{W}}} \right) \quad (2)$$

The actual length of the Patch (L)

$$L = L_{\text{eff}} - 2\Delta L \quad (3)$$

Where,

$$L_{\text{eff}} = \frac{C}{2fr\sqrt{\epsilon\epsilon_{\text{eff}}}} \quad (4)$$

Calculation of Length Extension

$$\frac{\Delta L}{h} = 0.412 \frac{(\epsilon_{\text{eff}} + 0.3) \left(\frac{W}{h} + 0.264 \right)}{(\epsilon_{\text{eff}} + 0.258) \left(\frac{W}{h} + 0.8 \right)} \quad (5)$$

The RMPA is designed using the calculated parameters shown below in Table 1.

Table 1. RMPA Specifications:

	Dimensions	Unit
Dielectric Constant (ϵ_r)	4.4	-
Loss Tangent ($\tan \delta$)	0.02	-
Thickness (h)	1.6	mm
Operating Frequency	2	GHz
Length (L)	34.30	mm
Width (W)	44.20	mm
Cut Width	5	mm
Cut Depth	10	mm
Path Length	32.82175	mm
Width Of Feed	3.009	mm

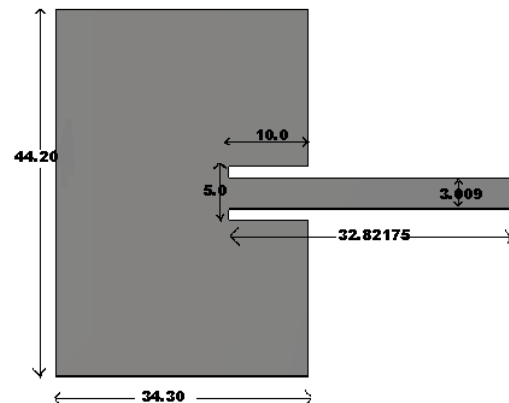

Figure 1. Dimensional View of Rectangular Microstrip Patch Antenna at 2GHz

3. DESIGNING, SIMULATION, FABRICATION & MEASUREMENT OF RMPA AT 2GHZ

A rectangular Microstrip Patch Antenna (RMPA), with a recessed Microstrip feedline, backed by a perfect electrical conductor [4] (PEC) ground plane is shown in Figure 1. The antenna is designed to resonate at 2GHz.

The return loss is a main parameter in almost all antenna analysis. It is also known as the S11 parameter in the two port network. It measures the antenna's absorption of the fed power over the total power fed. Initially, the impedance bandwidth [17] of the Rectangular Patch Antenna is 8.6MHz (1.9624-1.971GHz), and the Return Loss is -10.172dB as shown in Figure 2.

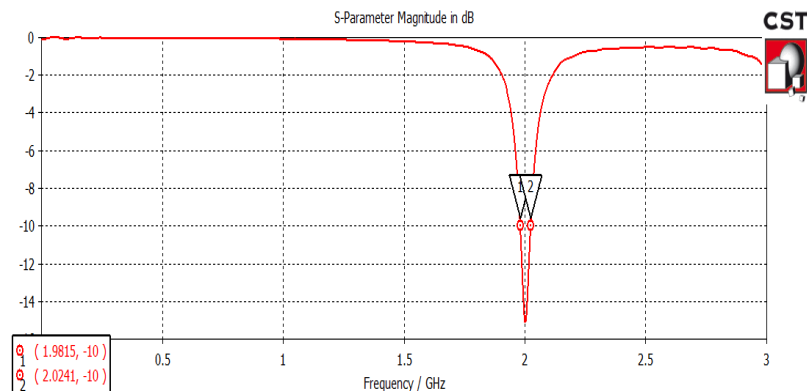

Figure 2. Simulated Result of Rectangular Microstrip Patch Antenna showing Return Loss of -15.09dB and Bandwidth of 42.6MHz (1.9815-2.0241)

The radiation pattern of an antenna is generally its most basic requirement because it determines the distribution of radiated energy in space. Figure 3 shows the Radiation Pattern of RMPA resonating at 2GHz.

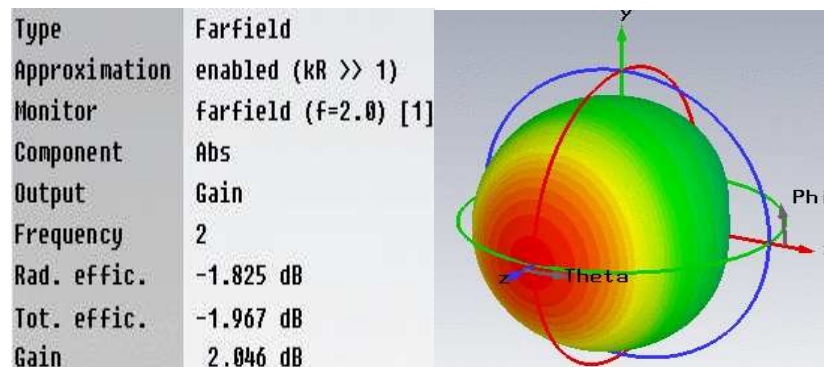

Figure 3. Radiation Pattern of Rectangular Microstrip Patch Antenna showing Gain of 2.046dB [11]

After designing, simulating, fabricating & measuring the RMPA potential parameters at the operating frequency, the proposed “SPLIT RING” shaped [15] [17] metamaterial structure is taken into account.

Before incorporating the proposed structure with the Rectangular Microstrip Patch Antenna, the Double Negative metamaterial properties of the proposed structure are verified by using NRW approach.

4. NICOLSON-ROSS-WEIR (NRW) APPROACH

The proposed structure is placed between the two waveguide ports [10] at the left & right of the X-Axis (shown in Figure 6) in order to calculate the S11 and S21 parameters so as to prove that the proposed structure possesses Double Negative Metamaterial properties. In Figure 6, X-Plane was defined as Perfect Electric Boundary (PEB) and Z-Plane was defined as the Perfect Magnetic Boundary (PMB).

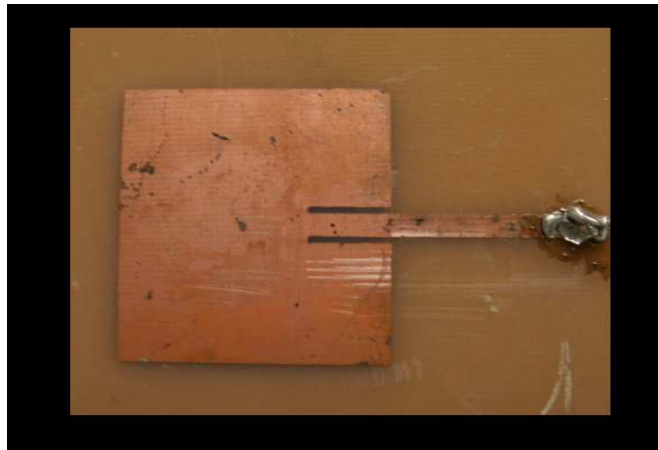

Figure 4. Photograph of finally fabricated RMPA (top layer)

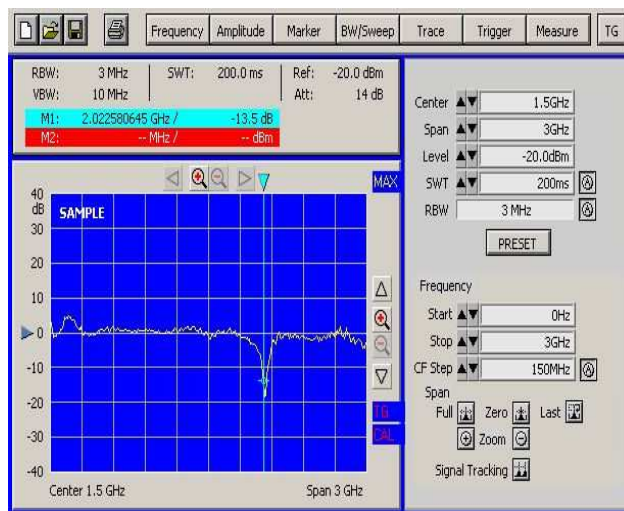

Figure 5. Measured Result of Rectangular Microstrip Patch Antenna showing Return Loss of -18dB

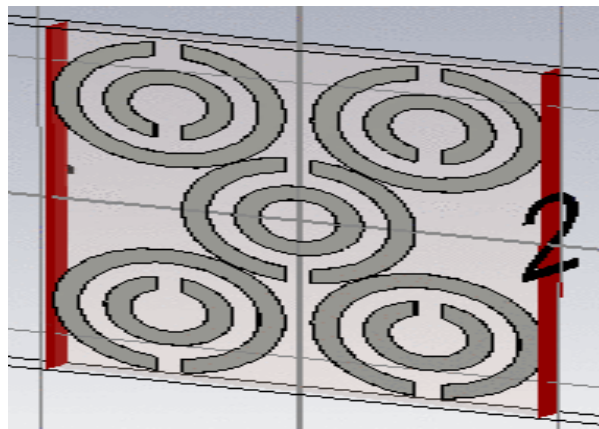

Figure 6. Proposed Metamaterial Structure placed between the two Waveguide Ports at the left & right of the X-Axis

The NRW modeling is the most common used method to perform the calculation of complex permittivity and permeability of materials. The obtained S-parameters are then exported to Microsoft Excel

Software for calculating the value of the permittivity and permeability of the proposed design, using the Nicolson-Ross-Weir (NRW) approach [9] [10].

4.1. Equations used for calculating permittivity & permeability using NRW approach [10], [13]:

$$\mu_r = \frac{2.c(1 - v_2)}{\omega.d.i(1 + v_2)} \tag{6}$$

$$\epsilon = \mu_r + \frac{2.S_{11}.c.i}{\omega.d} \tag{7}$$

Where,

$V_1 = S_{11} + S_{21}$

$V_2 = S_{21} - S_{11}$

ω = Frequency in Radian,

d = Thickness of the Substrate,

c = Speed of Light,

V_1 = Voltage Maxima, and

V_2 = Voltage Minima.

The Figure 7 & 8 shows that the proposed design have negative values of permittivity and permeability at the operating frequency.

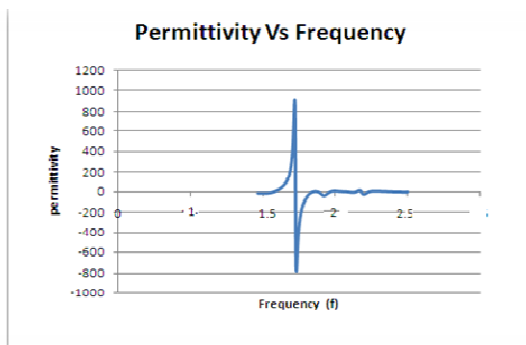

Figure 7. Permittivity versus Frequency Graph

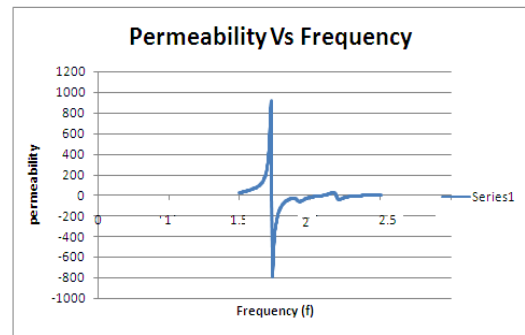

Figure 8. Permeability versus Frequency Graph

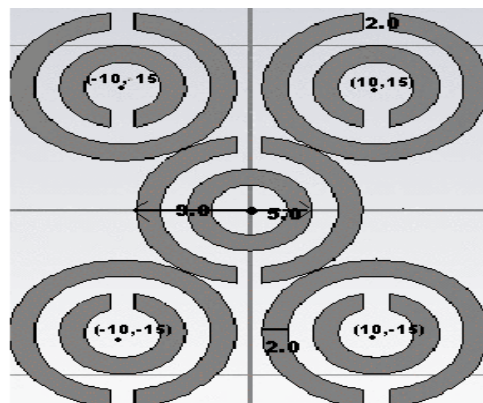

Figure 9. Rectangular Microstrip Patch Antenna loaded with “SPLIT RING” shaped metamaterial structure (all dimensions in mm)

5. DESIGNING AND SIMULATION OF “SCATTERD SQUARE RINGS” DOUBLE NEGATIVE METAMATERIAL STRUCTURE.

The Figure 9 below shows the RMPA loaded with the “SPLIT RING” shaped metamaterial structure at a height of the 3.2mm from the ground plane & Figure 11(a) and 11(b) shows the fabricated structure & experimental verification respectively.

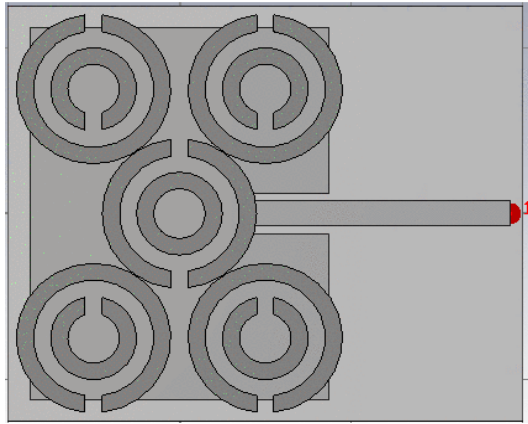

Figure 10. RMPA loaded with “SPLIT RING” shaped metamaterial structure at a height of 3.2mm from the ground plane

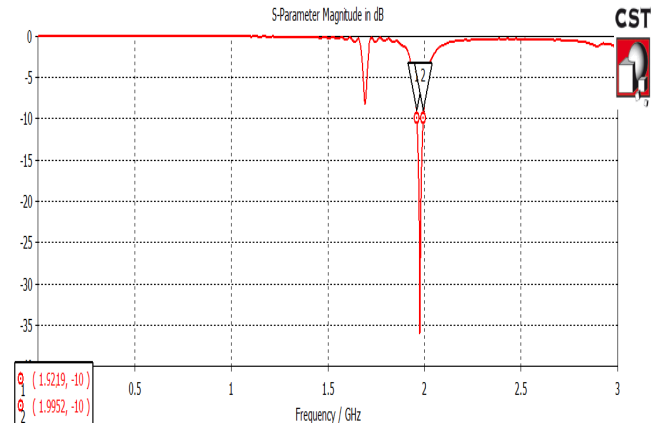

Figure 11. Simulated result of proposed Metamaterial Structure showing Return Loss of -36.81dB and Bandwidth of 73.3MHz (1.9619-1.9952)

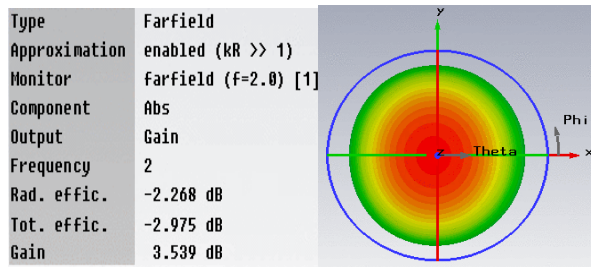

Figure 12. Radiation Pattern of RMPA loaded with “SPLIT RING” shaped metamaterial structure showing Gain of 3.539dB.

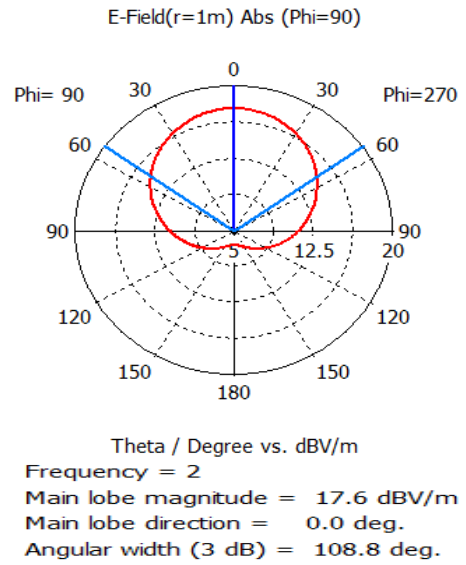

Figure 13 (a). E Field of RMPA loaded with “SPLIT RING” shaped metamaterial structure at 2GHz [18]

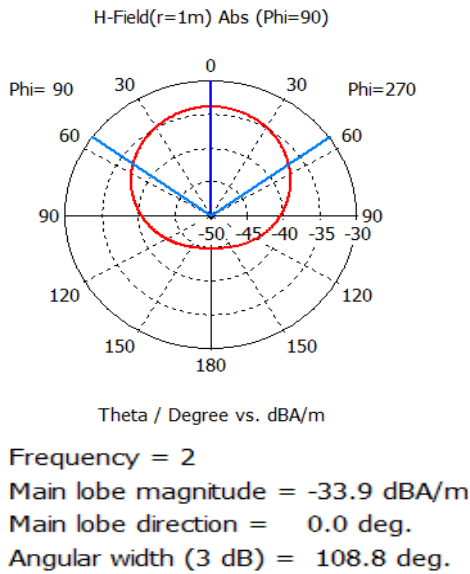

Figure 13 (b). H Field of RMPA loaded with “SPLIT RING” shaped metamaterial structure at 2GHz



Figure 14 (a). Fabricated “SPLIT RING” shaped metamaterial structure at a height of 3.2mm from the ground plane



Figure 14 (b). Experimental Testing of RMPA loaded with “SPLIT RING” shaped metamaterial structure on Spectrum Analyzer

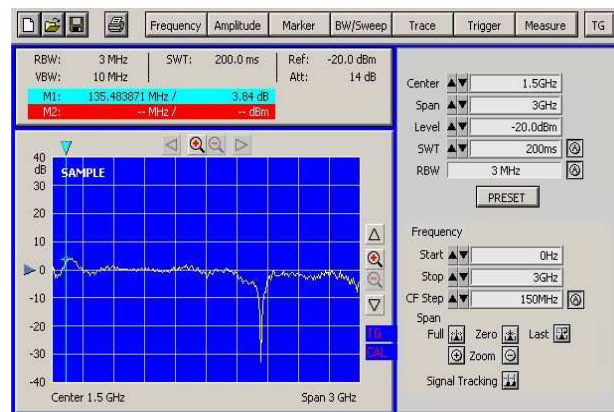

Figure 15. Measured Result of Rectangular Microstrip Patch Antenna loaded with “SPLIT RING” shaped metamaterial structure showing Return Loss of -33dB

6. RESULTS AND CONCLUSION

When the proposed “SPLIT RING” shaped metamaterial structure is simulated using CST Software at the resonating frequency of 2GHz, it has been found that the potential parameters [13-14] (gain, bandwidth, & return loss) of the Antenna improves significantly in comparison to RMPA alone. Figure 2 & 11 shows that the Return Loss of the proposed metamaterial structure is reduced by 21.72dB & the bandwidth increases by 30.7MHz [8][16]. Radiation Pattern in Figure 3 & 12 shows that the Gain of the proposed metamaterial structure has improved by 1.493dB [7][12]. The results measured by the spectrum analyzer are shown in Figure 5 & 15. The purpose of the work is to design a small size, less power consumed and low cost antenna that can be used for wideband communication applications. It is clear from the investigation that measured and simulated results are likely same, but some fabrication losses and environmental condition alter the results minutely.

REFERENCES

- [1] V. G. Veselago, "The electrodynamics of substances with simultaneously negative values of μ and ϵ ," *Sov. Phys. Uspekhi*, vol. 10, no. 4, pp. 509–514, 1968.
- [2] C. A. Balanis, "Antenna Theory and Design," *John Wiley & Sons, Inc.*, 1997.
- [3] W.L. Stutzman, G.A. Thiele, *Antenna Theory and design*, John Wiley & Sons, 2nd Ed., New York, 1998.
- [4] J.B. Pendry *et al*, "Magnetism from conductors and enhanced nonlinear phenomena," *IEEE Trans. Micro Tech.* vol.47, no.11, 1999, pp.2075-2081.
- [5] D.R. Smith *et al*, "Composite medium with simultaneously negative permeability and permittivity," *Phys Rev Lett* ,84, pp. 4184–4187, May 2000.
- [6] J.B. Pendry, "Negative refraction makes a perfect lens," *Phys Rev Lett-85*," 2000, pp. 3966–3969.
- [7] N. Engheta, R. W. Ziolkowski, "Metamaterial Physics & Engineering Explorations," *Wiley-IEEE Press*, 2006.
- [8] Ahmad A. Sulaiman and Ahmad S. Nasaruddin, "Bandwidth Enhancement in patch antenna by metamaterial substrate," *European Journal of scientific research*, 2010.
- [9] Huda A. Mazid *et al*, "Left-handed metamaterial design for microstrip antenna application", *IEEE International RF and Microwave conference*, 2008.
- [10] G. Lovat *et al*, "Combinations of low/high permittivity and/or permeability substrates for highly directive planar metamaterial antennas," *IET Microw. Antennas Propag.* 1, 177, 2007.
- [11] S. Pyo *et al*, "Offset-fed metamaterial antenna for radiation mode generation with efficiency improvement", *IET Microw. Antennas Propag.* 4, 1481 2010.
- [12] H.A. Majid *et al*, Microstrip Antenna gain enhancement using left-handed metamaterial structure," *progress in Electromagnetic Research M*. Vol.8, 235-247, 2009.
- [13] Bimal Garg *et al*, "Design of factored 'X' shaped metamaterial structure for enhancement of patch antenna gain", *International Conference on Communication Systems and Network Technologies*, 2011.
- [14] Bimal Garg *et al*, Enhancement of Gain and Directivity of Rectangular Resonant Microstrip Patch Antenna Loaded with "SYMMETRIC W" shaped Double Negative Left-Handed inspired metamaterial," *National Conference on Recent Advances in Microwave Engineering*, 2011.
- [15] C. M. Krowne, "Low loss guide wave propagation in a left-handed microstrip structure using dispersive split ring-rod combination metamaterial," *IET Microw. Antennas Propag.*, 1, 887, 2007.
- [16] J. Lee and S. Lim, "Bandwidth-enhanced and polarization-insensitive metamaterial absorber using double resonance," *Electron Lett.* 47, vol. 8, 2011.
- [17] Zhu, C. *et al*, C.H.: "Multiresonant metamaterial based on asymmetric triangular electromagnetic resonators", *IEEE Antennas Wirel. Propag. Lett.*, vol. 9, pp. 99–102, 2010.
- [18] D. Kim and M. Kim, "Narrow-beamwidth T-shaped monopole antenna fabricated with metamaterial wires", *Electron Lett.*, 44, 179, 2008.

BIOGRAPHIES OF AUTHORS



P.K. Singhal presently working as a professor and head of department of electronics, Madhav Institute of Technology and Science, Gwalior. Completed number of research projects sponsored by department of Science and Technology, Govt. of India and All India for Technical Education, New Delhi, University Grants Commission, New Delhi and M.P. Council of Science and Technology, Bhopal. Received AICTE career award and DST Young Scientist awards.



Bimal Garg received his B.E. degree in Electronics Engineering from Madhav Institute of Technology and Science, Gwalior, Jiwaji University; M.P. in 1984; the M.E. degree in Power Electronics from Shri Govindram Institute of Technology and Science, Indore, M.P., Devi Ahilya Bai Vishwavidyalaya Indore, in 1999; and pursuing his Ph.D. degree in design and analysis of microstrip antenna using metamaterial from Rajiv Gandhi Proudyogiki Vishwavidyalaya, Bhopal, M.P. He is associate professor in the department of electronics engineering at Madhav Institute of Technology and Science, Gwalior, M.P., since 1986. He has teaching experience of about 25 years for UG and PG courses. His research interests include microwave engineering. At present he is engaged in design of patch antenna using metamaterial and its various applications.