

Transient Stability Enhancement of Power System Using TCSC

P. Sunilkumar

Department of Electrical and Electronics Engineering
Madanapalle Institute of Technology & Science, India

Article Info

Article History:

Received Apr 12th, 2012

Revised May 25th, 2012

Accepted Jun 4th, 2012

Keyword:

SMIB system

Transient Stability

TCSC

Self-tuning Fuzzy

PID Controller

Fixed series compensation

ABSTRACT

This project presents the variable effective fundamental equivalent reactance capability of TCSC for enhancing the transient stability of power systems. For obtaining the varying effective fundamental equivalent reactance, two different controllers namely a speed deviation based Self-tuning Fuzzy PID Controller and a nonlinear controller are used. To validate the performance of the control schemes, the simulation studies are carried out on a single machine infinite bus system using MATLAB/ SIMULINK software package. The results of computer simulation indicate that Self-tuning Fuzzy PID controlled TCSC can not only improve the static stability of system, but also effectively damp power oscillation and enhance the transient stability of system when the power system suffers small disturbance and short circuit. In addition, it also illuminates that Self-tuning Fuzzy PID Controlled TCSC is more effective than nonlinear control, traditional PID control and fixed series compensation.

Copyright © 2012 Institute of Advanced Engineering and Science.
All rights reserved.

Corresponding Author:

P. Sunilkumar,

Department of Electrical and Electronics Engineering,

Madanapalle Institute of Technology & Science, India

Email: sunny.303365@gmail.com

1. INTRODUCTION

Power system has entered a new stage of a larger system with EHV (extra high voltage) long distance transmission and inter-regional networking. The development of socioeconomic makes the modern transmission grid management and operation changed, the demand of its security, stability, high efficiency, and flexible operational control is increasing, so developing new means of regulation to enhance its controllable is emergence. Thyristor controlled series capacitor (TCSC) is a kind of new power system equipment developed from the conventional fixed series capacitor. Its effective fundamental equivalent reactance can be controlled continuously by controlling the thyristor in a relatively large range, either capacitive or inductive. As a novel method for electrical network control, TCSC can be utilized in the power system transient stability enhancement, power system oscillation damping, the SSR mitigation and load flow control [1].

Flexible AC Transmission System (FACTS) controllers use thyristor switching devices to provide greater control, speed and flexibility of ac transmission systems. The Thyristor Controlled Series Compensator (TCSC) is a second generation FACTS controller capable of providing fast variable compensation. This paper focuses on the variable effective fundamental equivalent reactance capability of TCSC for enhancing the transient stability.

There exists a class of control schemes for transient stability enhancement using TCSC [4-8]. In this paper, For obtaining the varying effective fundamental equivalent reactance, two different controllers namely a speed deviation based Self-tuning Fuzzy PID Controller and a nonlinear controller are taken for comparative studies. Self-tuning Fuzzy PID Controller is a speed deviation based controller and can provide a drastic improvement in transient stability. The second controller is a nonlinear controller based on feedback linearization technique. In addition to the transient stability enhancement, Self-tuning Fuzzy PID Controller

provides power oscillation damping also. The effectiveness of the controllers are demonstrated with single machine infinite bus system using MATLAB/SIMULINK software package.

2. MODEL OF ONE MACHINE-INFINITY BUS SYSTEM WITH TCSC

Consider the one machine-infinity bus system as shown in figure 1, TCSC installed in the middle of the transmission line. Source is connected to terminal voltage and is in series with the transformer. This transformer has transient reactance and is in series with two line reactance between Thyristor controlled series capacitor is arranged.

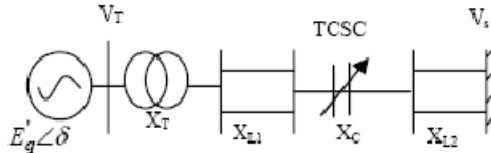

Figure 1. Diagram of one machine - infinity bus system

Assume that transient voltage of generator and the mechanical power are constant. The one machine - infinity bus system with TCSC can be described using nonlinear state equation as follows.

$$\begin{aligned} \delta' &= (\omega(t) - \omega_o) \\ \omega(t) &= \frac{\omega_o}{H} (P_m - \frac{D}{\omega_o} (\omega(t) - \omega_o) - E_q' \frac{V_s}{X_\Sigma} \sin \delta) \end{aligned} \tag{1}$$

where, $\Delta, \omega, P_m, H, D$ are power angle, rotor speed, mechanical power, rotational inertia coefficient, and damping factor of the generator.

$$X_\Sigma = X_d' + X_T + X_{L1} + X_{L2} - X_C = X_\Sigma - X_{L\Sigma} - X_C \tag{2}$$

$X_C > 0$ output is capacity reactance
 $X_C < 0$ output is inductive reactance

3. THE SELF-TUNING CONTROL PRINCIPLE OF FUZZY PID PARAMETER FOR TCSC

PID control requirements model structure very precise, and in practical applications, to different extent, most of industrial processes exist to the nonlinear, the variability of parameters and the uncertainty of model, thus using conventional PID control can not achieve the precise control of the plant. But the dependence on the mathematical model of the fuzzy control is weak, so it isn't necessary to establish the precise mathematical model of the process, and the fuzzy control has a good robustness and adaptability. According to their own characteristics, we combine fuzzy control with PID control.

Fuzzy PID parameters Self-tuning Control takes error "e" as the input of Fuzzy PID controller, meets the request of the different moments of "e" to PID parameters self-tuning. Using fuzzy control rules on-line, PID parameters "kp", "ki", "kd" are amended, Which constitute a self-tuning fuzzy PID controller, the principle of which control program as shown in Figure (2)

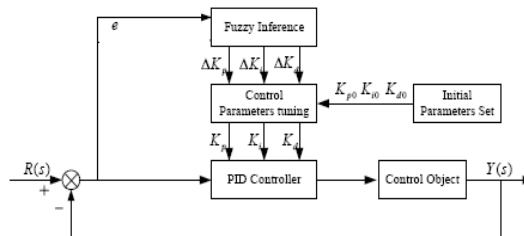

Figure 2. Self-tuning fuzzy PID controller

$$\begin{aligned}
 K_{PO} + \Delta K_P &= K_P \\
 K_{IO} + \Delta K_I &= K_I \\
 K_{DO} + \Delta K_D &= K_D
 \end{aligned}
 \tag{3}$$

Designed a parameter self-tuning PID-controller based on fuzzy control, which can adjust PID-parameters according to error. Fuzzy PID parameters Self-tuning Control takes Speed deviation.

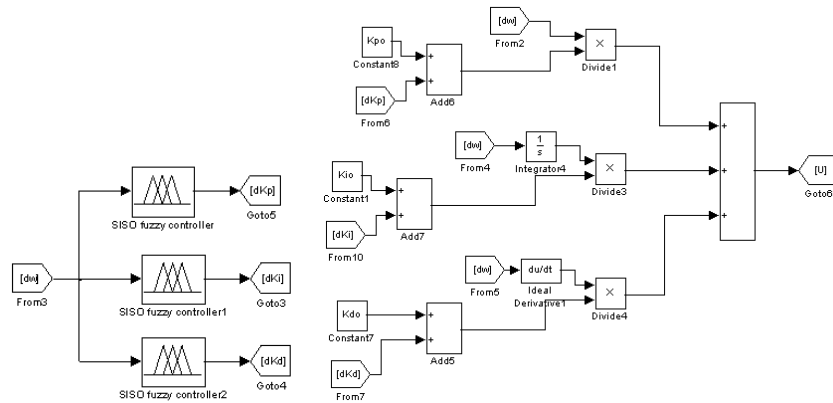

Figure 3. Block diagram of TCSC based on the self-tuning fuzzy PID control law

4. TCSC NONLINEAR CONTROLLER DESIGN USING THE PRECISE LINEARIZATION

For the system’s nonlinear equation of state (1), if it chooses the control variable

$$u = 1/X_2 \tag{4}$$

Then, (equation) can be expressed as the form of affine nonlinear system as follows:

$$\begin{bmatrix} \dot{\delta} \\ \dot{\omega} \end{bmatrix} = \begin{bmatrix} \omega - \omega_o \\ \frac{\omega_o}{H} \left(P_m - \frac{D}{\omega_o} (\omega(t) - \omega_o) \right) \end{bmatrix} + \begin{bmatrix} 0 \\ -\frac{\omega_o E' q V_s \sin \delta}{H} \end{bmatrix} u \tag{5}$$

It can be noted as follows:

$$\dot{X} = f(X) + g(X) \cdot u \tag{6}$$

Choose the coordinate transformation:

$$\begin{aligned}
 Z_1 &= \delta - \delta_o = \Delta\delta \\
 Z_2 &= \omega - \omega_o = \Delta\omega
 \end{aligned}
 \tag{7}$$

v is a new introduced variable of control input, which is designed later. The relationship of u and v is:

$$\begin{aligned}
 v &= f_2(X) + g_2(X) \cdot u \\
 u &= (f_2(X) + v) / g_2(X)
 \end{aligned}
 \tag{8}$$

Equation (7) is equal to the form of matrix:

$$\dot{Z} = A\dot{Z} + Bv$$

where,

$$A = \begin{bmatrix} 0 & 1 \\ 0 & 0 \end{bmatrix}; B = \begin{bmatrix} 0 \\ 1 \end{bmatrix}$$

According to linear quadratic optimal control theory [4], the optimal control law of the linear system (10) is:

$$V^* = -K^* Z = -K_1^* \Delta\delta - K_2^* \Delta\omega \quad (9)$$

and $K^* = R^{-1} B^T P^*$ there R is control weight coefficient, choose $R = 1$; P^* is the solution of Riccati matrix equation:

$$A^T P + P A - P B B^T P + Q = 0 \quad (10)$$

where, Q is state weight coefficient, choose

$$Q = \begin{bmatrix} 1 & 0 \\ 0 & 1 \end{bmatrix}$$

Take the matrix A , B , Q into Riccati matrix equation, solve it and P is got as below:

$$P = \begin{bmatrix} 1.732 & 1 \\ 1 & 1.732 \end{bmatrix}$$

$$\text{So } V^* = -K^* Z = -K_1^* \Delta\delta - K_2^* \Delta\omega \quad (11)$$

and according to

$$u = 1/X_{L\Sigma} = 1/(X_{L\Sigma} - X_C) \quad (12)$$

the TCSC nonlinear control law is given as follows:

$$X_C = X_{L\varepsilon} - \frac{E'_q V_s \sin \delta}{P_m + \frac{-D\Delta\omega + H(k_1^* \Delta\delta + k_2^* \Delta\omega)}{\omega_o}} \quad (13)$$

5. SIMULATIONS AND ANALYSIS OF THE SYSTEM

The one machine-infinity bus system shown in figure 1 is studied through the computer simulation using the software MATLAB/ Simulink. The related parameters and initial state of the system are given as below:

$$\begin{aligned} X_{L\varepsilon} &= 1.3, \omega_o = 18000(^{\circ}/s), H = 6.0, D = 10 \\ V_s &= 1.0, E'_q = 1.5, P_m = 1 \\ X_{co} &= 0.2 \\ \delta_o &= \arcsin \left[\frac{P_m X_{\varepsilon o}}{E'_q V_s} \right] = 47.17^{\circ} \end{aligned}$$

TCSC is described as first-order delay component variable impedance:

$$X_c = (X_c + u)/T_c \quad (14)$$

where, it chooses 3 control laws respectively to compare the simulation:

- Capacity, fixed series capacitor (FSC)
- TCSC based on PID control law

$$\Delta X_c = \Delta \omega (KP) + (KI)/S + (KD)S \quad (15)$$

The parameters of controller are given:

$$K_P = 25; K_I = 15; K_D = 1$$

b. Nonlinear control TCSC based on precise linearization method, Power angle and rotor speed are studied using digital simulation under all kinds of disturbances:

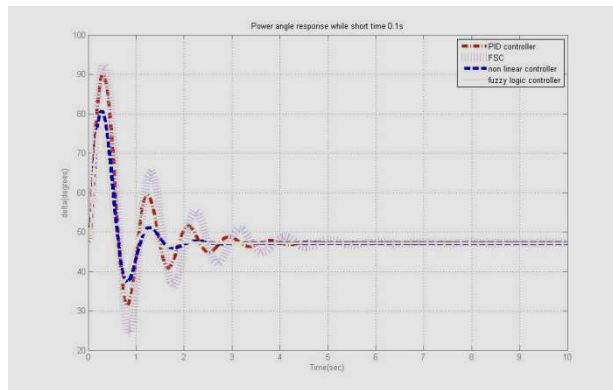

Figure 4. Power angle response while short time 0.1 s

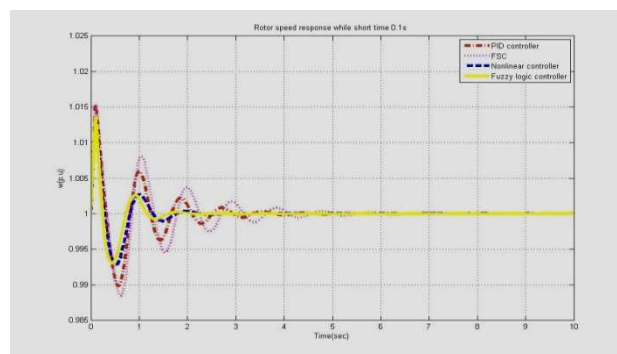

Figure 5. Rotor speed response while short time 0.1 s

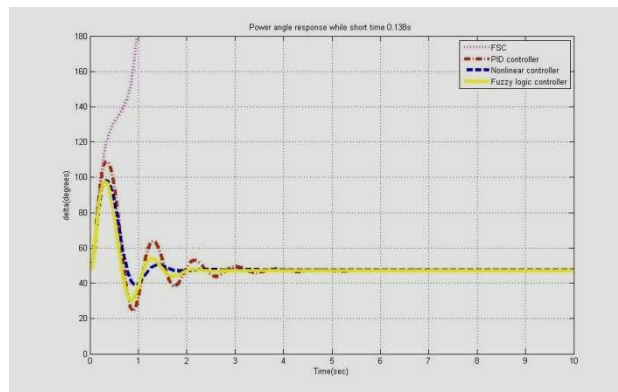

Figure 6. power angle response while short time 0.138s

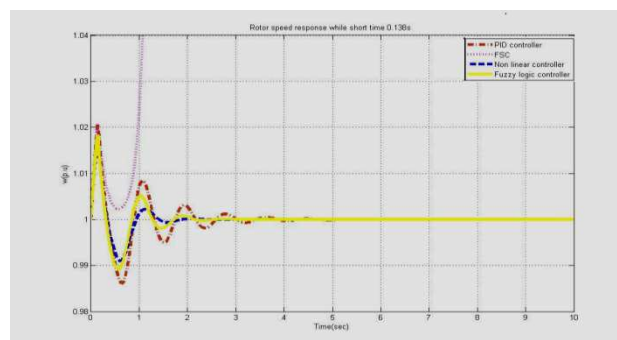

Figure 7. Rotor speed response while short time 0.138s

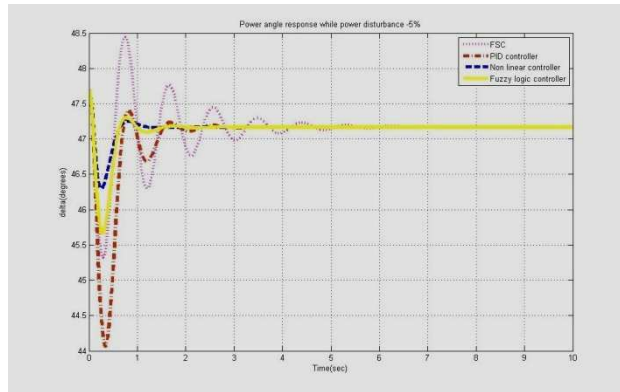

Figure 8. Power angle response while power disturbance -5%

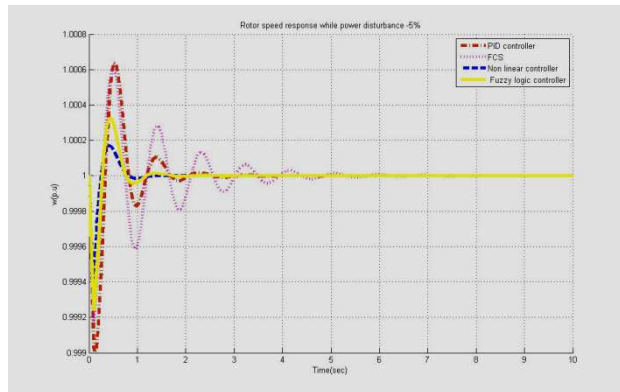

Figure 9. Rotor speed response while power disturbance -5%

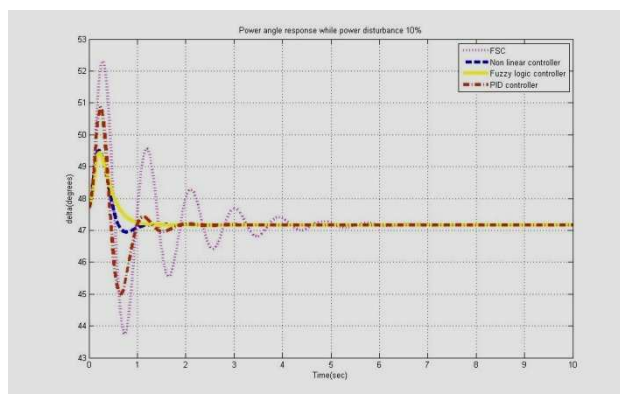

Figure 10. Power angle response while power disturbance 10%



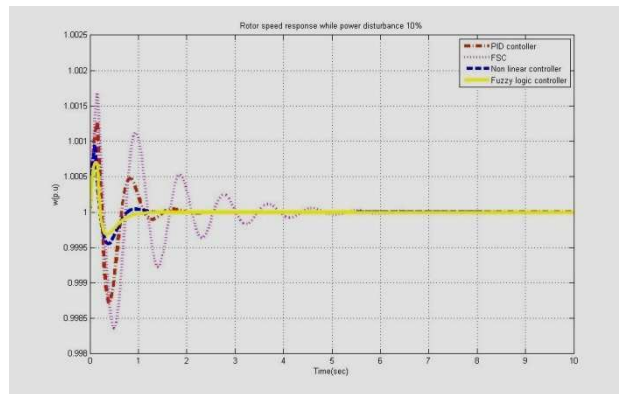

Figure 11. Rotor speed response while power disturbance 10%

- [i] At the initial time $t = 0$ sec, three phase short circuit occurs at the infinity bus, at $t = t_c = 0.1$ sec the failure is cut off;
- [ii] At the initial time $t = 0$ sec, three phase short circuit occurs at the infinity bus, $t = t_c = 0.137$ sec the failure is cut off;
- [iii] At the initial time $t = 0$ sec, it spears small power disturbance $\Delta p = -5\%$; $t = t_c = 0.1$ sec the disturbance is disappeared;
- [iv] At the initial time $t = 0$ sec, it spears small power disturbance $\Delta p = 10\%$; $t = t_c = 0.137$ sec the disturbance is disappeared; it indicates that nonlinear control TCSC can also suppress small disturbance ,large power disturbances and improve the static stability of power system, compared under the same situation, its performance is much better than two others.

6. CONCLUSION

Considering improving power system transient stability and effectively damping power oscillation as control objective, in this project in order to obtain the varying effective fundamental equivalent reactance, three different controllers selected are a simple speed deviation based conventional PID controller, nonlinear controller and Self-tuning Fuzzy PID Controller. Self-tuning Fuzzy PID Controller can not only improve the static stability of system, but also effectively damp power oscillation and enhance the transient stability of system by the computer simulation when the power system suffers small disturbance and short circuit. Simulation results show that Self-tuning Fuzzy PID Controller provides an improved transient stability and power oscillation damping compared to other controllers. In addition, it also illuminates that Self-tuning Fuzzy PID Controller is more effective than other controllers, and possess certain robustness and self-adaptability.

REFERENCES

- [1] Kimbark, E. W., "Improvement of System Stability by Switched Series Capacitors," *IEEE Transactions on Power Apparatus and System*, vol. PAS-85, No.2, pp.180-188, 1966.
- [2] Smith O. J. M., "Power System Transient Control by Capacitor Switching," *IEEE Transactions on Power Apparatus and Systems*, Vol. PAS-88, No. 1, pp.28-35, 1969.
- [3] Smith O. J. M., Webster R.H., "Series Capacitor Switching to Quench Electromechanical Transients in Power Systems," *IEEE Transactions on Power Apparatus and Systems*, vol. PAS-90, No. 2, pp. 427- 433, 1971.
- [4] Kosterev D. N., Kolodziej W. J., "Bang-Bang Series Capacitor Transient Stability Control," *IEEE Transactions on Power Systems*, vol. 10 , No. 2, pp. 915-924, 1995.
- [5] Padiyar K.R., Uma Rao K., "Discrete Control of TCSC for Stability Improvement in Power Systems," *Electrical Power and Energy Systems*, vol.19, No.5, pp.311-319, 1997.
- [6] Jiang D., Lei X., " A Nonlinear TCSC Control Strategy for Power System Stability Enhancement," *Proceedings of the 5th International Conference on Advances in Power System Control, Operation and Management*, APSCOM 2000, Hong Kong, pp 576- 580, October 2000.
- [7] Alberto D., Rosso D., "A Study of TCSC Controller Design for Power System Stability Improvement," *IEEE Transactions on Power Systems*, vol. 18, no. 4, pp. 1379-1384, November 2003.

- [8] Xiang N., Liu D., "Nonlinear Stabilized Controller Design for TCSC," *Third International Conference on Electric Utility Deregulation and Restructuring and Power Technologies*, Issue 6-9, pp.2096 – 2099, April 2008.
- [9] Kaberere K. K., Folly K. A., Petroianu A. I., "Assessment of Commercially Available Software Tools for Transient Stability: Experience Gained in an Academic Environment," *IEEE AFRICON* pp. 711-716, 2004.
- [10] Padiyar K.R., *FACTS Controllers in Power Transmission and Distribution*, New Age International (P) Ltd., 2007.
- [11] Xie Xiaorong, Jiang Qirong, *Flexible AC Transmission Systems: Principles and Applications*, Beijing: Tsinghua University Press, 2006.
- [12] Lu Qiang, Sun Yuanzhang, *Nonlinear Control of the Power System*, Version 1, Beijing: Science Press, March 1993.
- [13] Ni Yixin, Chen Shousun, Zhang Baoling, *Dynamic Power System: Theory and Analysis*, Beijing: Tsinghua University Press, 2002
- [14] Kuljaca, O., Tehjak, S., Vukic, Z., "Describing Function of Mamdani Type Fuzzy Controller with Input Signals Derived From Single System Input and Singleton Output Membership Functions," *Proceedings of the 1999 IEEE Symposium on Robotics and Control*, Hong Kong, vol. I, HmRC '99, pp. 327- 333 1999.
- [15] C.C Fuh, P.C. Tung, *Robust Stability Analysis of Fuzzy Control Systems*, *Fuzzy Sets and Systems* 88, pp 289-298, 1997.
- [16] Lj. Kuljaca, Z. Vukic, D. Donlagic, S. Telnjak, *Nonlinear Systems of Automatic Control*, Universe of Maribor, Maribor 1998.

BIOGRAPHY OF AUTHOR



Sunil was born in proddatur, anhra pradesh india, on September 17th, 1986. He is currently an assistant professor in Madanapalle Institute of Technology. He mainly researches on supervision, control and protection of power system, power electronics applications and FACTS.