

High Efficient Module of Boost Converter in PV Module

S.Daison Stallon*, K.Vinoth Kumar*, S.Suresh Kumar**

* School of Electrical Sciences, Karunya University, Coimbatore - 641114, Tamil Nadu, India

** Research Director & Professor, Department of ECE, Dr.NGP Institute of Technology, Coimbatore - 641048, Tamilnadu, India

Article Info

Article history:

Received Jul 24, 2012

Revised Oct 29, 2012

Accepted Nov 12, 2012

Keyword:

Active switch
Boost Converter
DC-AC Inverter
DC-DC Converter
PV module

ABSTRACT

Within the photovoltaic (PV) power-generation market, the PV module has shown obvious growth. However, a high voltage gain converter is essential for the module's grid connection through a dc-ac inverter. This paper proposes a converter that employs a floating active switch to isolate energy from the PV panel when the ac module is OFF; this particular design protects installers and users from electrical hazards. Without extreme duty ratios and the numerous turns-ratios of a coupled inductor, this converter achieves a high step-up voltage-conversion ratio; the leakage inductor energy of the coupled inductor is efficiently recycled to the load. These features explain the module's high-efficiency performance. The detailed operating principles and steady-state analyses of continuous, discontinuous, and boundary conduction modes are described. A 15V input voltage, 200V output voltage, and 100W output power prototype circuit of the proposed converter has been implemented; its maximum efficiency is up to 95.3% and full-load efficiency is 92.3%.

Copyright © 2012 Institute of Advanced Engineering and Science.
All rights reserved.

Corresponding Author:

K.Vinoth Kumar,
Departement of Electrical and Electronics Engineering,
School of Electrical Sciences,
Karunya University,
Coimbatore 641 114, Tamil Nadu, India.
Email: kvinoth_kumar84@yahoo.in

1. INTRODUCTION

Photovoltaic (PV) power-generation systems are becoming increasingly important and prevalent in distribution generation systems. A conventional centralized PV array is a serial connection of numerous panels to obtain higher dc-link voltage for main electricity through a dc-ac inverter. The total power generated from the PV array is sometimes decreased remarkably when only a few modules are partially covered by shadows, thereby decreasing inherent current generation, and preventing the generation current from attaining its maximum value on the array. To overcome this drawback, an ac module strategy has been proposed. In this system, a low-power dc-ac utility interactive inverter is individually mounted on PV module and operates so as to generate the maximum power from its corresponding PV module.[1]

The power capacity range of a single PV panel is about 100W to 300W, and the maximum power point (MPP) voltage range is from 15V to 40V, which will be the input voltage of the ac module; in cases with lower input voltage, it is difficult for the ac module to reach high efficiency. However, employing a high step-up dc-dc converter in the front of the inverter improves power-conversion efficiency and provides a stable dc link to the inverter. The micro inverter includes dc-dc boost converter, dc-ac inverter with control circuit as shown in Fig. 1. The dc-dc converter requires large step-up conversion from the panel's low voltage to the voltage level of the application. The dc-input converter must boost the 48 V of the dc bus voltage to about 380-400 V. Generally speaking, the high step-up dc-dc converters for these applications have the following common features:

- 1) High step-up voltage gain. Generally, about a ten fold step-up gain is required.
- 2) High efficiency.
- 3) No isolation is required.[2]

There are two major concerns related to the efficiency of a high step-up dc-dc converter: large input current and high output voltage.

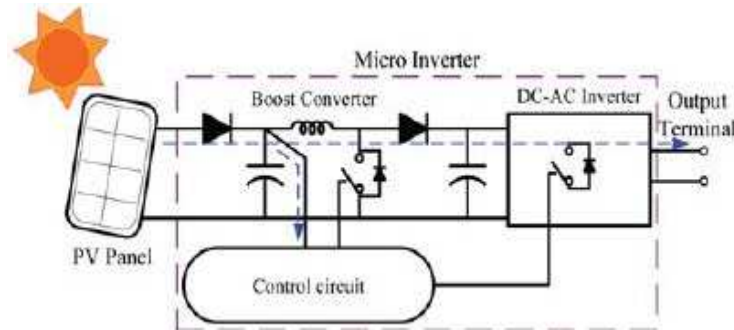

Figure .1 Block diagram of the whole system

Fig. 1 shows the solar energy through the PV panel and micro inverter to the output terminal when the switches are OFF.[3] When installation of the ac module is taking place, this potential difference could pose hazards to both the worker and the facilities. A floating active switch is designed to isolate the dc current from the PV panel, for when the ac module is off-grid as well as in the non operating condition. This isolation ensures the operation of the internal components without any residential energy being transferred to the output or input terminals, which could be unsafe.

2. APPLICATIONS OF DC-DC HIGH STEP UP CONVERTER

2.1 DC-DC Converters

As an example for a high intensity discharge (HID) lamp ballast used in automotive head lamps in which the start-up voltage is up to 400V, another example diagram shows the convergence of computer and telecommunications industries in that the dc-input converter must boost the 48V of the dc bus voltage to about 380-400V. [4] The main aim here is to attain the maximum output as much we can get from the dc input similarly in this paper from the pv panel we can the dc voltage as output before connecting the output to grid the voltage from the pv panel is not more sufficient since in between the pv panels and the grid interface we are going for micro inverter which consists of boost converter and inverter. The simulation result in this paper uses 15V input to the boost converter and attains 55.64V as the output voltage respectively [5].

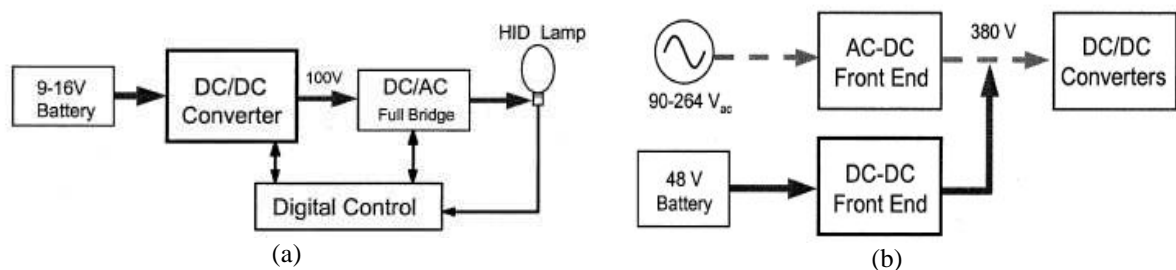

Figure .2 applications of the dc-dc converter a) HID lamp ballast b) dual-input front –end converters.

2.2. Proposed Converter to Attain High Efficiency

The proposed converter, shown in Fig.3, is comprised of a coupled inductor $T1$ with the floating active switch $S1$. The primary winding $N1$ of a coupled inductor $T1$ is similar to the input inductor of the conventional boost converter, and capacitor $C1$ and diode $D1$ receive leakage inductor energy from $N1$. The secondary winding $N2$ of coupled inductor $T1$ is connected with another pair of capacitors $C2$ and diode $D2$,

which are in series with $N1$ in order to further enlarge the boost voltage. The rectifier diode $D3$ connects to its output capacitor $C3$. The proposed converter has several features:

- 1) The connection of the two pairs of inductors, capacitor, and diode gives a large step-up voltage-conversion ratio;
- 2) The leakage-inductor energy of the coupled inductor can be recycled, thus increasing the efficiency and restraining the voltage stress across the active switch; and 3) the floating active switch efficiently isolates the PV panel energy during non operating conditions, which enhances safety. Before get into the connection procedure we should know about the characteristics and functions of the pv panels then only it is very easy to get the maximum power output from the PV panels.[6]

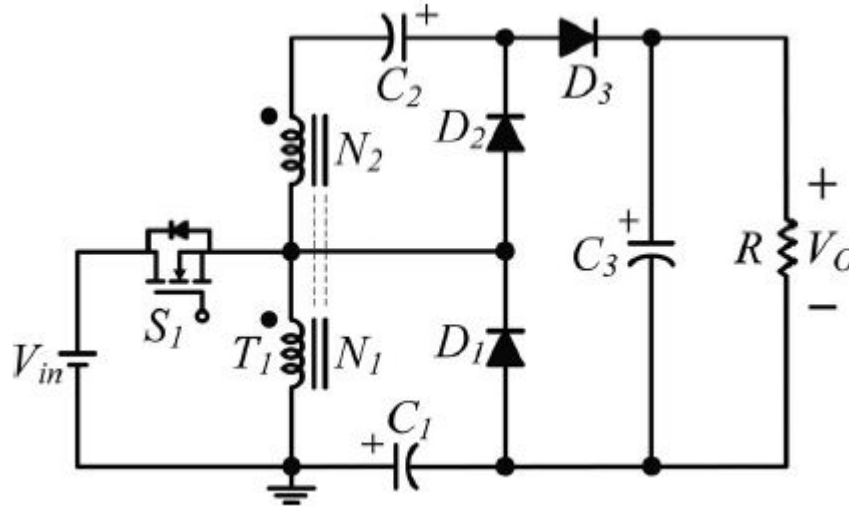

Figure .3 Proposed Converter

2.3 Demands Defined By the PV Modules

Figure 4(a) model and characteristics of PV panel Electrical model with current and voltages (b) Electrical characteristic of the PV cell, exposed to a given amount of (sun) light at a given temperature. As indicated, ripple at the PV module’s terminals results in a somewhat lower power generation, compared with the case where no ripple is present at the terminals. A model of a PV cell is sketched in Fig. 4(a), and its electrical characteristic is illustrated in Fig. 4(b).[3] The most common PV technologies nowadays are the mono crystalline and the multi crystalline-silicon modules, which are based on traditional, and expensive, microelectronic manufacturing processes .

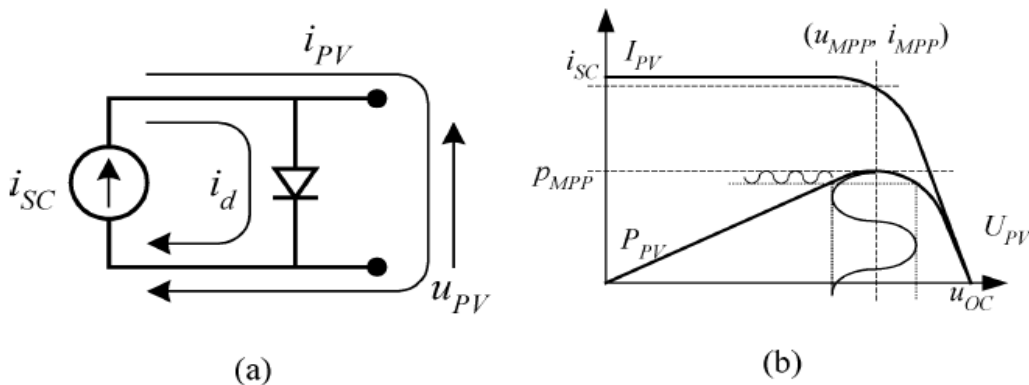

Figure .4 Model and Characteristics of PV Panel

The MPP voltage range for these PV modules is normally defined in the range from 23 to 38 V at a power generation of approximate 160 W, and their open-circuit voltage is below 45 V. [7] However, new technologies like thin-layer silicon, amorphous-silicon, and Photo Electro Chemical (PEC) are in

development. These types of PV modules can be made arbitrarily large by an inexpensive “roll-on–roll-off” process. This means that new modules with only one cell may see the light in the future. The voltage range for these cells/modules is located around 0.5 1.0 V at several hundred amperes per square meter cell . The inverters must guarantee that the PV module(s) is operated at the MPP, which is the operating condition where the most energy is captured. This is accomplished with an MPP tracker (MPPT). It also involves the ripple at the terminals of the PV module(s) being sufficiently small, in order to operate around the MPP without too much fluctuation [8].

3 SIMULATION RESULTS

3.1 Simulation of Boost Converter

The simulation results are shown in the figure.5, the simulation diagram and the simulation output results separately shown for the boost converter as well as inverter .The parameter values is shown below $V_s=15\text{ V}$, $L=1\text{e}^{-3}\text{ H}$, $C_1 = C_2 = 47\text{e}^{-6}\text{ F}$, $C_3= 220\text{e}^{-6}\text{ F}$, $R_{\text{load}} = 400\text{ ohms}$, $V_o=56\text{ V}$. Figure 5 shows the simulation of Boost Converter using Matlab Simulink, it consists of the DC voltage source input, MOSFET switch, 2 inductors, 3 diodes, 3 capacitors and a load the voltage measurement connected with scope to verify the simulation output results and with the signal generator to give the pulses for the circuit and finally the power GUI is connected. The main concern of this project is to design and construct a DC to DC converter which is one of the main module in the solar PV system that shown in Figure. The main idea of the DC to DC converter is based on boost type. The purpose of the project is to develop DC to DC converter (boost type) that converts the unregulated DC input to a controlled DC output with desired voltage level. The main objectives of this project are designing and constructing a DC to DC converter (boost type) circuit practically with input voltage, 15 V and the output voltage, 56 V. The output voltage waveform is shown in Figure 6 [9].

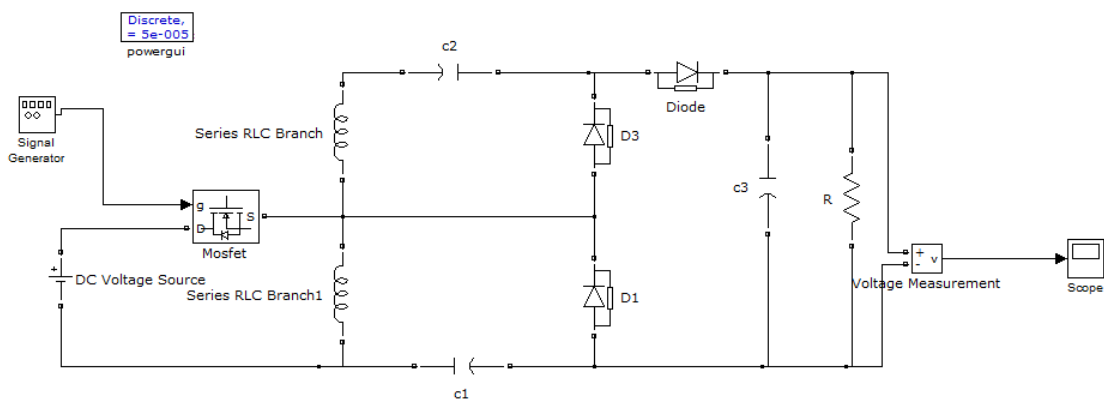

Figure 5. Simulation of Boost Converter using Matlab/Simulink



Figure .6 Output Voltage waveform of Boost Converter

Figure 7 shows the simulation of Single phase full bridge Inverter using Matlab simulink, When the S_1 and S_2 conducts the load voltage is V_s where as the S_3 and S_4 conducts the load voltage is $-V_s$. Frequency of the output voltage can be controlled by varying the periodic time T . The circuit connected with the RL load, in the circuit there are 4 IGBTs. The basic working principle of the inverter is to convert the dc power into ac power at desired output voltage and frequency. The inverters are mainly classified into two types 1) voltage source inverters 2) current source inverters. In the above circuit it uses voltage source inverters. The voltage source inverter is the one in which the dc source has small or negligible impedance. In other words, voltage source inverter has stiff dc voltage source at its input terminals. The output voltage and output current waveforms are shown in Figure 8 & Figure 9 [10].

3.2 Simulation of Single Phase Full Bridge Inverter

The parameter values is shown below:

$$V_{dc} = 56 \text{ V}$$

Pulse generator:

$$\text{Amplitude} = 1 \text{ V}$$

$$\text{Period (secs)} = 0.02 \text{ sec}$$

$$\text{Pulse width(\% of period)} = 50\%$$

$$\text{Phase delay(secs)}=0$$

Load:

$$R_{\text{load}} = 1 \text{ ohms}$$

$$L_{\text{load}} = 10e^{-3} \text{ H}$$

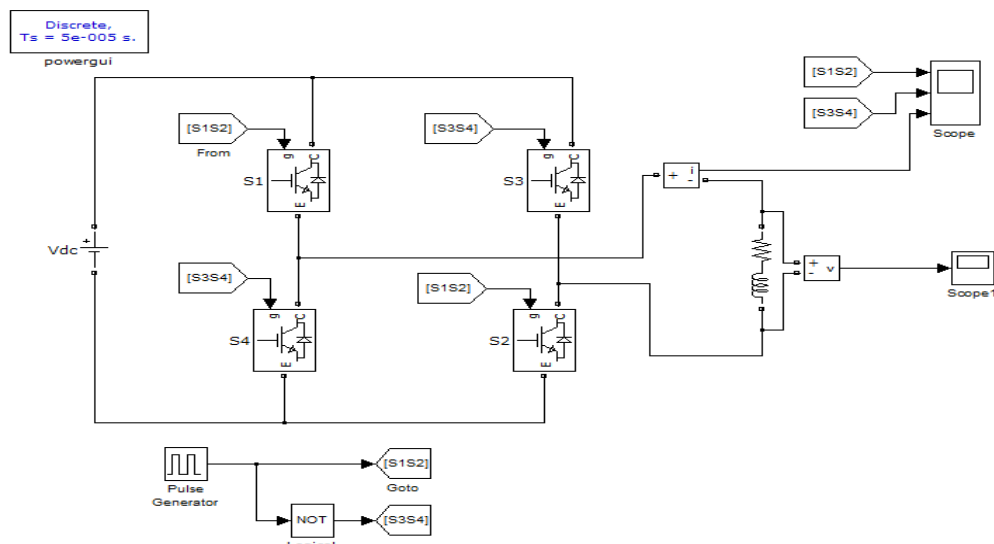

Figure .7 Simulation of Single Phase Full Bridge Inverter using Matlab/Simulink

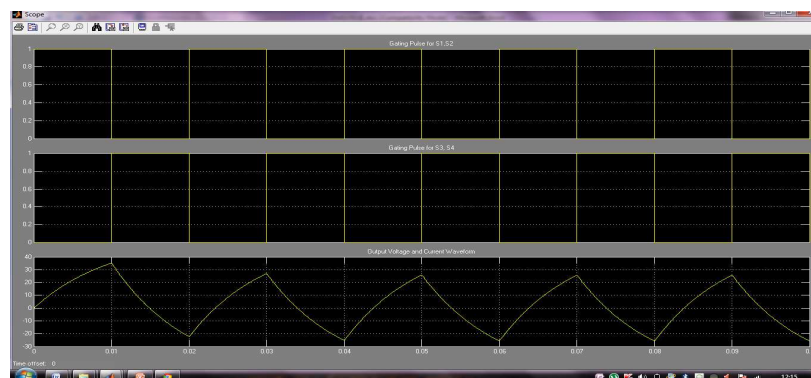

Figure 8. Pulse voltage and Output Current waveform for Single Phase Full Bridge Inverter

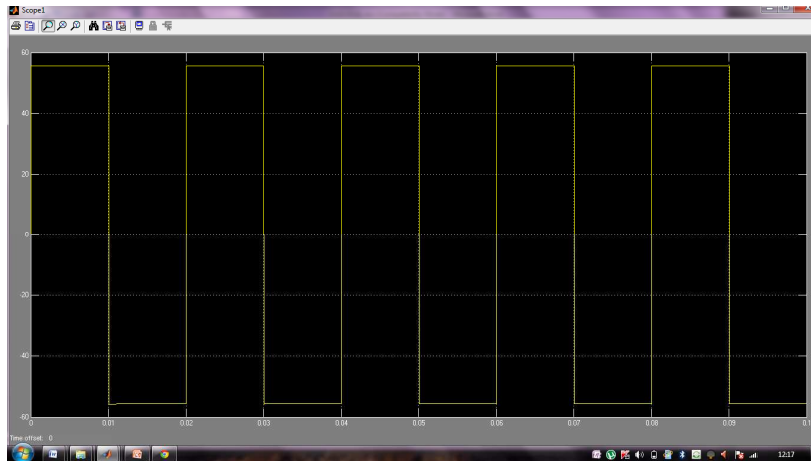

Figure 9. Output Voltage waveform for Single Phase Full Bridge Inverter

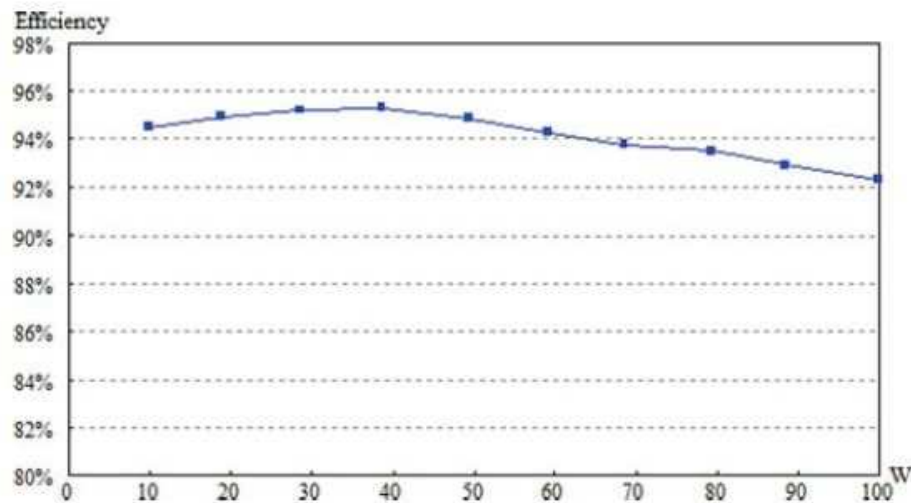

Figure 10. Maximum Efficiency of Proposed Converter

Figure 10 shows that the maximum efficiency of 95.3% occurred at 40% of full load; and the full-load efficiency is maintained at 92.3%. The efficiency variation is about 3%, and the flat efficiency curve is able to yield higher energy from the PV module during periods when sunlight is fading. The residential voltage discharge time of the proposed converter is 480 milliseconds, which prevents any potential electrical injuries to humans [11-12].

4. CONCLUSION

Since the energy of the coupled inductor's leakage inductor has been recycled, the voltage stress across the active switch S_1 is constrained, which means low ON-state resistance $R_{DS(ON)}$ can be selected. Thus, improvements to the efficiency of the proposed converter have been achieved. The switching signal action is performed well by the floating switch during system operation; on the other hand, the residential energy is effectively eliminated during the non operating condition, which improves safety to system technicians. From the prototype converter, the turns ratio $n = 5$ and the duty ratio D is 55%; thus, without extreme duty ratios and turns ratios, the proposed converter achieves high step-up voltage gain, of up to 13 times the level of input voltage. The experimental results show that the maximum efficiency of 95.3% is measured at half load, and a small efficiency variation will harvest more energy from the PV module during fading sunlight.

REFERENCES

- [1] T. Shimizu, K. Wada, and N. Nakamura, "Flyback-type single-phase utility interactive inverter with power pulsation decoupling on the dc input for an ac photovoltaic module system," *IEEE Transactions on Power Electronics*, vol. 21, no. 5, pp. 1264–1272, January 2006.
- [2] C. Rodriguez and G. A. J. Amaratunga, "Long-lifetime power inverter for photovoltaic ac modules," *IEEE Trans. Industrial Electronics*, vol. 55, no. 7, pp. 2593–2601, July 2008.
- [3] S. B. Kjaer, J. K. Pedersen, and F. Blaabjerg, "A review of single-phase grid-connected inverters for photovoltaic modules," *IEEE Trans. Industrial Applications*, vol. 41, no. 5, pp. 1292–1306, September 2005.
- [4] J. J. Bzura, "The ac module: An overview and update on self-contained modular PV systems," in *Proceedings of IEEE Power Engineering Society Generation Meeting*, pp. 1–3, July 2010.
- [5] B. Jablonska, A. L. Kooijman-van Dijk, H. F. Kaan, M. van Leeuwen, G. T. M. de Boer, and H. H. C. de Moor, "PV-PRIVE project at ECN, five years of experience with small-scale ac module PV systems," in *Proceedings of 20th European Photovoltaic Solar Energy Conference*, Barcelona, Spain, pp. 2728–2731, June 2005.
- [6] T. Umeno, K. Takahashi, F. Ueno, T. Inoue, and I. Oota, "A new approach to low ripple-noise switching converters on the basis of switched-capacitor converters," in *Proc. IEEE International Symposium Circuits Systems*, pp. 1077–1080, July 1991.
- [7] B. Axelrod, Y. Berkovich, and A. Ioinovici, "Switched-capacitor/ switched-inductor structures for getting transformerless hybrid dc–dc PWM converters," *IEEE Transactions on Circuits Systems*, vol. 55, no. 2, pp. 687–696, March 2008.
- [8] B. Axelrod, Y. Berkovich, and A. Ioinovici, "Transformerless dc–dc converters with a very high dc line-to-load voltage ratio," in *Proc. IEEE International Symposium Circuits Systems (ISCAS)*, 2003, vol. 3, pp. 435–438, 2003.
- [9] H. Chung and Y. K. Mok, "Development of a switched-capacitor dc–dc boost converter with continuous input current waveform," *IEEE Transactions on Circuits Systems, Appl.*, vol. 46, no. 6, pp. 756–759, June 1999.
- [10] T. J. Liang and K. C. Tseng, "Analysis of integrated boost-flyback step-up converter," *IEE Proceedings of Electrical Power Applications*, vol. 152, no. 2, pp. 217–225, March 2005.
- [11] Q. Zhao and F. C. Lee, "High-efficiency, high step-up dc–dc converters," *IEEE Transaction on Power Electronics*, vol. 18, no. 1, pp. 65–73, January 2003.
- [12] M. Zhu and F. L. Luo, "Voltage-lift-type cuk converters: Topology and analysis," *IET Power Electron.*, vol. 2, no. 2, pp. 178–191, Mar. 2009.
- [13] J. W. Baek, M. H. Ryoo, T. J. Kim, D. W. Yoo, and J. S. Kim, "High boost converter using voltage multiplier," in *Proceedings of IEEE Industrial Electronics Society Conference (IECON)*, pp. 567–572, 2005.
- [14] J. Xu, "Modeling and analysis of switching dc–dc converter with coupled inductor," in *Proceedings of IEEE 1991 Int. Conf. Circuits Systems (CICCAS)*, pp. 717–720, 1991.
- [15] J. Wai, C. Y. Lin, R. Y. Duan, and Y. R. Chang, "High-efficiency dc–dc converter with high voltage gain and reduced switch stress," *IEEE Transactions on Industrial Electronics*, vol. 54, no. 1, pp. 354–364, February 2007.
- [16] S. M. Chen, T. J. Liang, L. S. Yang, and J. F. Chen, "A cascaded high step-up dc–dc converter with single switch for microsource applications," *IEEE Transactions on Power Electronics*, vol. 26, no. 4, pp. 1146–1153, April 2011.
- [17] L. S. Yang and T. J. Liang, "Analysis and implementation of a novel bidirectional dc–dc converter," *IEEE Trans. Industrial Electronics*, vol. 59, no. 1, pp. 422–434, January 2012.
- [18] W. Li and X. He, "Review of non-isolated high-step-up dc/dc converters in photovoltaic grid-connected applications," *IEEE Transactions on Industrial Electronics*, vol. 58, no. 4, pp. 1239–1250, April 2011.
- [19] S. H. Park, S. R. Park, J. S. Yu, Y. C. Jung, and C. Y. Won, "Analysis and design of a soft-switching boost converter with an HI-Bridge auxiliary resonant circuit," *IEEE Trans. Power Electron.*, vol. 25, no. 8, pp. 2142–2149, Aug. 2010.
- [20] G. Yao, A. Chen, and X. He, "Soft switching circuit for interleaved boost converters," *IEEE Transactions on Power Electronics*, vol. 22, no. 1, pp. 80–86, January 2007.
- [21] Y. Park, S. Choi, W. Choi, and K. B. Lee, "Soft-switched interleaved boost converters for high step-up and high power applications," *IEEE Transactions on Power Electronics*, vol. 26, no. 10, pp. 2906–2914, October 2011.
- [22] Y. Zhao, W. Li, Y. Deng, and X. He, "Analysis, design, and experimentation of an isolated ZVT boost converter with coupled inductors," *IEEE Transactions on Power Electronics*, vol. 26, no. 2, pp. 541–550, February 2011.
- [23] H. Mao, O. Abdel Rahman, and I. Batarseh, "Zero-voltage-switching dc–dc converters with synchronous rectifiers," *IEEE Transactions on Power Electronics*, vol. 23, no. 1, pp. 369–378, January 2008.
- [24] J. M. Kwon and B. H. Kwon, "High step-up active-clamp converter with input-current doubler and output-voltage doubler for fuel cell power systems," *IEEE Transactions on Power Electronics*, vol. 24, no. 1, pp. 108–115, January 2009.
- [25] S. Dwari and L. Parsa, "An efficient high-step-up interleaved dc–dc converter with a commonactive clamp," *IEEE Transactions on Power Electronics*, vol. 26, no. 1, pp. 66–78, January 2011.
- [26] C. Restrepo, J. Calvente, A. Cid, A. El Aroudi, and R. Giral, "A noninverting buck-boost dc–dc switching converter with high efficiency and wide bandwidth," *IEEE Transactions on Power Electronics*, vol. 26, no. 9, pp. 2490–2503, September 2011.
- [27] K. B. Park, G. W. Moon, and M. J. Youn, "Nonisolated high step-up boost converter integrated with sepic converter," *IEEE Transactions on Power Electronics*, vol. 25, no. 9, pp. 2266–2275, September 2010.

- [28] L. S. Yang, T. J. Liang, and J. F. Chen, "Transformerless dc–dc converters with high step-up voltage gain," *IEEE Transaction on Industrial Electronics.*, vol. 56, no. 8, pp. 3144–3152, August 2009.
- [29] N. Pogaku, M. Prodanovic, and T. C. Green, "Modeling, analysis and testing of autonomous operation of an inverter-based microgrid," *IEEE Transactions on Power Electronics.*, vol. 22, no. 2, pp. 613–625, March 2007.

BIOGRAPHIES OF AUTHORS



S. Daison Stallon received his B.E. degree in Electrical and Electronics Engineering from Anna University, Coimbatore, Tamil Nadu, India. Presently he is pursuing M.Tech in Renewable Energy Technologies from Karunya University, Coimbatore, Tamil Nadu, India.



K. Vinoth Kumar received his B.E. degree in Electrical and Electronics Engineering from Anna University, Chennai, Tamil Nadu, India. He obtained M.Tech in Power Electronics and Drives from VIT University, Vellore, Tamil Nadu, India. Presently he is working as an Assistant Professor in the School of Electrical Science, Karunya Institute of Technology and Sciences (Karunya University), Coimbatore, Tamil Nadu, India. He is pursuing PhD degree in Karunya University, Coimbatore, India. His present research interests are Condition Monitoring of Industrial Drives, Neural Networks and Fuzzy Logic, Special machines, Application of Soft Computing Technique. He has published various papers in international journals and conferences and also published four textbooks. He is a member of IEEE (USA), MISTE and also in International association of Electrical Engineers (IAENG).



Dr. S. Suresh Kumar received his B.E. degree in Electrical and Electronics Engineering from Bharathiar University, Coimbatore, Tamil Nadu, India in 1992. He has obtained M.E. from Bharathiar University, Coimbatore, Tamil Nadu, India in 1997. He has received doctoral degree from Bharathiar University, Coimbatore, Tamil Nadu, India in 2007. Presently he is working as a Professor and Head of the department for Electrical and Electronics Engineering in Karunya Institute of Technology and Sciences (Karunya University), Coimbatore, Tamil Nadu, India. He is having 17 years of teaching experience from PSG College of technology. His present research interests are Electrical Machines and Power Quality. He has already published 107 papers in international journals and international conferences. He is a member of IEEE (USA), ASE, ISCA, MCSI, and MISTE and also in International association of Electrical Engineers.