

## A novel efficient adaptive-neuro fuzzy inference system control based smart grid to enhance power quality

Dharamalla Chandra Sekhar<sup>1,2</sup>, Pokanati Veera Venkata Rama Rao<sup>3</sup>, Rachamadugu Kiranmayi<sup>1</sup>

<sup>1</sup>Department of Electrical and Electronics Engineering, Jawaharlal Nehru Technological University Anantapur, Ananthapuramu, India

<sup>2</sup>Department of Electrical and Electronics Engineering, Malla Reddy Engineering College (A), Maisammaguda, India

<sup>3</sup>Department of Electrical and Electronics Engineering, Maturi Venkata Subba Rao Engineering College, Hyderabad, India

### Article Info

#### Article history:

Received May 13, 2020

Revised Mar 13, 2022

Accepted Mar 26, 2022

#### Keywords:

Adaptive-neuro fuzzy inference system controller

MATLAB/Simulink

Maximum power point tracking

Power quality

PV-wind-grid integration

Smart grid

### ABSTRACT

A novel adaptive-neuro fuzzy inference system (ANFIS) control algorithm-based smart grid to solve power quality issues is investigated in this paper. To improve the steady-state and transient response of the solar-wind and grid integrated system proposed ANFIS controller works very well. Fuzzy maximum power point tracking (MPPT) algorithm-based DC-DC converters are utilized to extract maximum power from solar. A permanent magnet synchronous generator (PMSG) is employed to get maximum power from wind. To maximize both power generations, back-to-back voltage source converters (VSC) are operated with an intelligent ANFIS controller. Optimal power converters are adopted this proposed methodology and improved the overall performance of the system to an acceptable limit. The simulation results are obtained for a different mode of smart grid and non-linear fault conditions and the proven proposed control algorithm works well.

*This is an open access article under the [CC BY-SA](https://creativecommons.org/licenses/by-sa/4.0/) license.*



### Corresponding Author:

Dharamalla Chandra Sekhar

Department of Electrical and Electronics Engineering, Jawaharlal Nehru Technological University

Ananthapur

Ananthapuramu, Andhra Pradesh, India

Email: [daram.sekhar@gmail.com](mailto:daram.sekhar@gmail.com)

## 1. INTRODUCTION

In recent years the usage of renewable energy sources (RES) is popular over traditional fossil fuel-based energy sources like hydro and thermal. RES sources are free from air pollutants (eco-friendly), with more reliability and optimum cost. Extract maximum power from solar different MPPT algorithms are proposed in the literature such as perturb and observe [1], incremental conductance (IC), fuzzy intelligent Maximum power point tracking (MPPT) [2]. In this paper to get maximum power from photovoltaic (PV), the fuzzy MPPT technique is adopted. Maximum power extracted from the wind with tip-speed ratio control, lower relationship-based, perturbation and observation (P&O), hybrid control [3] and intelligent control strategies [4], [5] based techniques like neural, fuzzy, and adaptive-neuro fuzzy inference system (ANFIS). Stand-alone integrated hybrid power sources [6], [7] are modeled and controlled well to satisfy the load demand [8]–[10]. It is further extended to dynamic energy management between the RES sources is proposed with conventional control techniques.

After doing a literature review, it was discovered that ANFIS is a popular controller due to its simplicity. As previously stated, it is frequently employed in power system applications. The filter parameter is the most difficult aspect of the ANFIS design. In real-time practice, this filter parameter is tuned based on the user's requirements. We know that the advanced control state feedback control strategy is more versatile, allowing for optimal design [11]–[14].

A blend of neural and fuzzy rationale procedures offers to take care of issues and challenges in the plan fuzzy have been executed by [15]. The new methodology in the design of the neural organization is known as a recurrent neural network (RNN) which is an improvement over the current controllers and actualized in [16]. The yield of a dynamic framework is a component of a past yield or previous information or both, thusly recognizable proof and control of dynamic framework are an inborn errand contrasted with static framework [16]–[21]. The feed forward neural fuzzy organizations have a significant downside so their application is restricted to static planning issues [22]–[27]. In this way, to recognize dynamic frameworks, repetitive neuro fuzzy organizations ought to be utilized. A Takagi–Sugeno–Kang (TSK)-type intermittent fuzzy organization is intended for dynamic frameworks.

In light of audit, it is presumed that the motions in the dynamic power frameworks can be damped by the versatile fuzzy controller [28]. The exploration work is done to check the presentation of FACTS gadgets for upgrading framework execution. The ANFIS controller is proposed for power stabilizer. The proportional integral derivative (PID), as ANFIS controller boundaries are prepared by particle swarm optimization (PSO) in [29], [30]. The ANFIS can be made as self-learning controller utilizing iterative learning strategy clarified. Developmental calculations are equal and worldwide pursuit methods. Since they all the while assess numerous focuses in the inquiry space, they are bound to unite toward the worldwide arrangement clarified.

The next sections of this article are composed as system configuration PV wind integrated grid in section 2. Proposed ANFIS control scheme in section 3. MATLAB environmental based simulation results are presented in section 4 and concluded in section 5.

## 2. SYSTEM CONFIGURATION

The model of grid integrated solar-wind smart grid system depicts in Figure 1. Smart grid systems include several critical qualities, including performance optimization, system dependability, and operational efficiency. A unique model of a smart grid-connected PV/WT hybrid system is created in this paper. Photovoltaic array, wind turbine, asynchronous (induction) generator, controller, and converters are all part of the system. The model is created with the help of the MATLAB/Simulink software suite. Based on the development of a MPPT, the P&O technique is utilized to maximize the generated power. The proposed model's dynamic behavior is investigated under various operating situations.

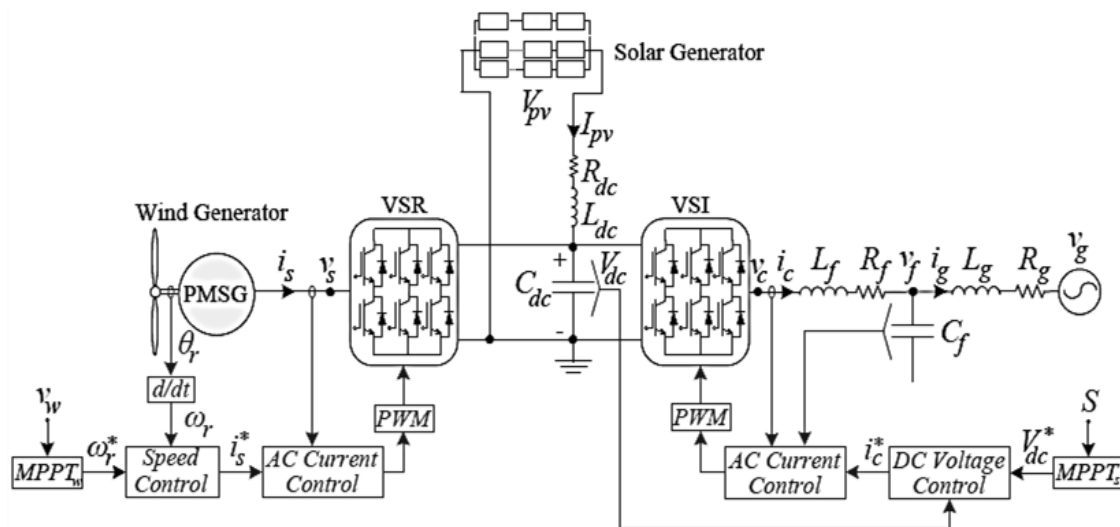

Figure 1. Model of proposed PV-wind integrated grid

### 2.1. Design of PV cell

A current source in shunt with a diode and two resistors linked anti parallel to each other describe the architecture of a solar cell in general. The power production of solar cells is controlled by these resistors as shown in Figure 2. Both the n-type and p-type sides of the solar cell have ohmic metal-semiconductor connections, and the electrodes are coupled to an external load. Electrons produced on the n-type side, or p-type electrons “caught” by the junction and swept onto the n-type side, may flow through the wire, power

the load, and continue through the wire until they reach the p-type semiconductor-metal contact. They recombine with a whole formed on the p-type side of the solar cell as an electron-hole pair, or a hole swept across the junction from the n-type side after being created there. The voltage measured is equal to the difference between the quasi-Fermi levels of the majority carriers (electrons in the n-type section and holes in the p-type portion) at the two terminals.

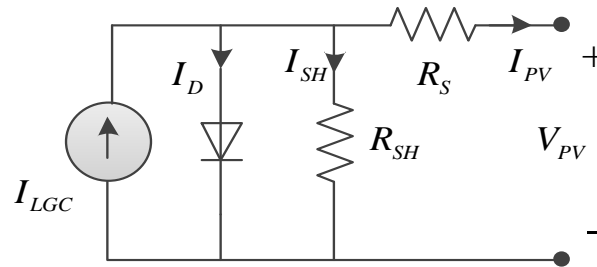

Figure 2. Representation diagram of PV cell

To obtain the required output voltage and current from a PV panel, n number of PV panels is connected in series-parallel configurations, and the voltage and current are stated mathematically;

$$V_{series} = \sum_{j=1}^n V_j = V_1 + V_2 + \dots + V_n \tag{1}$$

$$V_{seriesoc} = \sum_{j=1}^n V_j = V_{oc1} + V_{oc2} + \dots + V_{ocn} \text{ for } I = 0 \tag{2}$$

$$I_{parallel} = \sum_{j=1}^n I_j = I_1 + I_2 + \dots + I_n \tag{3}$$

$$V_{parallel} = V_1 = V_2 = \dots = V_n \tag{4}$$

By default, bypass diodes are used in solar panels to reduce overvoltage in the system. However, it raises the expense of the system.

**2.2. DC-DC converters**

In general, regulating, switching series voltage-source converter (VSC) converters by duty ratio expose for optimal performance, switches with some delay cause stress on the switches as well as the converters' life time in DC-DC converters, and PV panels produce less power. To get the maximum power output of the PV module, a fuzzy MPPT algorithm is now used to manage the switching pattern. DC-DC converters with fuzzy logic give the PS network's dynamic performance and overall efficiency are improved by this fuzzy logic controller (FLC) based direct current (DC) converter, which supplies less oscillating voltage to the series VSCs.

**2.3. Design of permanent magnetic synchronous based wind energy**

Because the permanent magnetic synchronous generator (PMSG) is a brushless DC machine, it has a simple and durable design. When compared to the doubly fed induction generator (DFIG) generator, it is less expensive. By adjusting terminal voltages of the PMSG's rotor circuit, it regulates the actual, reactive power of the wind energy conversion system (WECS) system. As a result, it regulates power factor of the entire WECS. PMSG is used to accomplish desired speed management without the need of slip rings. Mathematically PMSG represents in dq0 axis:

$$V_{gq} = (R_g + p \cdot L_q) \cdot i_q + \omega_e \cdot L_d \cdot i_d \tag{5}$$

$$V_{gd} = (R_g + p \cdot L_d) \cdot i_d - \omega_e \cdot L_q \cdot i_q \tag{6}$$

where  $V_{gd}$  and  $V_{gq}$  represents the stator voltages in direct and quadrature axis.

$$T_e = \frac{3}{2} P n [\varphi + i_q - (L_d - L_q) i_d i_q] \tag{7}$$

If  $i_d=0$ , the electromagnetic torque is expressed as in (8).

$$T_e = \frac{3}{2} P_n \psi f i q \tag{8}$$

The dynamic equation of wind turbine is described by (9).

$$J \frac{d\omega_m}{dt} = T_e - T_m - F W m \tag{9}$$

### 3. CONTROL SCHEME

The implementation of FLC based voltage source inverters (VSI) is comparable to the FLC MPPT method. This mistake is treated as a collection of fuzzily defined rules. By selecting rules, membership function, and de-fuzzification as shown in Figure 3. These fuzzy sets provide proportional integral (PI) control settings. Table 1 and Figure 4. Membership function for Figure 4(a) error, Figure 4(b) change in error, and Figure 4(c) output lists the set of fuzzy rules. The fuzzy logic reasoning differs from traditional multi-valve legitimate frame works in both concept and substance, such as negative big (NB), negative small (NS), zero (Z), positive big (PB), and positive small (PS). The actual value of voltage across ( $V_{d\text{cact}}$ ) point of Coupling is contrast with reference DC voltage ( $V_{dc}$ ) that error is optimized with fuzzification then error is rectified send to the system after de-fuzzification.

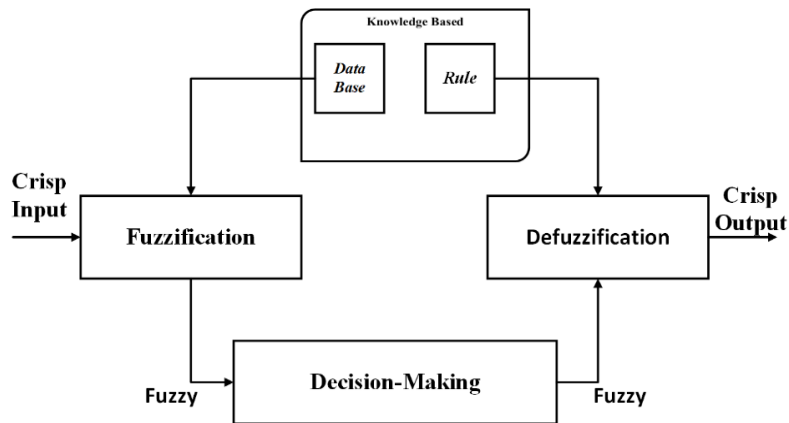

Figure 3. Fuzzy inference system

Table 1. Fuzzy rule set

		Error (E)						
		NB	NM	NS	Z	PS	PM	PB
Change in Error ( $\Delta E$ )	NB	NB	NB	NB	NS	NS	NS	Z
	NS	NB	NM	NS	NS	Z	PS	PS
	Z	NS	NM	NS	Z	PS	PM	PM
	PS	NS	NS	Z	PS	PM	PB	PB
	PB	Z	NB	PS	PS	PB	PS	PB

#### 3.1. ANFIS based VSI controller design

The control method for operating VSC using an ANN and fuzzy based PV system is presented in Figure 5(a). These approaches give various tuning heuristics and thumb rules for PI controllers for VSC soft switching. The simplification of higher order transfer functions into lower order estimates is common in several of these techniques. Guarantee that the tuning given by these methodologies will result in adequate presentation for all systems, as with any intelligent-based strategy. Five layers are considered in the creation of this ANN human brain network. Layer 1 has 25 neurons, layers 2-4 have 16 neurons, and the 5<sup>th</sup> layer has 2 neurons, as illustrated in Figure 5(b). The allowable total of squares for a system is expected to be 10-8, and it will converge to a suitable output after around 300 iterations. After the iterations are completed, the output answer is sent to fuzzy to reduce the error. In comparison to other traditional approaches, this ANN with fuzzy will deliver optimal PI parameters and superior outcomes.

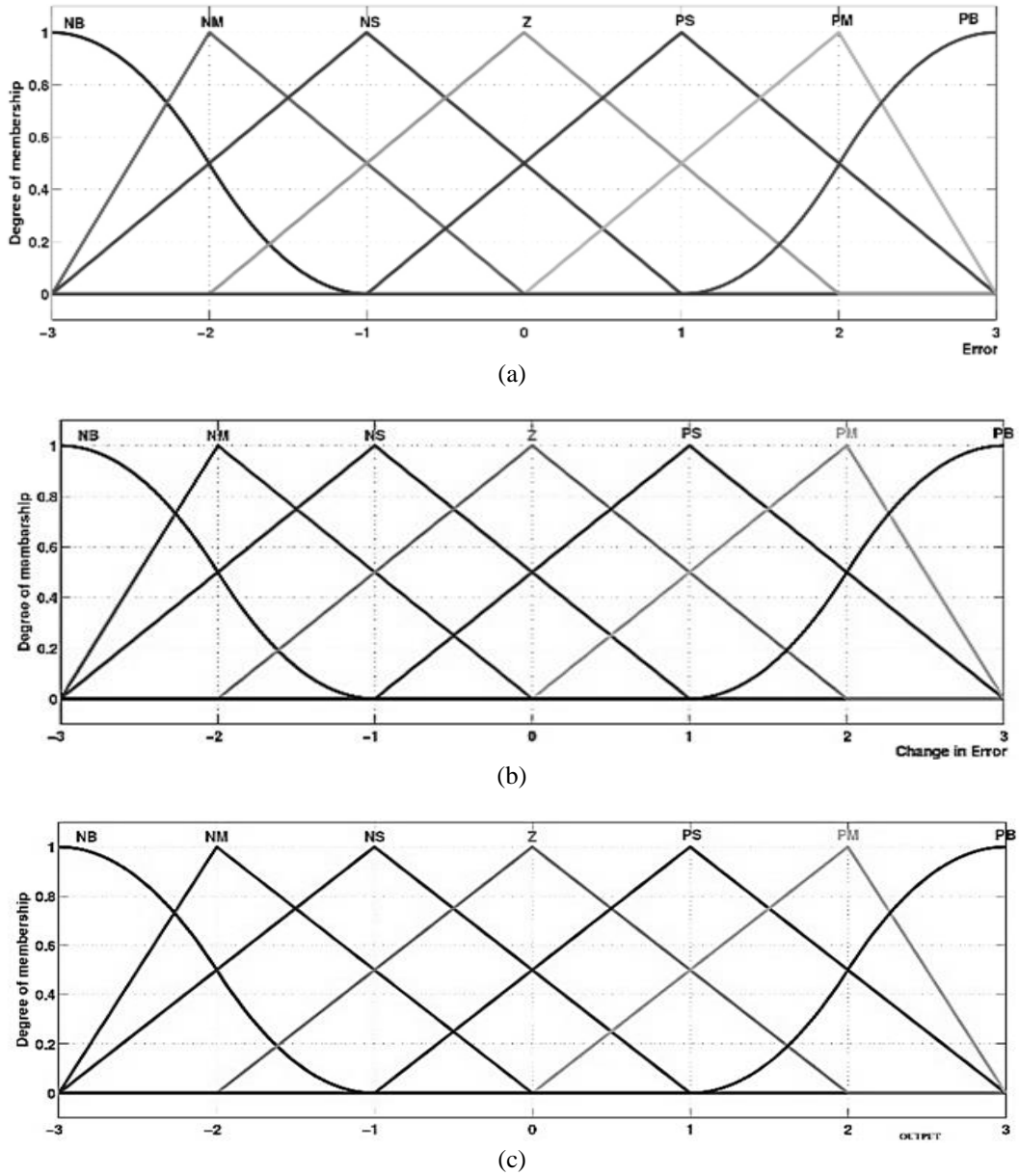

Figure 4. Membership function for (a) error, (b) change in error, and (c) output

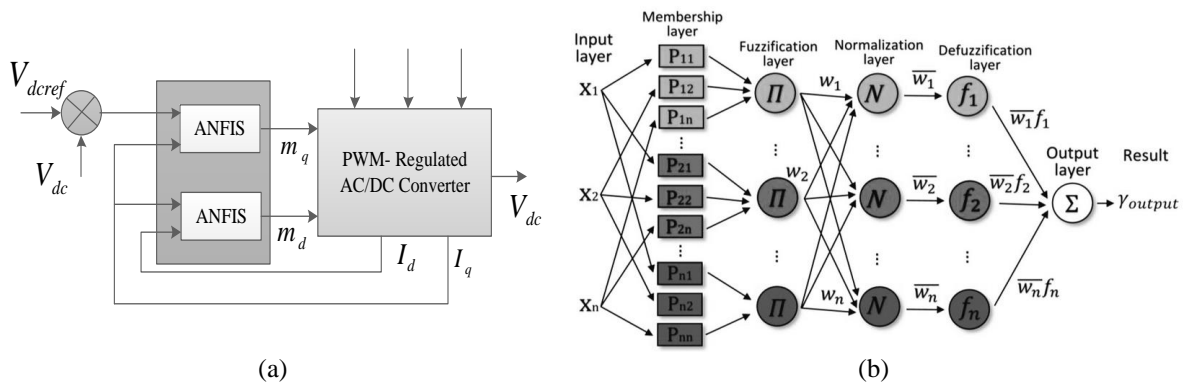

Figure 5. ANFIS based VSI controller design (a) structure of ANFIS based VSC and (b) process layer of ANFIS

#### 4. SIMULATION RESULT

The variation of DC link voltage (step response) is momentarily considered at point  $t=1$  sec as shown in Figure 6. The variation of PV-wind power production based on its availability considered as shown in Figure 7. In PV cell irradiance considered as  $1 \text{ kW/m}^2$  up to  $t=0.3$ , momentarily it is changed to  $0.9 \text{ kW/m}^2$ , the time between  $0.3 \text{ s}$  to  $0.5 \text{ s}$ . At  $t=0.5 \text{ s}$  to  $0.6 \text{ s}$  irradiance is  $0.4 \text{ kW/m}^2$  decreases, and between  $t=0.6 \text{ s}$  to  $t=0.8 \text{ s}$  irradiance considered as  $0.6 \text{ kW/m}^2$ . Similar variation of wind power generation is considered as  $0.82 \text{ m/s}$  to  $t=2 \text{ ms}$ . After wind is increased to  $1.1 \text{ m/s}$  in time between  $t=2 \text{ s}$  to  $4 \text{ sec}$ . Further wind decreased to  $0.7 \text{ m/s}$  time between  $t=4 \text{ s}$  to  $t=6 \text{ s}$  and wind increases to drastically up to  $1.2 \text{ m/s}$  from time between  $t=6 \text{ s}$  to  $t=8 \text{ s}$ .

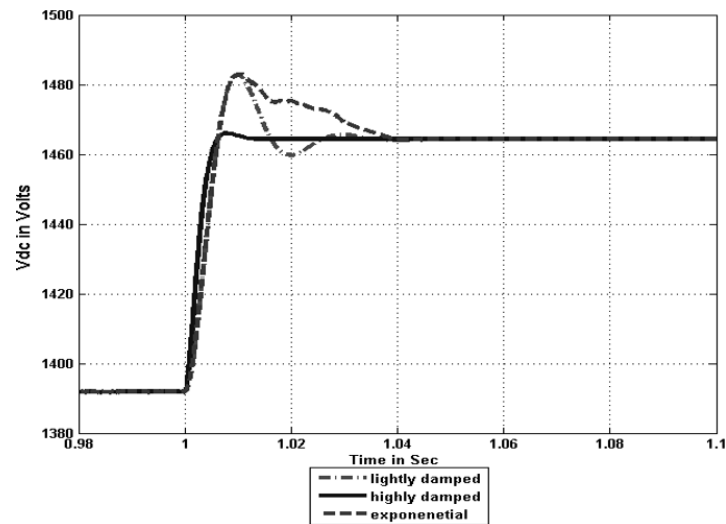

Figure 6. Step variation of DC link voltage

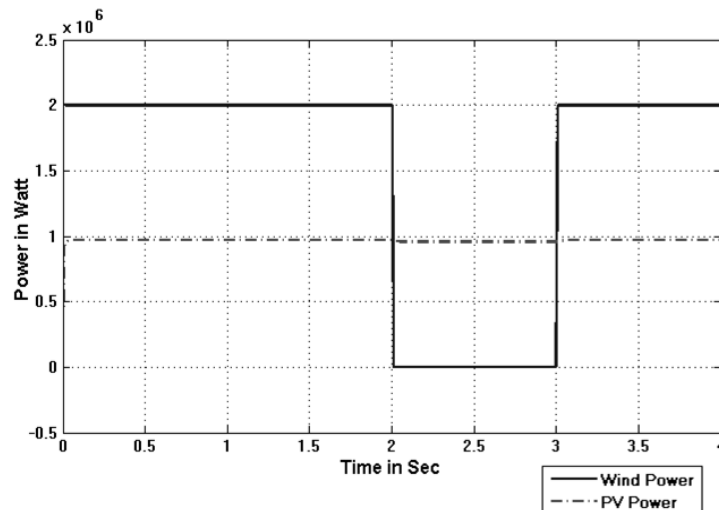

Figure 7. Variation of solar-wind power generation

##### 4.1. ANFIS based VSI controller design

The performance of the smart grid with both PV-wind power generation is shown in Figures 8(a) to 8(g) those are PMSG speed, voltage at DC link capacitor, wind power, solar power, grid current, voltage across CPI, VSR modulation respectively. From the Figures 8(b) and 8(f) it is clear that fixed voltages are produced with even variable PV-wind power generation. Effective power management done between grid-PV-wind (smart grid) with employing ANFIS operated VSC converters.

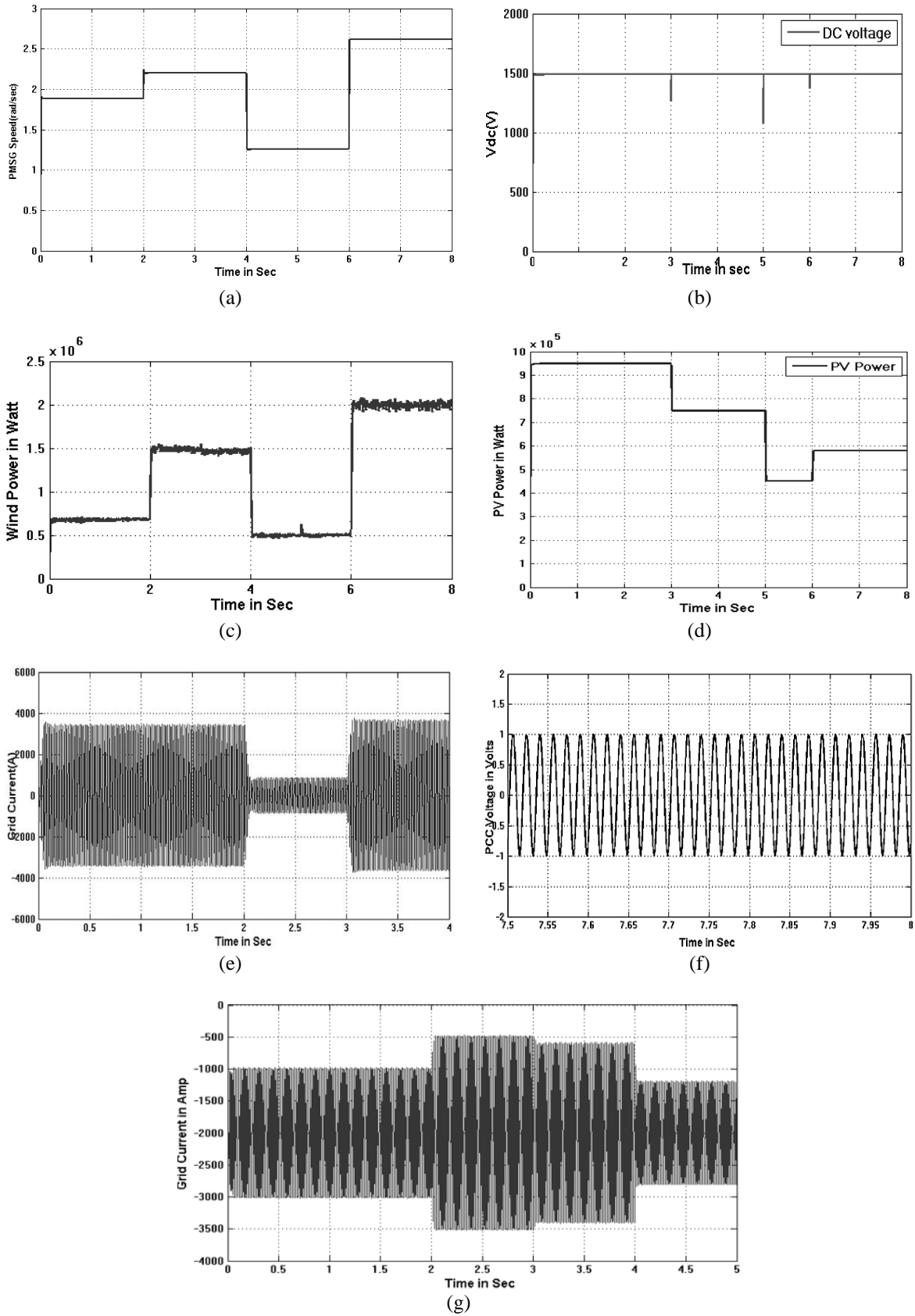

Figure 8. Performance of the smart grid with both PV-wind power generation (a) PMSG speed (rad/sec), (b) DC link voltage, (c) wind power (W), (d) solar power (W), (e) grid current, (f) voltage at CPI, and (g) VSR modulation

#### 4.2. Performance of the system only with wind power generation

The energy management of the smart-grid only with wind is described in this session. In this low or zero irradiance (during night) appearances power establishment done by solar is minimum. In this situation wind energy is only prime responsible to reach the load demand. The output simulation results are illustrated in Figures 9(a) to 9(c). Those are wind speed, wind power and grid current respectively.

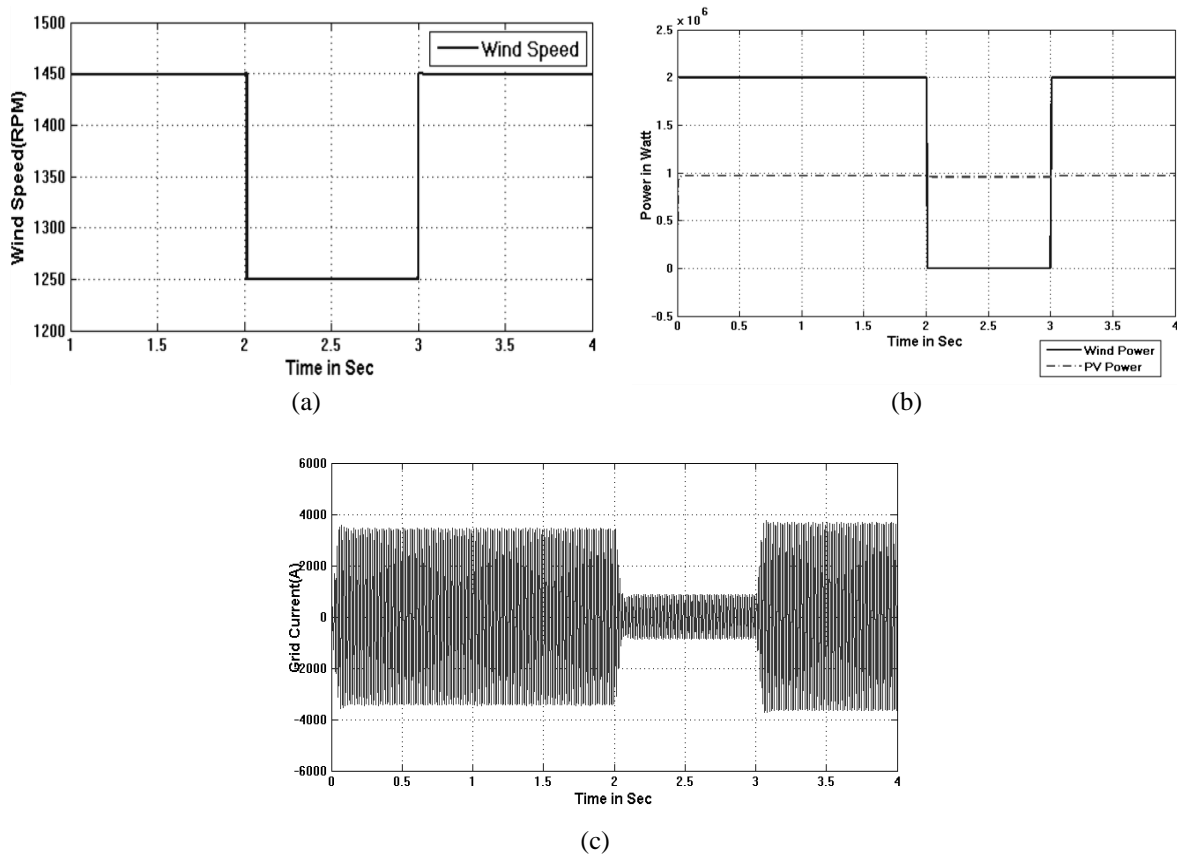

Figure 9. Simulation results of the system only with wind power generation (a) wind speed, (b) wind power, and (c) grid current

#### 4.3. Performance of the system only with solar power generation

The performance of the smart grid with solar power and low wind power generation is considered in this condition. The performance of the output simulation results is mentioned in Figure 10. Figures 10(a) to 10(c) show the PMSG speed, solar power, and grid current.

#### 4.4. Performance of the system with symmetrical fault

A symmetrical L-L-L-G (3ph fault) is created for solar power network (1 pu) and wind power (0.5 pu) at  $t=4$  secs. The obtained performance simulation results are shown in Figures 11(a) to 11(c) those are DC link voltage with protection, grid current, and DC link voltage without protection respectively. From Figure 12 comparison of DC link voltage with protection controller and without controller it clear that with using proposed technique the oscillations occurred in grid current is less. It is mitigated within the first four cycles. Total harmonic distortion (THD) of grid current and grid voltage of conventional controller and proposed controller is shown in Figure 13. Comparison THD for grid current with Figure 13(a) conventional controller and Figure 13(b) proposed controller and shown in Figure 14. Comparison THD for grid voltage with Figure 14(a) conventional controller Figure 14(b) proposed controller respectively.

The results show that the THD values of grid current is 19.72% and grid voltage THD is 44.05% with ANFIS controller. This controller is also able to effectively compensate all the parameter. Hence ANFIS controller is most effective of PI controllers developed. Comparison of THD with PI and ANFIS controllers is shown in Table 2.



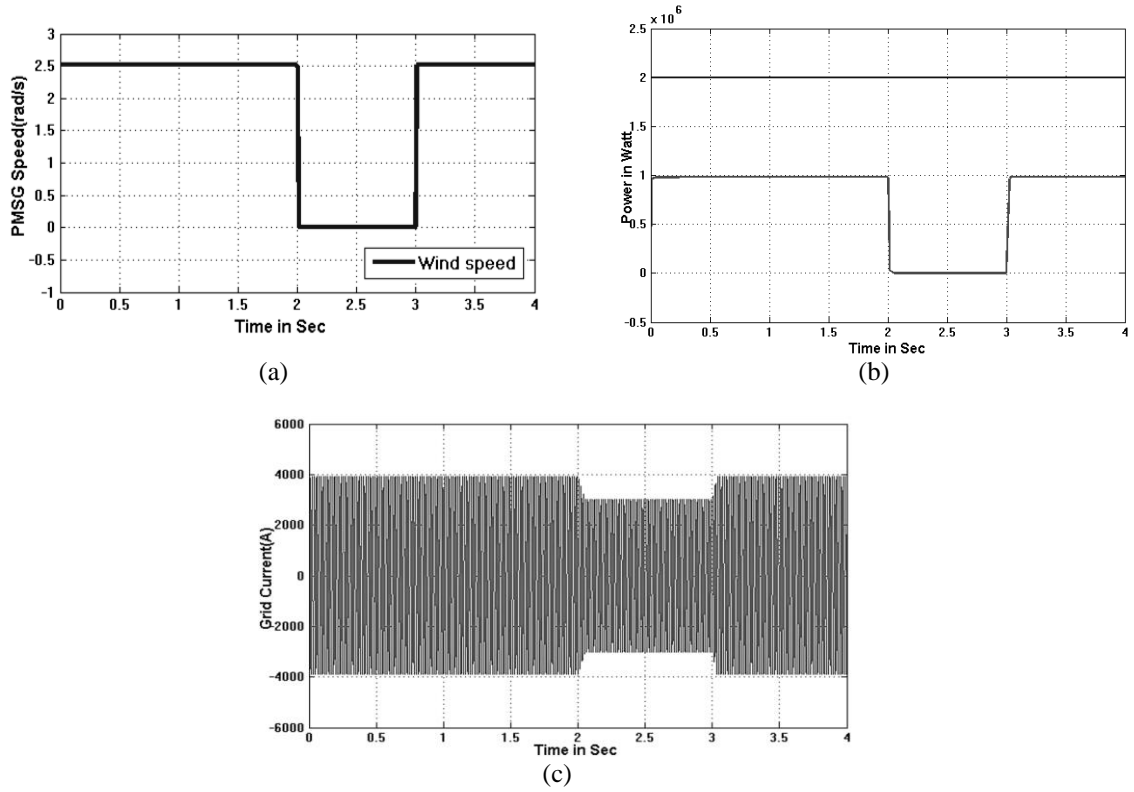

Figure 10. Simulation result of wind speed, solar power and grid current (a) wind speed, (b) solar power, and (c) grid current

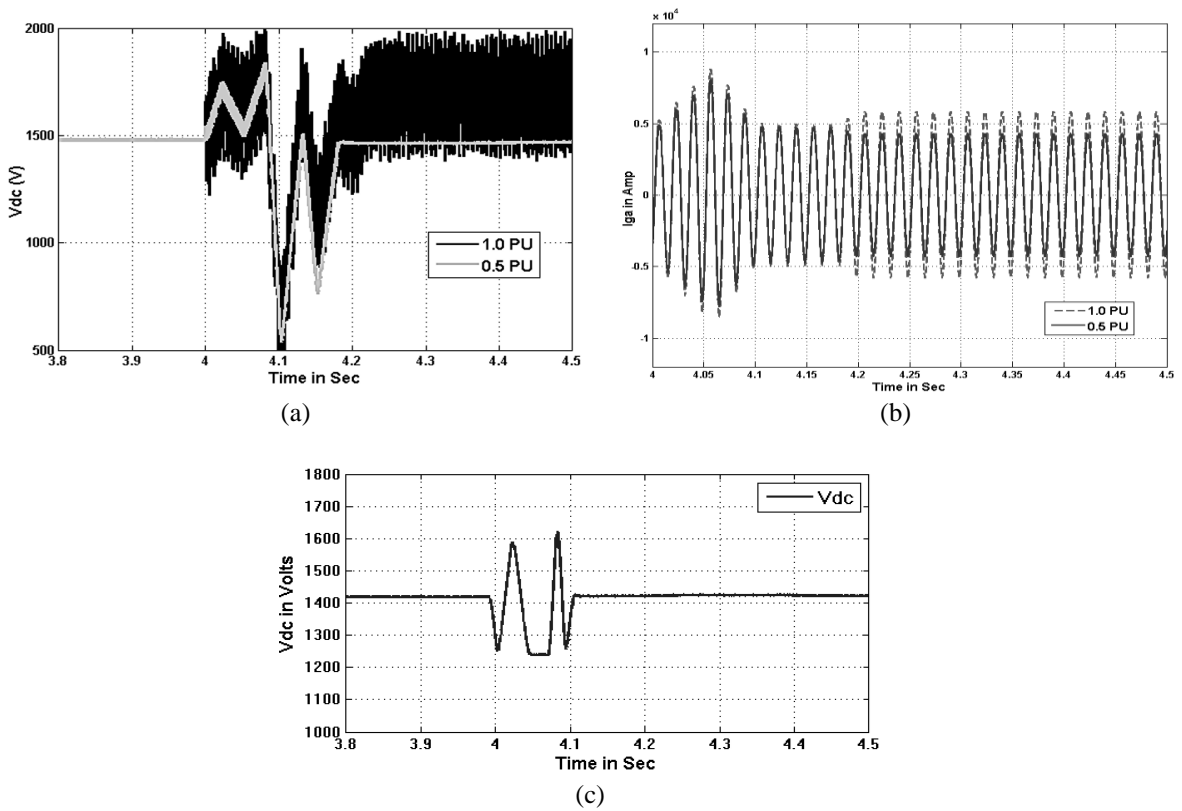

Figure 11. Simulation results of the system with symmetrical fault (a) DC link voltage with fault and ANFIS controller, (b) grid current with protection, and (c) DC link voltage without protection

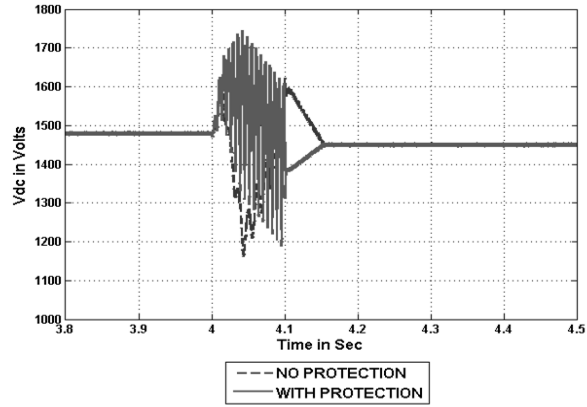
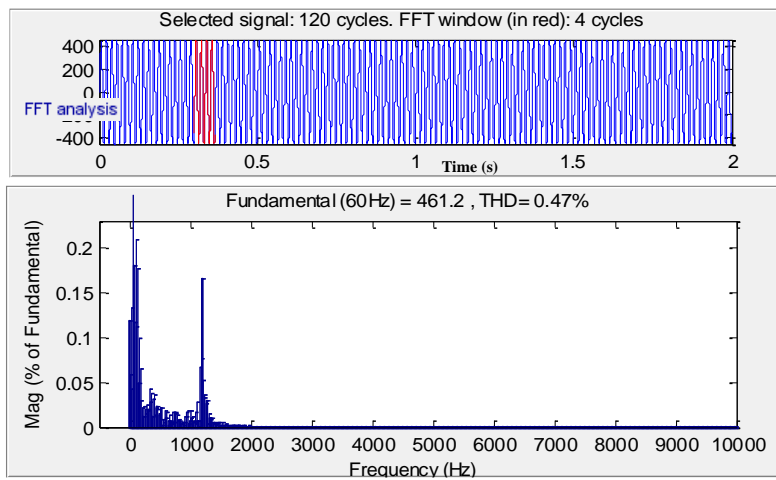
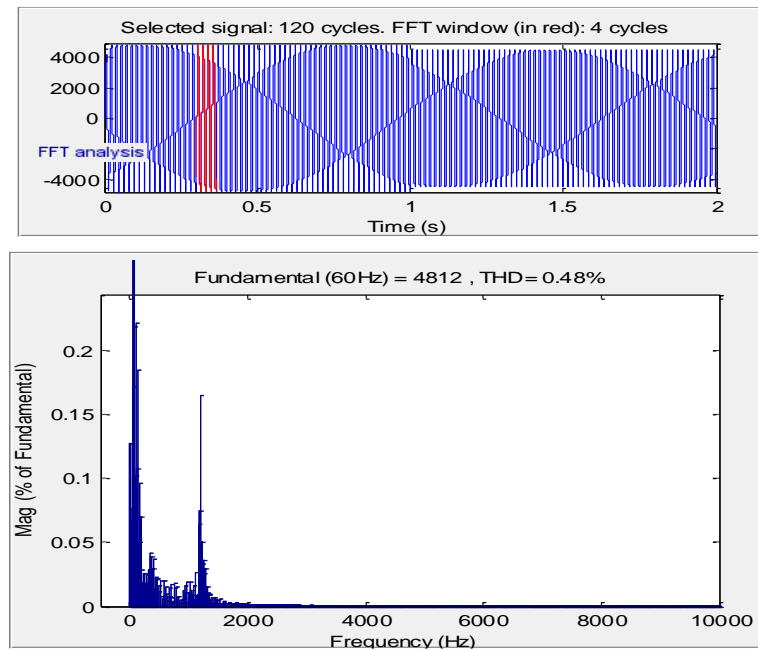

Figure 12. DC link voltage with and without protection



(a)



(b)

Figure 13. Conventional PI controller (a) Grid voltage THD and (b) Grid current THD

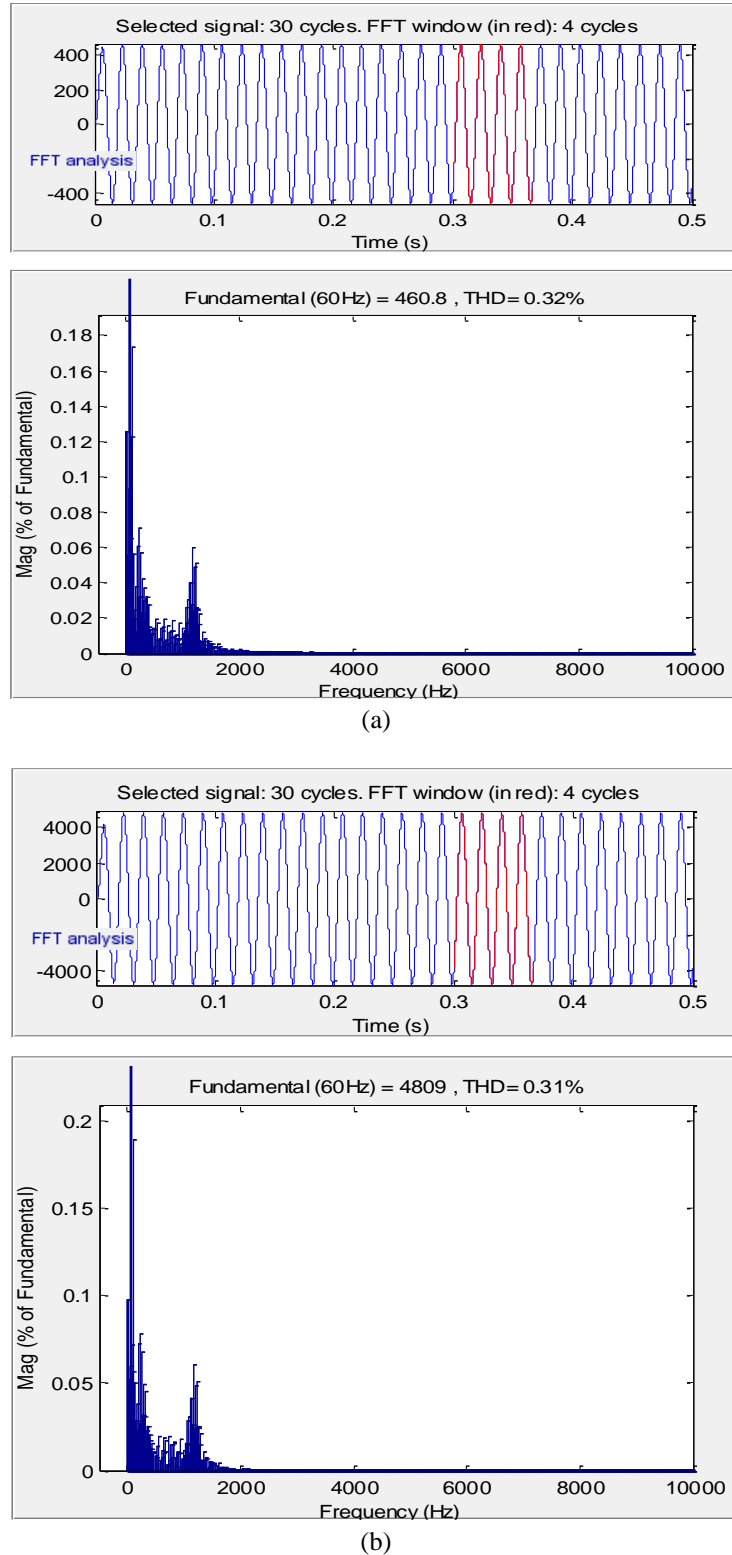

Figure 14. Proposed ANFIS controller (a) Grid voltage THD and (b) Grid current THD

Table 2. Comparison table for THD with PI and ANFIS controller

S. No	Parameters	Conventional Controller (PI)	Proposed Controller (ANFIS)
01	grid current	0.48%	0.31 %
02	grid voltage	0.47%	0.32%

## 5. CONCLUSION

This research investigates an efficient ANFIS control based smart grid to improve power quality. Obtained simulation results for performance system only with solar power and low wind energy, with wind energy and low solar power and both solar-wind powers are presented. From the simulations it is clear that the current's harmonic content is reduced by 0.48% to 0.31% and voltage harmonics is reduced to 0.47% to 0.32% by ANFIS controller in contrast to conventional PI controller. In addition, it is observed that it has improved dynamic performance compared to the conventional control-based techniques like PI controllers, individual loop control techniques. The proposed ANFIS control-based approach reduces network failure tolerance and improves power quality.



## REFERENCES

- [1] S. Salman, X. AI, and Z. WU, "Design of a P-&O algorithm based MPPT charge controller for a stand-alone 200W PV system," *Protection and Control of Modern Power Systems*, vol. 3, no. 1, p. 25, Dec. 2018, doi: 10.1186/s41601-018-0099-8.
- [2] D. Haji and N. Genc, "Fuzzy and P&O based MPPT controllers under different conditions," in *2018 7th International Conference on Renewable Energy Research and Applications (ICRERA)*, Oct. 2018, pp. 649–655, doi: 10.1109/ICRERA.2018.8566943.
- [3] B. Bhandari, S. R. Poudel, K.-T. Lee, and S.-H. Ahn, "Mathematical modeling of hybrid renewable energy system: A review on small hydro-solar-wind power generation," *International Journal of Precision Engineering and Manufacturing-Green Technology*, vol. 1, no. 2, pp. 157–173, Apr. 2014, doi: 10.1007/s40684-014-0021-4.
- [4] M. G. Simoes, B. K. Bose, and R. J. Spiegel, "Fuzzy logic based intelligent control of a variable speed cage machine wind generation system," in *Proceedings of PESC '95-Power Electronics Specialist Conference*, 1995, vol. 1, pp. 389–395, doi: 10.1109/PESC.1995.474840.
- [5] R. Chedid, F. Mrad, and M. Basma, "Intelligent control of a class of wind energy conversion systems," *IEEE Transactions on Energy Conversion*, vol. 14, no. 4, pp. 1597–1604, 1999, doi: 10.1109/60.815111.
- [6] T. Hirose and H. Matsuo, "Standalone hybrid wind-solar power generation system applying dump power control without dump load," *IEEE Transactions on Industrial Electronics*, vol. 59, no. 2, pp. 988–997, Feb. 2012, doi: 10.1109/TIE.2011.2159692.
- [7] K. Kant, C. Jain, and B. Singh, "A hybrid diesel-wind -PV-based energy generation system with brushless generators," *IEEE Transactions on Industrial Informatics*, vol. 13, no. 4, pp. 1714–1722, Aug. 2017, doi: 10.1109/TII.2017.2677462.
- [8] K. Sharma and D. K. Palwalia, "Robust controller design for DC-DC converters using fuzzy logic," in *2017 4th International Conference on Signal Processing, Computing and Control (ISPCC)*, Sep. 2017, pp. 477–481, doi: 10.1109/ISPCC.2017.8269726.
- [9] P. K. Ray, S. R. Das, and A. Mohanty, "Fuzzy-controller-designed-PV-based custom power device for power quality enhancement," *IEEE Transactions on Energy Conversion*, vol. 34, no. 1, pp. 405–414, Mar. 2019, doi: 10.1109/TEC.2018.2880593.
- [10] M. Bollen, J. Zhong, F. Zavoda, J. Meyer, A. McEachern, and F. Córcoles López, "Power quality aspects of smart grids," *Renewable Energy and Power Quality Journal*, vol. 1, no. 08, pp. 1061–1066, Apr. 2010, doi: 10.24084/repqj08.583.
- [11] S. Gheorghie, G. Gheorghie, N. Golovanov, and C. Stanescu, "Results of power quality monitoring in Romanian transmission and distribution system operators," in *2016 International Conference on Applied and Theoretical Electricity (ICATE)*, Oct. 2016, pp. 1–6, doi: 10.1109/ICATE.2016.7754628.
- [12] M. E. Ralph, "Control of the variable speed generator on the Sandia 34-m vertical axis wind turbine," *presented at the Windpower '89 Conf.* San Francisco, CA, 1989.
- [13] T. A. Lipo, "Variable speed generator technology options for wind turbine generators," *NASA Workshop, Cleveland*, 1984.
- [14] C. Nayar and J. H. Bundell, "Output power controller for a wind-driven induction generator," *IEEE Transactions on Aerospace and Electronic Systems*, vol. AES-23, no. 3, pp. 388–401, May 1987, doi: 10.1109/TAES.1987.310837.
- [15] P. J. Werbos, "From ADP to the brain: Foundations, roadmap, challenges and research priorities," in *Proceedings of the International Joint Conference on Neural Networks*, Jul. 2014, pp. 107–111, doi: 10.1109/IJCNN.2014.6889359.
- [16] P. G. Casielles, J. G. Alexandre, J. Sanz, and J. Pascual, "Design, installation and performance analysis of a control system for a wind turbine driven self-excited induction generator," in *Proceedings ICEM '90*, 1990, pp. 988–993.
- [17] D. A. Torrey, "Variable-reluctance generators in wind-energy systems," in *Proceedings of IEEE Power Electronics Specialist Conference-PESC '93*, 1993, pp. 561–567, doi: 10.1109/PESC.1993.471982.
- [18] C. Brune, R. Spe, and A. K. Wallace, "Experimental evaluation of a variable-speed, doubly-fed wind-power generation system," in *Conference Record of the 1993 IEEE Industry Applications Conference Twenty-Eighth IAS Annual Meeting*, 1994, pp. 480–487, doi: 10.1109/IAS.1993.298967.
- [19] D. M. F. G. Roger, "IEEE recommended practice and requirements for harmonic control in electric power systems," *IEEE Std 519-1992 (Revision of IEEE Std 519-1992)*, pp. 1–20, 2014, doi: 10.1109/IEEESTD.2014.6826459.
- [20] G. C. D. Sousa, B. K. Bose, and J. G. Cleland, "Fuzzy logic based on-line efficiency optimization control of an indirect vector-controlled induction motor drive," *IEEE Transactions on Industrial Electronics*, vol. 42, no. 2, pp. 192–198, Apr. 1995, doi: 10.1109/41.370386.
- [21] G. C. D. Sousa and B. K. Bose, "A fuzzy set theory based control of a phase-controlled converter DC machine drive," *IEEE Transactions on Industry Applications*, vol. 30, no. 1, pp. 34–44, 1994, doi: 10.1109/28.273619.
- [22] D. Krishna, M. Sasikala, and V. Ganesh, "Adaptive FLC-based UPQC in distribution power systems for power quality problems," *International Journal of Ambient Energy*, pp. 1–11, Feb. 2020, doi: 10.1080/01430750.2020.1722232.
- [23] P. E. Bett and H. E. Thornton, "The climatological relationships between wind and solar energy supply in Britain," *Renewable Energy*, vol. 87, pp. 96–110, Mar. 2016, doi: 10.1016/j.renene.2015.10.006.
- [24] D. Krishna, M. Sasikala, and V. Ganesh, "Mathematical modeling and simulation of UPQC in distributed power systems," in *2017 IEEE International Conference on Electrical, Instrumentation and Communication Engineering (ICEICE)*, Apr. 2017, pp. 1–5, doi: 10.1109/ICEICE.2017.8191886.
- [25] D. Krishna, M. Sasikala, and V. Ganesh, "Fuzzy based upqc in a distributed power system for enhancement of power quality," *International Journal of Pure and Applied Mathematics*, vol. 118, no. 14, pp. 689–698, 2018.
- [26] S. Ravi and K. Dhee, "Improvement of dynamic performance of induction motor drives by using flc based MPFC," *International Journal of Innovative Technology and Exploring Engineering (IJITEE)*, vol. 8, no. 2S, pp. 240–245, 2018.



- [27] D. C. Sekhar, P. V. V. R. Rao, and V. Ganesh, "Weight feedback adaptive multi objective cooperative scheduling in smart grid application," *International Journal of Recent Technology and Engineering (IJRTE)*, vol. 8, no. 2, pp. 607–611, 2019.
- [28] C. R. Reddy and K. H. Reddy, "Islanding detection techniques for grid integrated DG: a review," *International Journal of Renewable Energy Research (IJRER)*, vol. 9, no. 2, pp. 960–977, 2019.
- [29] R. Thumu, K. Harinadha Reddy, and C. Rami Reddy, "Unified power flow controller in grid-connected hybrid renewable energy system for power flow control using an elitist control strategy," *Transactions of the Institute of Measurement and Control*, vol. 43, no. 1, pp. 228–247, Jan. 2021, doi: 10.1177/0142331220957890.
- [30] B. S. Goud, B. L. Rao, and C. R. Reddy, "An intelligent technique for optimal power quality reinforcement in a grid-connected HRES system: EVORFA technique," *International Journal of Numerical Modelling: Electronic Networks, Devices and Fields*, vol. 34, no. 2, Mar. 2021, doi: 10.1002/jnm.2833.

## BIOGRAPHIES OF AUTHORS





**Dharamalla Chandra Sekhar**    received the B. Tech Degree in Electrical and Electronics Engineering from Jawaharlal Nehru Technological University Hyderabad, India and the M. Tech in Power Electronics from Jawaharlal Nehru Technological University Hyderabad, India. Currently, He is Research Scholar in Jawaharlal Nehru Technological University Anantapur, India and also, He is an Assistant Professor at the Department of Electrical and Electronics Engineering, Malla Reddy Engineering College (Autonomous), Secunderabad, Telangana, India. His research interests include renewable energy, power quality, power electronics and drives, smart grid, load flow control, particle swarm optimization, power distribution protection, neural networks, fuzzy systems and artificial intelligence applied to power system and power electronics. He can be contacted at e-mail: [daram.sekhar@gmail.com](mailto:daram.sekhar@gmail.com).



**Pokanati Veera Venkata Rama Rao**    received the B. Tech Degree in Electrical and Electronics Engineering from Jawaharlal Nehru Technological University Hyderabad, India. M.Tech Degree from Jawaharlal Nehru Technological University Hyderabad, India and Ph.D. Degree in Jawaharlal Nehru Technological University Hyderabad, India. Currently, he is Professor in the Department of Electrical and Electronics Engineering at Maturi Venkata Subba Rao Engineering College (Autonomous), Hyderabad, India. He has authored or coauthored more than 40 refereed journals and 60 conference papers. He received five project grants from external funded organizations. His research interests include the applications of artificial intelligence in electrical power systems, evolutionary and heuristic optimization techniques to power system planning, operation, and control, micro grid, smart grid and electrical vehicles. He can be contacted at e-mail: [pvmadhuram@gmail.com](mailto:pvmadhuram@gmail.com).



**Rachamadugu Kiranmayi**    received the B.Tech. Degree in Electrical and Electronics Engineering from Jawaharlal Nehru Technological University Hyderabad, India. M. Tech. Degree in Electrical Power Systems from Jawaharlal Nehru Technological University Hyderabad, India and Ph.D. Degree in Electrical Engineering from Jawaharlal Nehru Technological University Anantapur, Andhra Pradesh, India. She is currently Professor in the Department of Electrical and Electronics Engineering and the Director, Foreign Affairs and Alumni Matters at Jawaharlal Nehru Technological University Anantapur, Andhra Pradesh, India. She has authored or coauthored more than 50 refereed journals and conference papers. Her research interests include renewable energy sources, micro grid, load flow studies, smart grid, and applications of artificial intelligence. She can be contacted at e-mail: [kiranmayi0109@gmail.com](mailto:kiranmayi0109@gmail.com).