

28 GHz balanced pHEMT VCO with low phase noise and high output power performance for 5G mm-wave systems

Abdelhafid Es-saqy¹, Maryam Abata², Mahmoud Mehdi³, Said Mazer⁴, Mohammed Fattah⁵,
Moulhime El Bekkali⁶, Catherine Algani⁷

^{1,2,4,6}Artificial Intelligence, Data Sciences and Emerging Systems Laboratory, Sidi Mohamed Ben Abdellah University, Morocco

³Microwaves Laboratory, Lebanese University, Lebanon

⁵EST, My Ismail University, Morocco

⁷ESYCOM (EA2552), Conservatoire National Des Arts Et Métiers, France

Article Info

Article history:

Received Dec 16, 2019

Revised Mar 12, 2020

Accepted Mar 30, 2020

Keywords:

5G

Colpitts VCO

Low phase noise

mm-wave band

pHEMT transistor

ABSTRACT

This paper presents the study and design of a balanced voltage controlled oscillator VCO for 5G wireless communication systems. This circuit is designed in monolithic microwave integrated circuit (MMIC) technology using PH15 process from UMS foundry. The VCO ensures an adequate tuning range by a single-ended pHEMT varactors configuration. The simulation results show that this circuit delivers a sinusoidal signal of output power around 9 dBm with a second harmonic rejection between 25.87 and 33.83 dB, the oscillation frequency varies between 26.46 and 28.90 GHz, the phase noise is -113.155 and -133.167 dBc/Hz respectively at 1 MHz and 10 MHz offset and the Figure of Merit is -181.06 dBc/Hz. The power consumed by the VCO is 122 mW. The oscillator layout with bias and RF output pads occupies an area of 0.515 mm².

*Copyright © 2020 Institute of Advanced Engineering and Science.
All rights reserved.*

Corresponding Author:

Abdelhafid Es-saqy,

Artificial Intelligence, Data Sciences and Emerging Systems Laboratory,

Sidi Mohamed Ben Abdellah University,

Dar Said, Tissa, Taounate, Morocco.

Email: abdelhafid.essaqy@usmba.ac.ma

1. INTRODUCTION

Reflected by the fast pace of technology innovation, wireless communication is the fastest growing technology in the world. Currently, necessitates more than ten billion of machine-to-machine communications and Internet of Things to fulfil the requirements for autonomous vehicles, intelligent home, smart grid, smart city [1] and E-health services [2, 3]. Therefore, the enormous need for the new broadband frequencies [4]. Fortunately, large quantities of relatively inactive spectrum exist in the millimeter wave band [5]. The most recent researches focused on the 28 GHz band, the 38 GHz band, the 60 GHz band and the E-band [6].

The object of a communication system is to establish seamless communications with reasonable cost and reduced power consumption, the upcoming mobile communication system generation 5G is aiming to fulfil these important requirements [4]. Any RF transmission / reception shown in Figure 1 system has one or more local oscillators. An oscillator is an autonomous system generating a fixed or variable frequency signal [7]. In RF transceivers, oscillator signals are used as a frequency reference to convert the RF signal to an intermediate frequency. In all RF applications, it is necessary to have sinusoidal references of a high spectral purity, this is, moreover, one of the most important characteristics of an oscillator.

In the literature, many VCOs have a relatively good FoM, however, observing the covered frequency range, we notice that it is very low: 5.45% and 6.91% of the central frequency for the two VCOs proposed in [8], 5.44% and 3.3% respectively for the VCOs proposed in [9, 10]. On the other side, structures with wide frequency ranges but low phase noise levels, less than -102 dBc/Hz, which do not fulfill the 5G

requirements [11-13]. In addition to all these considerations, there is also the problem of the large space occupied by these circuits, of which it is in the order of 1.5 mm^2 [9] or much more [12-14].

In this paper, a large tuning range MMIC VCO with good phase noise level is proved. The circuit is designed based on a balanced Colpitts architecture. It has a tuning range that exceeds 8.8 % of central frequency and a phase noise around -113 dBc/Hz at 1 MHz offset. This circuit is designed based on the pseudo-morphic High Electron Mobility Transistor pHEMT of PH15 process from UMS foundry, dedicated to RF applications, with a cut off frequency of $f_T = 110\text{GHz}$ and a $0.15 \mu\text{m}$ gate length [15]. The remainder of this paper is structured as follows: Section 2 presents the 5G mm-Wave VCO circuit design, Section 3 reports VCO layout and discusses the simulation results. A conclusion is given in section 4.

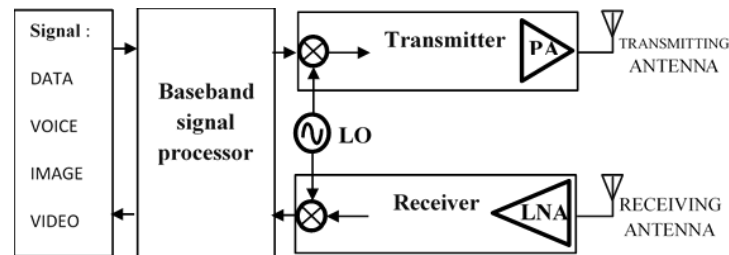

Figure 1. Simplified diagram of transmission/reception system

2. 5G MM-WAVE VCO DESIGN

After choosing the semiconductor technology and transistor type, it is time to choose the most suitable VCO topology for the 5G mm-wave band application. The simplified schematic (i.e., without transmission lines) of the studied VCO is shown in Figure 2, it is a modified version of the Colpitts structure, which combines a good phase-noise level with improved starting conditions. The active part of the VCO is composed of the two GaAs pHEMT transistors, T1 and T2, of gate length of $4 \times 0.15 \mu\text{m}$ and width of $20 \mu\text{m}$, and their bias elements, we have chosen transistors with a high number of fingers to increase the output power [9]. The performance of the active device, at the millimeter frequency, depends strongly on biasing conditions [16], the biasing of these transistors is provided by the two voltage sources V_{ds} and V_{gs} of 2 V and 0.2 V respectively. While the inductance L_r as well as the two varactors T3 and T4 constitute the resonator. These varactors are based on the pHEMT transistor whose source is connected to the drain, the capacitance value of these varactors is controlled by the voltage applied to the gate V_{tune} . Finally, a capacitor C has been added at the output of the oscillator whose role is to filter the DC component which comes from the bias sources. We announce that this circuit is based on the PH15 process elements of the UMS foundry, whose behavior is very close to reality, thus they present parasites and imperfections.

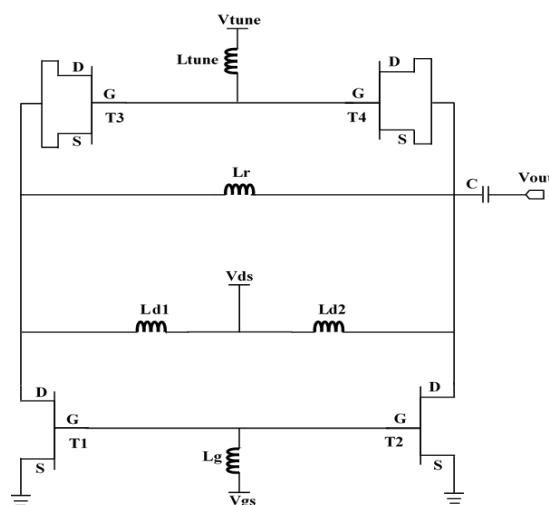

Figure 2. pHEMT balanced VCO circuit

3. SIMULATIONS AND DISCUSSIONS

At millimeter frequencies, parasitic capacitances, transmission line inductances and other connections can catastrophically change reactances and can have a significant impact on the performance of the final circuit, which is why several optimization and retro-simulation steps are performed before the final layout as shown in Figure 3. Particular attention is paid to the Layout symmetry, to avoid the introduction of asymmetry in the oscillation waveforms and thus introduce additional phase noise [17]. According to the circuit layout as shown in Figure 3, we observe three bias pads, one pad for the tuning voltage V_{tune} and one RF pad for the output signal. The circuit is implanted on the GaAs substrate, it is a multilayer technology. The total number of layers used in the PH15 process is 16 layers [18]. The length of this Layout is 0.761 mm while the width is 0.677 mm, thus a total surface area of 0.515 mm^2 , since this surface includes the VCO with RF pad, the tuning voltage pad and the three bias pads as well as the capacity that acts as a low pass filter. We can note that it is a very compact Layout and takes up a small area compared with the architecture published in the literature.

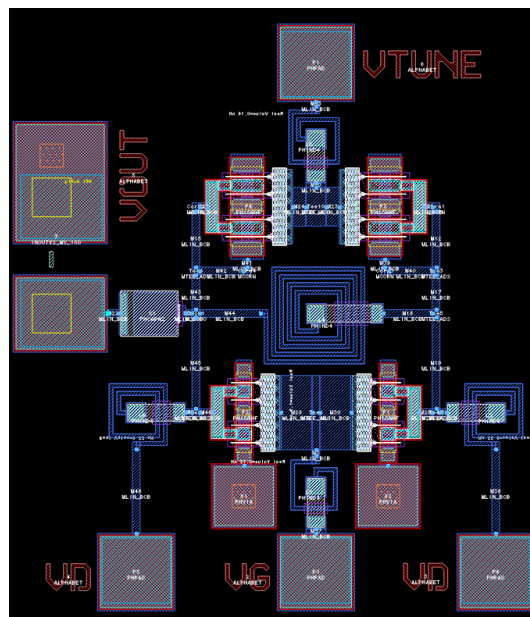

Figure 3. Layout of 5G mm-wave voltage controlled oscillator

After checking the start-up conditions of our oscillator using the "OscTest" tool provided by Agilent's ADS software. A transient simulation is executed to verify the stability of the output signal. Figure 4 shows that the start-up conditions of the oscillations are very good, the oscillations start effectively, and they are perfectly stable.

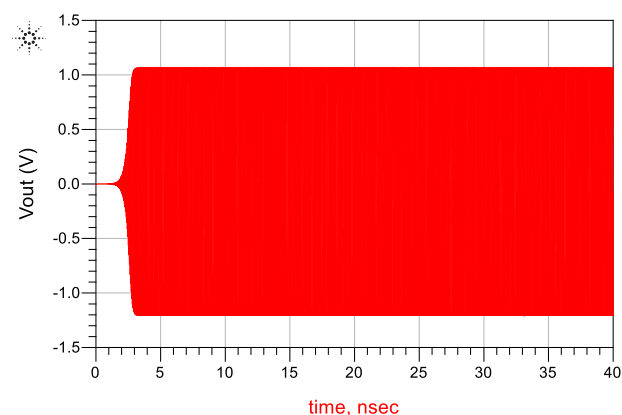

Figure 4. Temporal variation of the output signal V_{out} for $V_{tune}= 2 \text{ V}$

The harmonic simulation shows that the minimum value of the output power is 5.02 dBm, while the maximum value is 9.75 dBm. The second harmonic rejection varies between 25.87 and 33.83 dB for the oscillation frequencies 28.12 and 26.48 GHz respectively, while the third harmonic rejection varies between 44.75 and 55.93 dB for the oscillation frequencies 28.41 and 26.48 GHz respectively shown in Figure 5. Therefore, we notice that our circuit has a good level of rejection of unwanted harmonics.

In Figure 6 we have plotted the variation of the oscillation frequency as a function of the tuning voltage V_{tune} . For a variation of the tuning voltage V_{tune} from -2 to 2.5 V, the oscillation frequency varies from 28.90 to 26.46 GHz. Therefore, a tuning range of 2.44 GHz and a gain of $K_{VCO}=542$ MHz/V are achieved. Figure 7 shows the temporel variation of the output signal V_{out} for $V_{tune}=2.5$ V, therefore it is a perfectly sinusoidal signal.

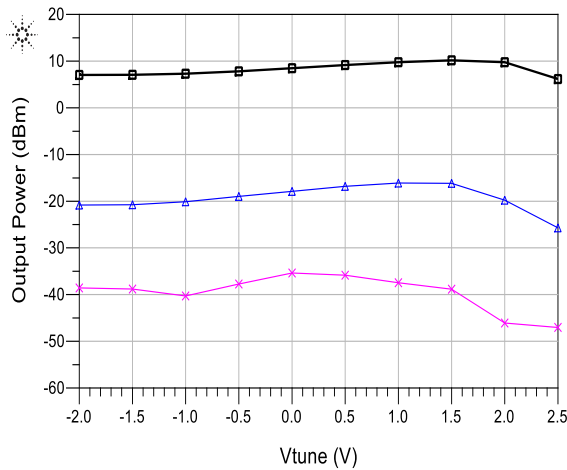

Figure 5. Output power of the first harmonic (-□-), second harmonic (-Δ-) and third harmonic (-x-) versus tuning voltage V_{tune}

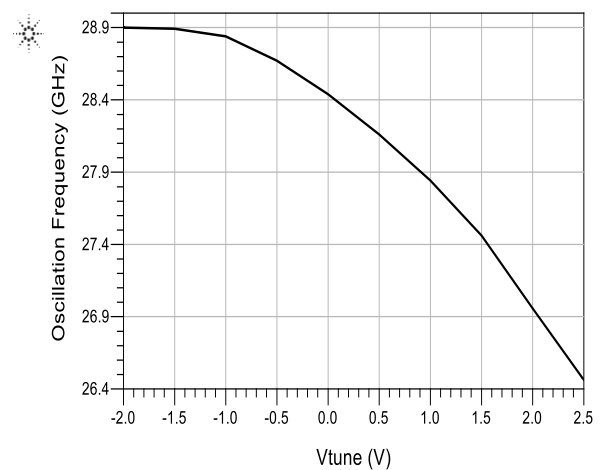

Figure 6. Variation of the oscillation frequency versus tuning voltage V_{tune}

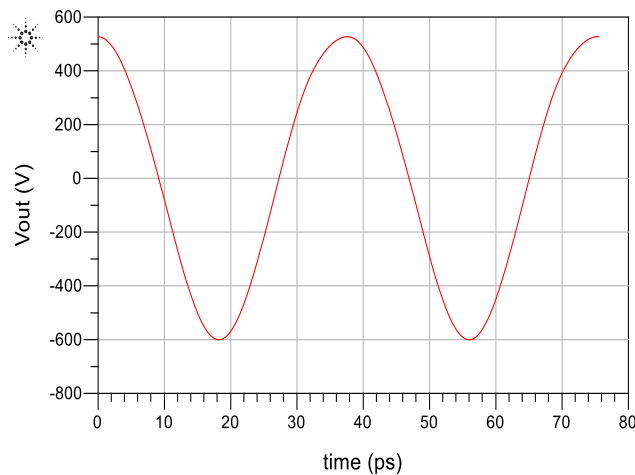

Figure 7. Temporal variation of the output signal for $V_{tune}=2.5$ V

The VCO performance determines the characteristics of the entire transmission system, therefore, to have a signal of high spectral purity, the VCO phase noise must be as minimal as possible [19, 20]. Figure 8 shows the single sideband phase noise and the absolute noise voltage spectrum for $V_{tune}=1.5$ V, thus the phase noise is -93.04 and -113.155 dBc/Hz at the offset frequency of 100 KHz and 1 MHz respectively. On the other hand, the simulation shows that the power consumed by this VCO topology is 122 mW.

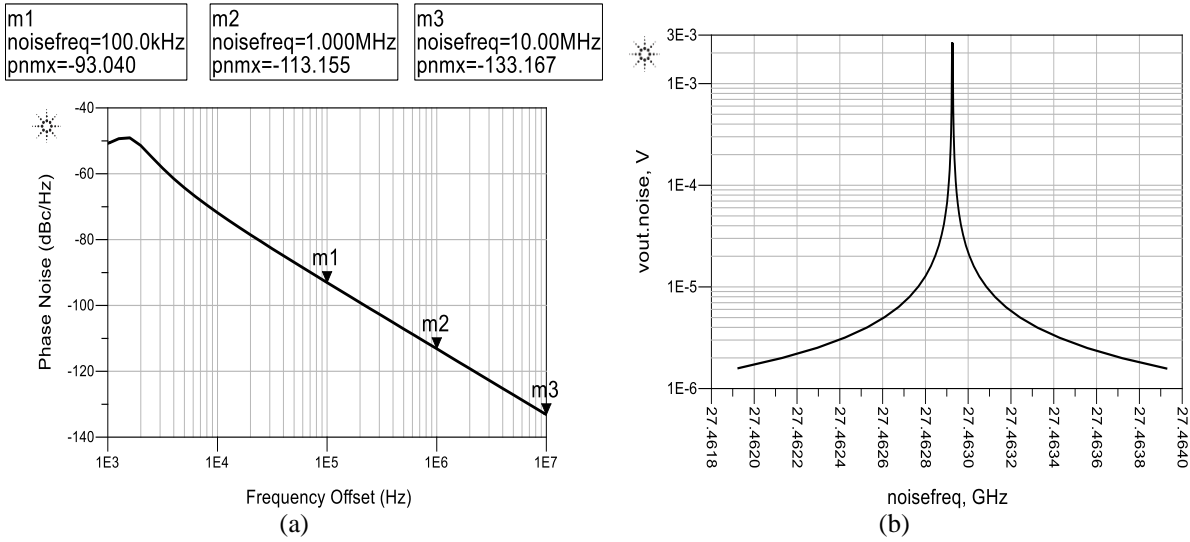

Figure 8. Single sideband phase noise, (a) absolute noise voltage spectrum, (b) for tuning voltage $V_{tune} = 1.5$ V

Depending on the desired application, a voltage-controlled oscillator could even have completely different specifications, making it difficult to compare VCOs with each other. A FoM merit factor is then defined to represent the overall performance of an oscillator [14, 21-23]:

$$FoM = L(f_0, \Delta f) + 10 \log(P_{DC}) - 20 \log\left(\frac{f_0}{\Delta f}\right) \tag{1}$$

where $L(f_0, \Delta f)$ is the phase noise at Δf frequency offset, f_0 is the oscillation frequency and P_{DC} is the power consumption of VCO in mW.

To compare the performance of our voltage controlled oscillator circuit with other structures published in the literature; Table 1 summarizes the performance of different oscillators, designed with different technologies, operating in the same frequency band and dedicated for the same applications. From Table 1 we can see that the architecture proposed in this paper has very good performance; the best level of phase noise, an excellent output power, a low power consumption and therefore a good figure of merit.

Table 1. Performance comparison of different VCOs

Ref.	Central frequency (GHz)	Tuning range (GHz)	Output power (dBm)	Phase noise (dBc/Hz) at 1MHz	FoM (dBc/Hz)	Chip area (mm ²)	Structure	Technologie
[8]	25.6	1.77	3	-101.9	-176.7	0.034	On-chip inductor	0.13 μ m CMOS
[8]	40.7	2.22	-6.6	-94.8	-172.1	0.018	On-chip inductor	0.13 μ m CMOS
[12]	29.4	14.8	4.5	-100.7	-169.11	3.75	4 Colpitts VCO	0.13 μ m SiGeBiCMOS
[13]	28.3	3.8	11.8	-102	-	0.5	Negative resistance	0.15 μ m pHEMT
This work	27.7	2.44	9.75	-113.155	-181.06	0.515	Colpitts	0.15 μ m GaAs pHEMT

Finally, in order to characterize the performance of a millimeter frequency circuit, the effect of technological dispersion must be evaluated. The Monte Carlo analysis proposed by the ADS software, allows to cause small random variations in the values of the different circuit parameters, and to predict the impact of these variations on the performance of our circuit [24, 25]. We performed a Monte Carlo analysis at 50 iterations. Figure 9 shows the results of technological dispersion. We can deduce that for all iterations, the fundamental harmonic power and the second harmonic power are subject to limited and acceptable variations over the entire tuning range.

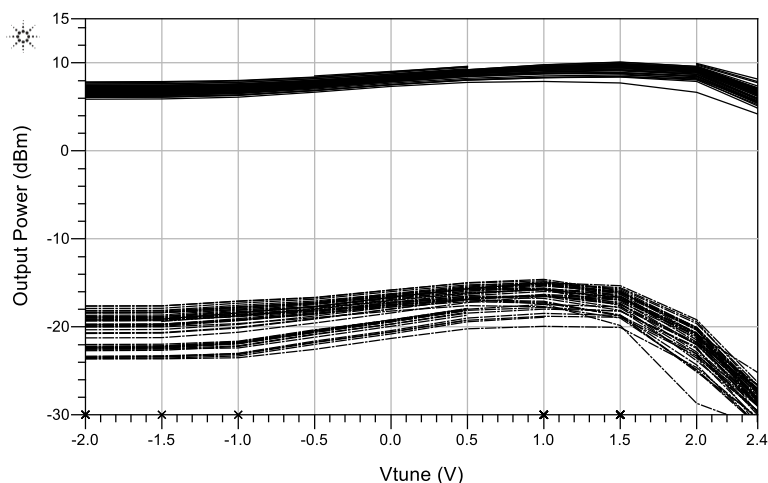

Figure 9. Monte Carlo analysis for the output power of the first harmonic (solid line) and the second harmonic (dash-dotted line)

4. CONCLUSION

In this paper we have presented and designed a pHEMT balanced VCO in MMIC technology for 5G mm-wave band systems. The simulation results showed a tuning range of 2.44 GHz (which represents 8.82% of the central frequency), an output power of 9 dBm, a phase noise of -113.155 dBc/Hz at 1 MHz offset frequency and a figure of merit of -181.06 dBc/Hz. The Layout area is 0.515 mm².

REFERENCES

- [1] A. M. Al-Smadi, *et al.*, "Emergent situations for smart cities: A survey," *International Journal of Electrical and Computer Engineering (IJECE)*, vol. 9, no. 6, pp. 4777-4787, 2019.
- [2] R. Mitra and R. Ganiga, "A novel approach to sensor implementation for healthcare systems using internet of things," *International Journal of Electrical and Computer Engineering (IJECE)*, vol. 9, no. 6, pp. 5031-5045, 2019.
- [3] Boumaiz, M. EL Ghazi, S. Mazer, M. EL Bekkali, A. Bouayad, M. Fattah, "Performance analysis of DQPSK and DBPSK modulation schemes for a scheduled access phase based Wireless Body Area Network," *9th International Symposium on Signal, Image, Video and Communications*, pp. 163-167, 2018.
- [4] S. C. Bera, "Microwave Active Devices and Circuits for Communication," *Springer Lecture Notes in Electrical Engineering*, vol. 533, 2019.
- [5] J. G. Andrews, S. Buzzi, W. Choi, S. Hanly, A. Lozano, A. C. K. Soong, J. C. Zhang, "What Will 5G Be?," *IEEE Journal on Selected Areas in Communications*, vol. 32, pp. 1065-1082, 2014.
- [6] Y. Niu, Y. Li D. Jin, L. Su, A. V. Vasilakos, "A survey of millimeter wave communications (mmWave) for 5G: opportunities and challenges," *Springer Wireless Networks*, vol. 21, pp. 2657-2676, 2015.
- [7] K.A. Humood, O.A. Imran, and A.M. Taha, "Design and simulation of high frequency colpitts oscillator based on BJT amplifier," *International Journal of Electrical and Computer Engineering (IJECE)*, vol. 10, no. 1, pp. 160-170, 2020.
- [8] Y. Huo, X. Dong, L. Li, M. Xie and W. Xu, "26/40 GHz CMOS VCOs Design of Radio Front-end for 5G Mobile Devices," *IEEE International Conference on Ubiquitous Wireless Broadband*, 2016.
- [9] Y. Wen, S. Xiaowei, Q. Rong and Z. Yimen, "26-GHz pHEMT VCO MMIC," *Wiley Microwave and Optical Technology Letters*, vol. 44, pp. 550-552, 2005.
- [10] Q. Zou, M. Kaixue, K. S. Yeo and W. M. Lim, "Design of a Ku-band Low-Phase-Noise VCO Using the Dual LC Tanks," *IEEE Transactions on Circuits and Systems II: Express Briefs*, vol. 59, pp. 262-266, 2012.
- [11] F. Herze, G. Panic, J. Borng"aber, D. Kissinger, "An Integrated VCO with Frequency Tripler in SiGeBiCMOS with a1-dB Bandwidth from 22 GHz to 32 GHz for Multiband 5G Wireless Networks," *12th German Microwave Conference*, 2019.
- [12] G. Cheng, Z. Li, Z. Li, T. Han and M. Tian, "A 22-to-36.8 GHz low phase noise Colpitts VCO array in 0.13- μ m SiGeBiCMOS technology," *Microelectronics Journal*, vol. 88, pp. 79-87, 2019.
- [13] B. Piernas, K. Nishikawa, T. Nakagawa, K. Araki, "A Compact and Low-Phase-Noise Ka-Band pHEMT-Based VCO," *IEEE Transactions on Microwave Theory And Techniques*, vol. 51, pp. 778-783, 2003.
- [14] S. L. Jang, J. C. Hou, B. S. Shih, G. Z. Li, "Low-phase noise 8.22 GHz GaN HEMT oscillator using a feedback multi-path transformer," *Wiley Microwave and Optical Technology Letters*, vol. 61, pp. 1-5, 2018.
- [15] United Monolithic Semiconductors, "Take advantage of wideband, low noise medium power UMS PH15 GaAs process," *Shared Foundry Offer*, 2018.

- [16] M. Ribate, R. Mandry, J. Zbitou, L. El Abdellaoui, A. Errkik and M. Latrach, "A 1.25 GHz – 3.3 GHz broadband solid-state power amplifier for L and S bands applications," *International Journal of Electrical and Computer Engineering (IJECE)*, vol. 9, pp. 3633-3641, 2019.
- [17] A. Hajimiri, and T.H. Lee, "A General Theory of Phase Noise in Electrical Oscillators," *IEEE Journal of Solid-State Circuits*, vol. 33, pp. 179-194, 1998.
- [18] M. Abata, M. Mahmoud, S. Mazer, M. El Bekkali, C. Algani, "A V-band two pole high-pass filter for frequency quadrupler design," *International Journal on Communications Antenna and Propagation*, vol. 6, pp. 56-60, 2016.
- [19] A. Es-Saqy, M. Abata, S. Mazer, M. El Bekkali, Y. Balboul, M. Elghazi, M. Fattah, M. Mehdi and C. Algani, "Design of a MMIC Colpitts VCO for 5G mm-wave band Applications," *The first international conference on smart information & communication technologies*, 2019.
- [20] X. Wang, X. W. Zhu, C. Yu and W. Hong, "Compact and low phase noise oscillator employing multilayer sixteenth-mode substrate integrated waveguide filter for 5G applications," *IEEE Transactions on Components, Packaging and Manufacturing Technology*, vol. 9, pp. 1863-1871, 2019.
- [21] A. Es-Saqy, M. Abata, S. Mazer, M. Mehdi, C. Algani, "comparative study between hartley and colpitts VCO for 5G mm-wave band applications," *The 7th Mediterranean Congress of Telecommunications*, 2019.
- [22] M. H.Kashani, R. Molavi and S. Mirabbasi, "A 2.3-mW 26.3-GHz Gm-boosted differential colpitts VCO with 20% tuning range in 65-nm CMOS," *IEEE transactions on microwave theory and techniques*, vol. 67, pp. 1556-1565, 2019.
- [23] N. Lacaïta, M. Bassi, A. Mazzanti, and F. Svelto, "A K-band low-noise bipolar class-C VCO for 5G backhaul systems in 55 nm BiCMOS technology," *Integration, the VLSI Journal*, vol. 63, pp. 299-305, 2018.
- [24] S. J. Azhari and M. Zareie, "A low voltage low power CMOS implementation of second generation orderly current buffer," *Iranian Journal of Electrical and Electronic Engineering*, vol. 15, pp. 258-268, 2019.
- [25] A. Siddique, T.S. Delwar, M. Kurbanov and J.Y. Ryu, "Low-power low-phase noise VCO for 24 GHz applications," *Microelectronics Journal*, vol. 97, pp. 1-23, 2020.

BIOGRAPHIES OF AUTHORS



Abdelhafid Es-saqy, was born in TISSA, Morocco, in January 1992. Received his Master degree in Microelectronics from faculty of sciences Dhar EL Mahraz Fez Morocco, in 2018. He is now Ph.D. student in Artificial Intelligence, Data Sciences and Emerging Systems Laboratory at the University of Sidi Mohamed Ben Abdellah Fez. His main research interest includes Mixers and Local Oscillators.



Maryam Abata, born in 1989 in Nador, Morocco, obtained Master's degree in 2012 at the National School of Applied Sciences. She received the Ph.D. in Telecommunications and Micro-waves devices from Sidi Mohamed Ben Abdellah University of Fez



Mahmoud Mehdi was born in Beirut, Lebanon, in 1974. He received his Ph.D. in high frequency communication systems from the university of Paris Marne la Vallée, France 2005. He is an associate professor in the Physics Department of the Faculty of sciences at the Lebanese University, Beirut, Lebanon. His research interests include Monolithic Microwave Integrated Circuits (MMIC), Micro-Electro-Mechanical Systems (MEMS), Radiofrequency, Double Balanced and Distributed Mixers, Local Oscillator, TW Amplifiers, Optoelectronic Mixer for LIDAR system, Optical systems and design, and Photo-detectors. He is course leader in microwave devices for the Masters program in Electronics



Said Mazer, born in 1978. PhD in electronics and signal processing at the University of Marne-La-Vallée. Currently professor at the National School of Applied Sciences of Fez, Morocco and he is a member of Artificial Intelligence, Data Sciences and Emerging Systems Laboratory at the University of Sidi Mohamed Ben Abdellah Fez.



Mohammed Fattah, received his Ph.D. in Telecommunications and CEM at the University of Sidi Mohamed Ben Abdellah (USMBA) Fez, Morocco, 2011. He is a professor in the Electrical Engineering Department of the High school of technology at the Moulay Ismail University (UMI), Meknes, Morocco and he is member of the team research 'Information Processing and Transmission', LIA laboratory, UMI.



Moulhime El Bekkali, received the PhD. degree in 1991 from the USTL University Lille 1, France, he worked on X-band printed antennas and their applications to microwave radar. He is a professor in the Electrical Engineering Department of Superior School of Technology, Fez (ESTF). He is member of Artificial Intelligence, Data Sciences and Emerging Systems Laboratory. Since 2009, Pr. El Bekkali served as vice President at University of Sidi Mohamed Ben Abdellah (USMBA) Fez, Morocco.



Catherine Algani, born in 1963. PhD in electronics at the University Pierre and Marie Curie (Paris VI). University professor at the National Conservatory of Arts and Crafts, CNAM-Paris. She is the responsible of the research team "communication systems" at ESYCOM laboratory.