

## Analysis of fuzzy logic controller based bi-directional DC-DC converter for battery energy management in hybrid solar/wind micro grid system

M. Nagaiah<sup>1</sup>, K. Chandra Sekhar<sup>2</sup>

<sup>1</sup>Department of Electrical and Electronics Engineering, Acharya Nagarjuna University, Guntur, India

<sup>2</sup>Department of Electrical and Electronics Engineering, RVR&JC College of Engineering, Guntur, India

---

### Article Info

#### Article history:

Received Sep 25, 2019

Revised Nov 24, 2019

Accepted Dec 9, 2019

---

#### Keywords:

Battery system  
Energy management  
Micro grid  
MPPT  
PV system  
Wind system

---

### ABSTRACT

This paper proposes a fuzzy logic-based battery energy management system in hybrid renewable system. The novel topology consists of solar and wind energy system-based input sources and a battery bank to store the energy when in excess. The PV-Wind source is equipped with unidirectional boost converter whereas, the battery storage system is connected to the system with a bi-directional DC/DC converter. The main novelty of this research is the fuzzy logic-based battery management system which charges and discharges into the DC bus system based on the supply-load demand. The fuzzy logic controller (FLC) based maximum power point tracking (MPPT) is used in the PV and wind energy conversion system (WECS) to track the maximum available power for the different irradiance and wind velocity respectively. The obtained results are compared to conventional P&O MPPT control algorithm to find the effectiveness of the system. A 500 W PV system and a 500 W Permanent magnet synchronous generator (PMSG) based WECS is implemented for its simplicity and high efficiency. The proposed control topology is designed and tested using MATLAB/Simulink.

Copyright © 2020 Institute of Advanced Engineering and Science.  
All rights reserved.

---

### Corresponding Author:

M. Nagaiah,  
Department of Electrical and Electronics Engineering,  
Acharya Nagarjuna University, Guntur, India.  
Email: mandava.naga@gmail.com

---

## 1. INTRODUCTION

Rapid increase in population and urbanisation resulted in increase in demand of energy all over the world. At present the major source of energy is dominated by fossil fuel [1, 2]. The constant depletion of fossil fuel and its negative impact on the environment tends to opt for an alternative source of power generation. Renewable energy generation is gaining lot of attention in order to overcome the drawbacks of fossil fuel. Renewable energy sources include solar, wind, tidal, wave, and biomass. Since solar and wind are widely available in abundant, they are used for power generation [3, 4]. The reliability of solar and wind energy is highly depending upon the climatic changes and unpredictable nature [5-7]. Thus, it causes serious concern of grid integration. To overcome the issue, need of hybridization of renewable sources and energy storage is viable option to extract quality power from renewable based generation [8, 9].

The hybrid renewable energy-based generation compasses of variable renewable energy and storage elements combination based on the availability and need [10,11]. The hybrid energy system can be of standalone or grid connected system. The standalone system is generally termed as the micro-grid which meets the demand of local loads which is equipped with the power electronics interface to ensure proper load sharing [12-14]. Standalone system requires a high rating and sufficient energy storage device to cope with the variable power generated by the renewable sources. The grid connected system of the hybrid renewable system is the extension of the micro-grid. The ratings of the energy storage device can be minimised since the grid provide a sufficient backup to low power generation. Since, the renewable based generation is highly

non-linear in nature; the grid compatibility is the major concern. The regulation such as voltage, frequency and harmonics must strictly adhere to the policy to ensure better utilisation of source and protect the loads connected to the system. Thus, an efficient control strategy is required to integrate the renewable sources to the grid.

In this paper, a hybrid PV-Wind based renewable energy is considered as the source. The output of the PV array and wind system is connected to the boost converter in order to maximise the voltage to match the DC-bus parameter. The hybrid system is connected to the common DC-bus system which also consists of the battery storage system connected through bi-directional DC-DC converter to provide both charging and discharging operation. The common dc bus system is utilised in this manuscript in order to integrate the PV and wind source along with energy storage system. The boost converter of the system is controlled using the maximum power point tracking methodology. The main objective of the paper is to supply un-interruptible power to the load despite of the variable power generation. Ensure the proper charging of the battery during excess power generation and to discharge during low power production. The constant DC link voltage for the dc bus system is also an important parameter of the proposed topology. The basic topology considered for this research is shown in Figure 1.

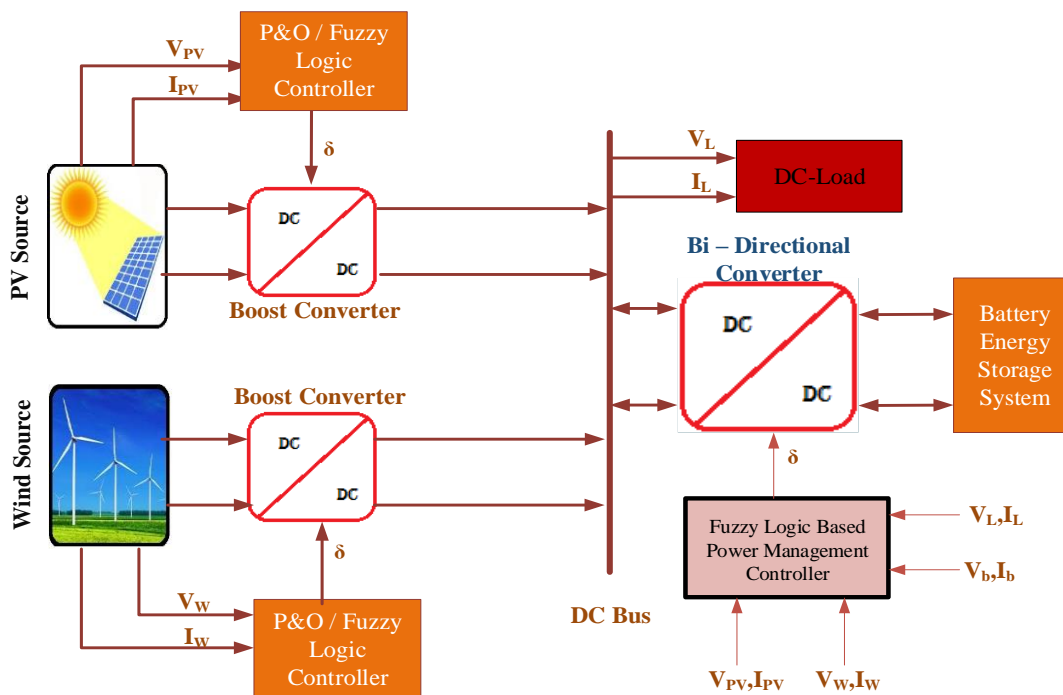

Figure 1. Basic Topology of the Proposed System

## 2. MODELLING OF HYBRID SYSTEM

### 2.1. Fuzzy based MPPT for PV system

Fuzzy logic control is better than the conventional control algorithms particularly for complex processes that could not be analyzed using conventional quantitative techniques. It is non-linear as well as adaptive and it is a real alternative for a range of control applications. There are four chief essentials in the structure of FLC armed as fuzzifier, Rule base, Inference engine and defuzzifier [15-17]. The functioning of fuzzy controller's structure can be effortlessly understood from the figured is played in Figure 2.

- Fuzzification: In this procedure, the crisp set used as input data is transformed into a fuzzy set by means of fuzzifier using linguistic variables, fuzzy linguistic terms as well as membership functions. The furthestmost imperative thing concerning fuzzy logic is that an arithmetical value doesn't have to be fuzzified using only one membership function. The Membership functions differ as Triangular, Gaussian, Trapezoidal, and Generalized Bell in addition to Sigmoid.
- Rule Base: The initiative of rule base is to govern the output variable. The rule is simple IF-THEN rule with an exact condition and conclusion, characterized by the matrix table. Error and alteration in error are

the two variables occupied along the axes, and the conclusions are within the table. The output of membership function in the rule base is well-defined as least and extreme operator. The fuzzy rule base is typically influenced by the change in input.

- **Defuzzification:** The control of non-fuzzy value can be obtained by the defuzzification from the fuzzy set output of the fuzzy controller. The output of the fuzzy controller is duty cycle, which is used to control the boost converter operation. Benefits of Fuzzy Controller are Low-cost executions founded on cheap sensors, low-resolution analog-to-digital converter. At the point of MPPT, error signal E should be zero to maintain the maximum power point. For the fine tuning, the variation in error signal is defined ΔE which is the second signal to the fuzzy agent. Error signal E and change in error signal ΔE can be defined as in (1) and (2),

$$E(i) = \frac{P_{pv}(i) - P_{pv}(i-1)}{V_{pv}(i) - V_{pv}(i-1)} \tag{1}$$

$$\Delta E(i) = E(i) - E(i-1) \tag{2}$$

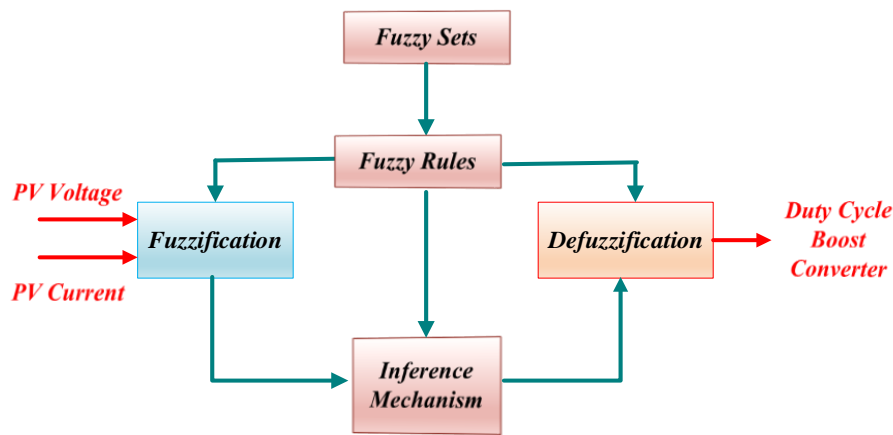

Figure 2. Fuzzy Logic control circuit for Boost Converter

The fuzzy agent can control the duty cycle of the DC- DC converter in order to get the maximum power point tracking and the DC- DC converter boosts up the voltage level depending upon duty-cycle. As shown in Table 1, the input and output variables are expressed in seven linguistic labels such as negative large (NL), positive large (PL), negative medium (NM), positive medium (PM), zero (Z), negative small (NL) and positive small (PL). If the E is NL and ΔE is NL, the duty cycle is PL, such that the duty cycle is largely increased and the similar manner for all the membership functions. The fuzzy rule base is shown in Table 1 and the membership functions of the FLC are shown in Figures 3-5 respectively.

Table 1. Fuzzy rules for PV system

$E/\Delta E$	NL	NM	NS	Z	PS	PM	PL
NL	PL	PL	PL	PL	NM	Z	PL
NM	PL	PL	PM	PL	PS	Z	Z
NS	PL	PM	PS	PS	PS	Z	Z
Z	PL	PM	PS	Z	NS	NM	NL
PS	Z	Z	NM	NS	NS	NM	NL
PM	Z	Z	NS	NM	NL	NL	NL
PL	Z	Z	NM	NL	NL	NL	NL

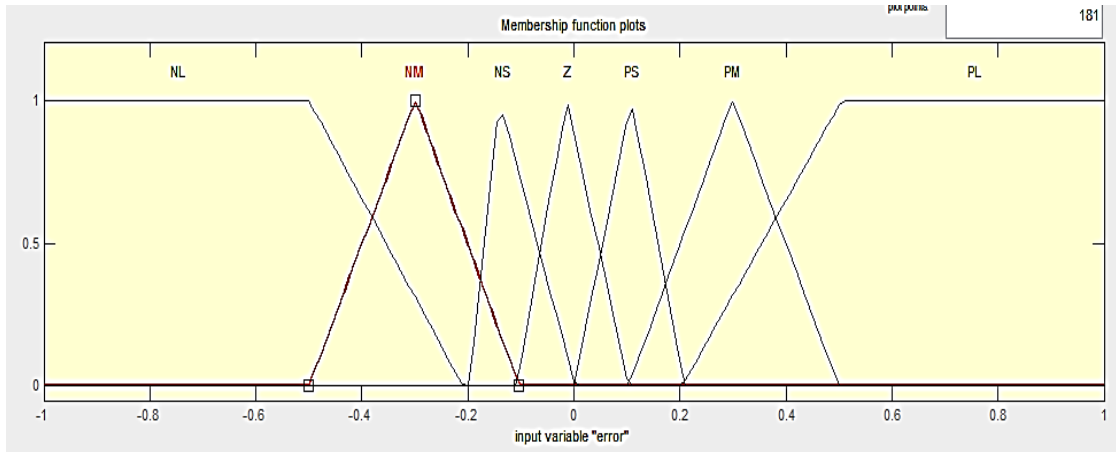

Figure 3. Input Voltage of FLC

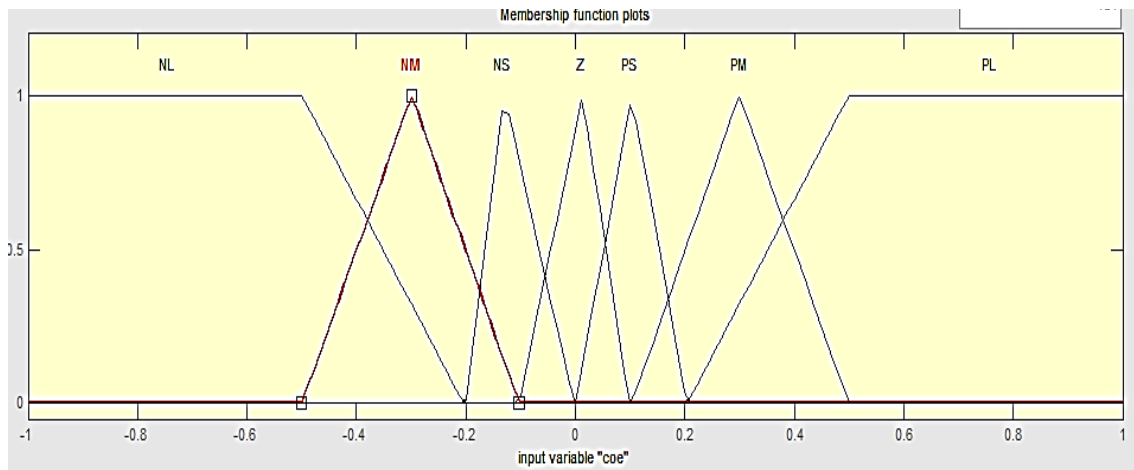

Figure 4. Input Current of FLC

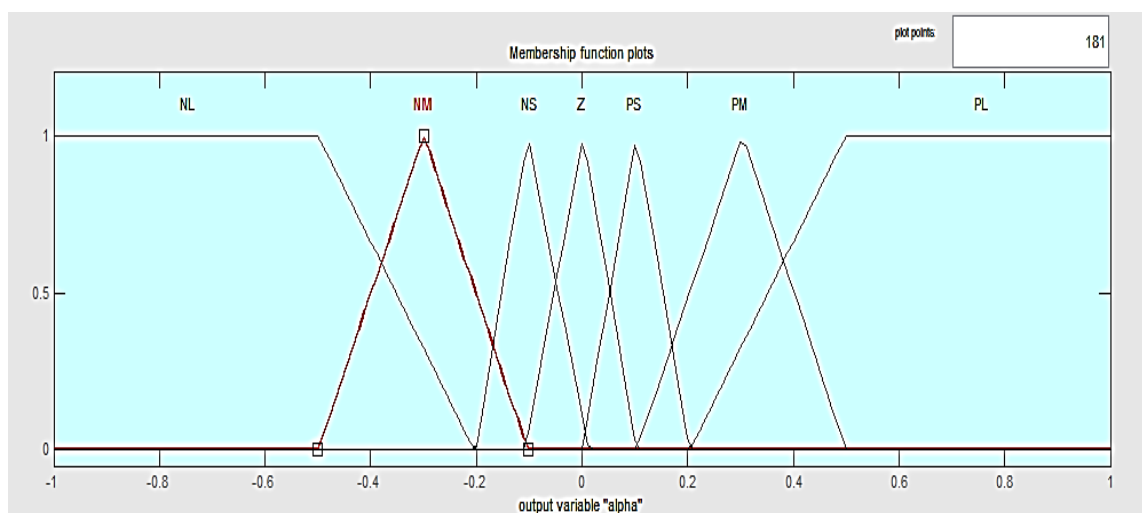

Figure 5. Output membership function (Duty Cycle) of FLC

**2.2. Fuzzy logic based MPPT for WECS**

Fuzzy Logic Controller (FLC) has an advantage of fast convergence, imprecise input and handling non linearity. FLC generally consist of three stages Fuzzification, Rule base lookup table and Defuzzification as shown in Figure 6. The rules are designed on the basis of previous knowledge of the system. An FLC is the artificial decision-making controller that operates in closed loop. The inputs for fuzzy controllers are error signal and change in error signal. Once the signals are calculated and linguistic variables are obtained, the output of FLC is the duty cycle for buck converter is which is generated using the rules. FLC is termed to be the most efficient MPPT controller when compared with the PI and P&O controller [18-20]. The efficiency of FLC is purely depending upon the previous knowledge of the system and right error computation and framing of rule-based table. Table 2, represents the set of rules used for modelling FLC. Where, E represents the error signal and CE represents the Change in error. The rules are framed in five level namely Negative Big (NB), Negative Small (NS), Zero (ZE), Positive Small (PS) and Positive Big (PB).

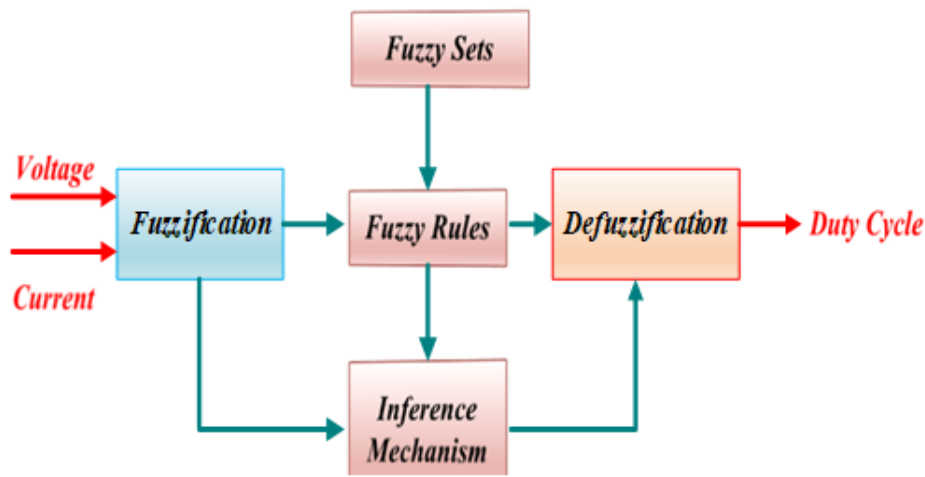

Figure 6. Basic structure of FLC

Inference mechanism is basically defined by membership functions of FLC which determines the relevance of rules from Table 2. Figures 7-9 represents the input and output membership function of FLC controller. Methods for implication and aggregation are defined as Minimum (min) and Maximum (max) respectively. The Defuzzification method uses centroid for processing. FLC tracks the sudden change in wind speed more swiftly and precisely. The maximum power point is traced by the controller from the inference system which is mapped by the human knowledge earlier in form of rules. The controller tracks the change in output voltage, current and generates an error signal which is given as an input for fuzzification process, here the input data is converted into a suitable fuzzy linguistic set using Mamdani method. Then the fuzzy set is processed in inference system where an appropriate fuzzy output is obtained using fuzzy rules. Then the fuzzy output is converted in to the systematic crisp value as a form of duty cycle in defuzzification. Thus, the duty cycle is used to control the switching pattern of the converter switch.

Table 2. FLC set of rules

E/CE	NB	NS	ZE	PS	PB
NB	ZE	PB	ZE	NB	NS
NS	PS	ZE	ZE	NB	NS
ZE	ZE	ZE	ZE	ZE	ZE
PS	PS	PB	ZE	ZE	NS
PB	PS	PB	ZE	NB	ZE

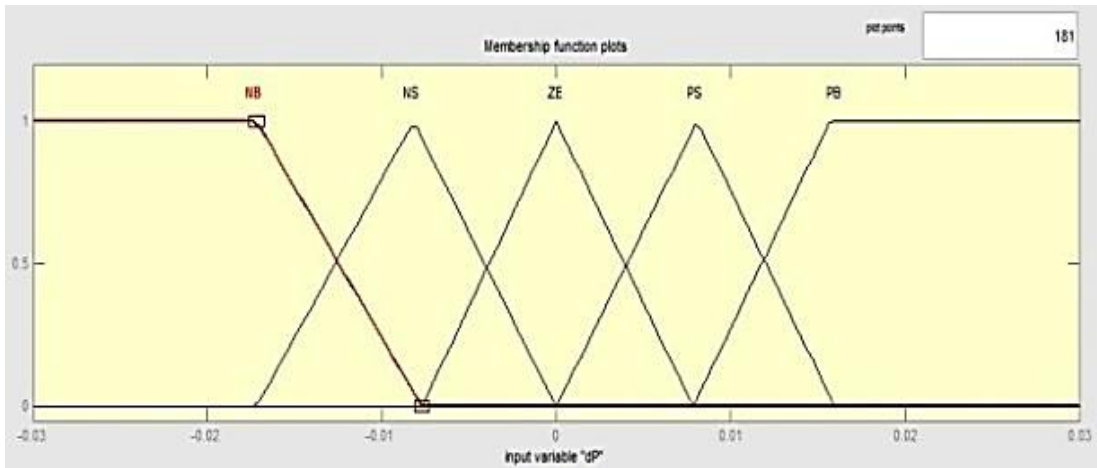

Figure 7. Input membership function of generated voltage

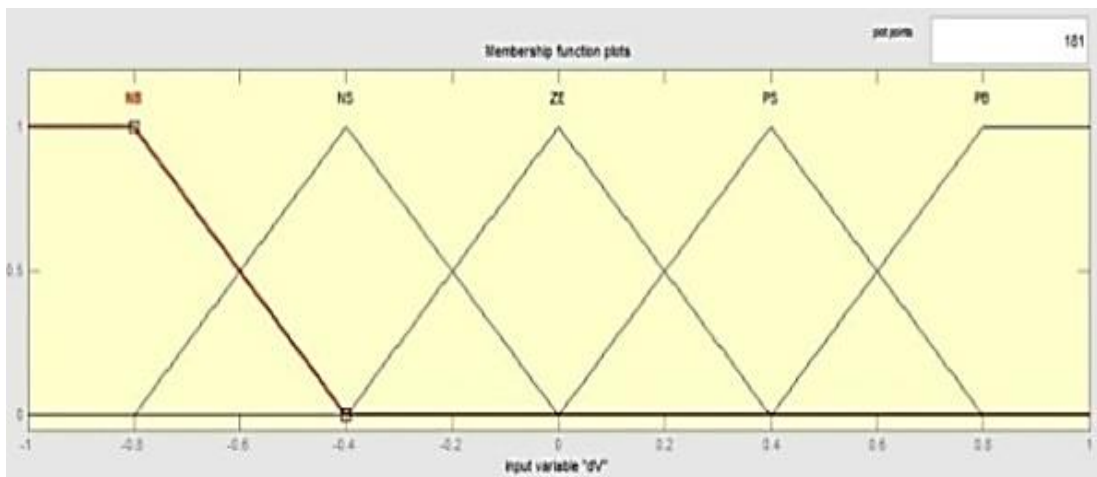

Figure 8. Input membership function of generated current

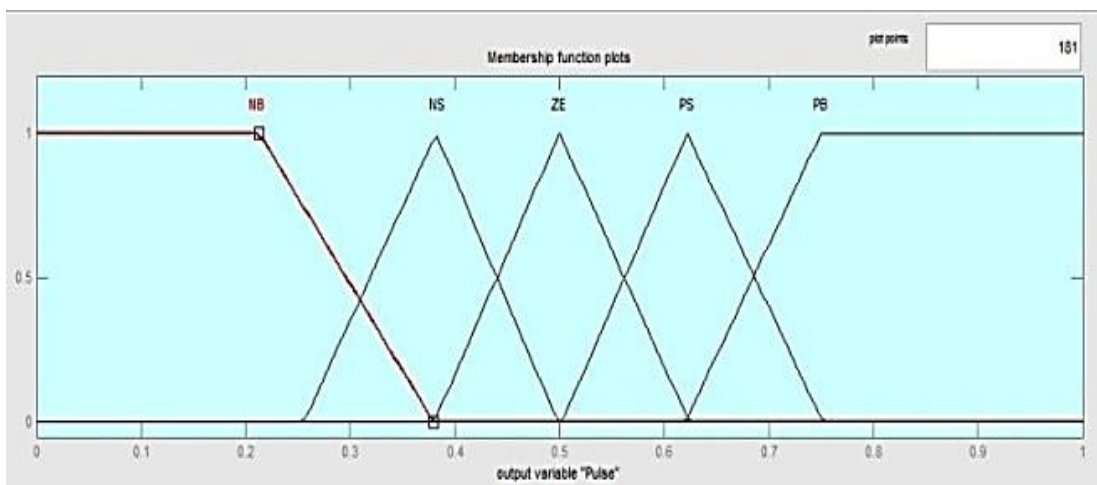

Figure 9. Output membership function of duty cycle

### 3. FUZZY LOGIC BASED BATTERY MANAGEMENT SYSTEM

The battery management system (BMS) is proposed in order to maintain the DC bus voltage constant. The BMS strategy is utilised to fulfil the load demand irrespective of the changes in input source [21]. The battery is connected to the DC bus using bi-directional DC/DC converter. The fuzzy logic-based power flow control strategy is designed for proposed standalone system. The FLC based BMS system is designed using the pre knowledge of the source, availability of power and load demand. The FLC based BMS system robust in nature and highly reliable. As stated earlier the fuzzy logic controller consists of three processes, fuzzification, rule-based design and defuzzification. The fuzzification process consists of input of error of Power and change in power. The rule of the system is designed as follows:

- The power of PV and Wind energy is calculated and allowed to generate as much power as possible.
- When there is excess power generated from the renewable energy sources, the battery is end to charge until the maximum threshold voltage so as to maintain the battery for longer span.
- When there is low power generate from the source, the battery acts an external source to meet the load demand.

The rule system produces an optimum duty cycle in order to keep the dc bus voltage constant always and also to meet the load requirement in all weather condition. The duty ratio of the bi-directional DC/DC converter is generated based on the rules and the input parameters. The defuzzification is process to change the fuzzy sets to the duty cycle. The control block diagram of FLC is shown in Figure 10.

In proposed controller, the error of generator power  $\Delta P$  and change in power error  $\delta$  ( $\Delta P$ ) are the input variable. The output of the FLC based controller is duty cycle [22]. The  $\Delta P$  and  $\delta(\Delta P)$  are defined as in (3) and (4):

$$\Delta P(k) = P_g - P_{ref}(k) \quad (3)$$

$$\delta(\Delta P) = \Delta P(k) - \Delta P(k-1) \quad (4)$$

the membership functions of the fuzzy sets for the proposed system are represented by the linguistic variables. The variables are represented by Negative Big (NB), Negative Small (NS), Zero (ZE), Positive Small (PS), and Positive Big (PB).

The control rules are derived from the experience and knowledge on the control system and the rules for mapping of input and out variables of FLC. In this paper, fuzzy uses Mamdani type inference system. The input and output variable are generated using triangular membership function as shown in Figure 11. Figure 11 (a) and (b) and Figure 12 represent the input and output membership function of FLC controller respectively. Methods for implication and aggregation are defined as Minimum (min) and Maximum (max) respectively. The Defuzzification method uses centroid for processing.

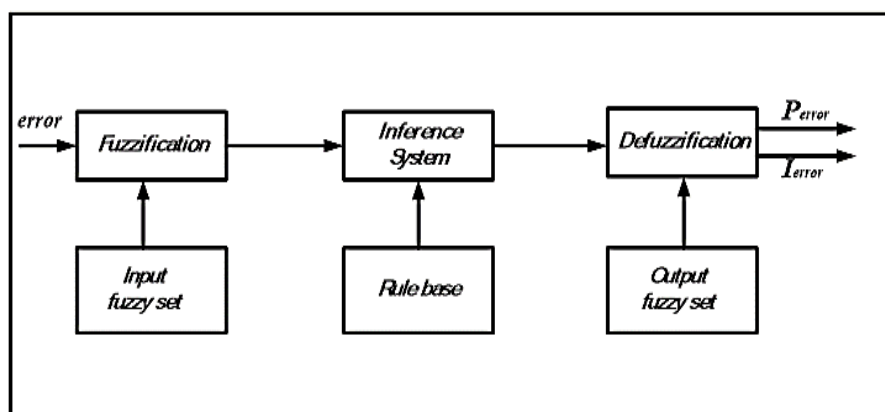

Figure 10. FLC based battery management system

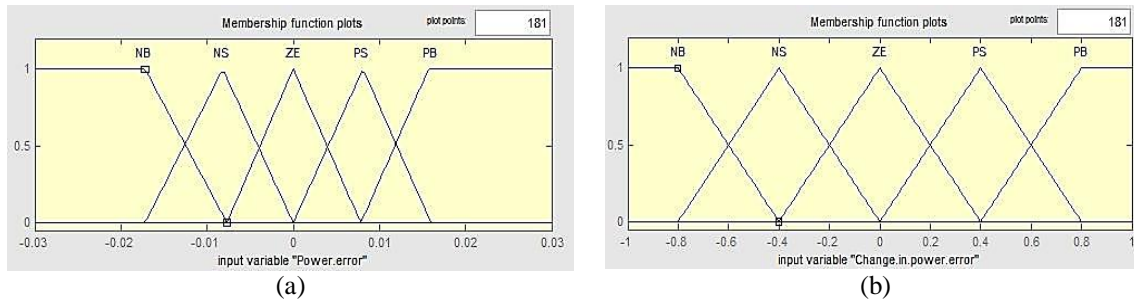

Figure 11. Input membership function, (a) error signal (b) change in error signal

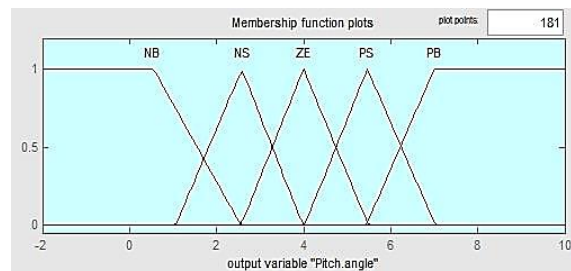

Figure 12. Output membership function of duty cycle

**4. MODELING OF DC/DC CONVERTER**

The converter is employed in WECS in order to enhance the generated voltage to the desired high voltage as per the load requirement. The DC/DC converter implemented in this paper is boost converter which is used to boost generator voltages to 380 V which is the standard bus voltage for DC microgrid. In this paper, a bi-directional DC-DC converter is utilised to raise the terminal voltage to achieve the flexible control of the battery energy storage system (BESS). To overcome the drawback of low voltage of battery system, a phase shifted full bridge DC-DC converter is used to connect the battery source to AC grid. The bidirectional converter consists of high frequency transformer which is required to match the AC grid and battery voltage level. The bidirectional converter consists of leakage inductance and output filter inductance. When BESS is charging state, bidirectional converter acts as the buck converter by controlling the switches I<sub>1</sub>–I<sub>4</sub>. When the BESS is in discharging state, the bidirectional converter acts as a boost converter by controlling the switches C<sub>1</sub>–C<sub>4</sub>.

The converter topology chosen for the proposed work is depicted in Figure 13. During the standalone operation of renewable energy source like PV, smooth and continuous power flow is affected by its intermittent nature. The possible solution was to permit energy exchange between the converter to the storage system and the converter to the load. The evolution of bidirectional DC-DC converters could find its way classified in the literature as isolated and non-isolated. The isolated bidirectional DC-DC converters gained prominence due to its voltage matching and galvanic isolation provided by means of a transformer. The bidirectional converter proposed in the research work [23] features series resonance and boost capability with simple PWM. The isolated bidirectional converter proves to be much better when assessed based on attributes like high efficiency, high gain, and the number of switches [24]. The PV integration improves the utilization of the converter through its voltage boosting capability, which is enhanced further by the transformer [25].

The hybrid converter resembles an isolated resonant converter, except for the active bidirectional switch (S<sub>5</sub>) at the secondary side of the galvanic isolation transformer. The design of transformer, resonant inductor L<sub>r</sub>, resonant capacitors C<sub>r1</sub>, C<sub>r2</sub>, and the gating scheme is adapted from the literature. The design procedure involves selection of transformer turns ratio and the design of the resonant tank. Turns ratio of transformer is given by (5):

$$n = \frac{V_o}{2V_{in}} \tag{5}$$



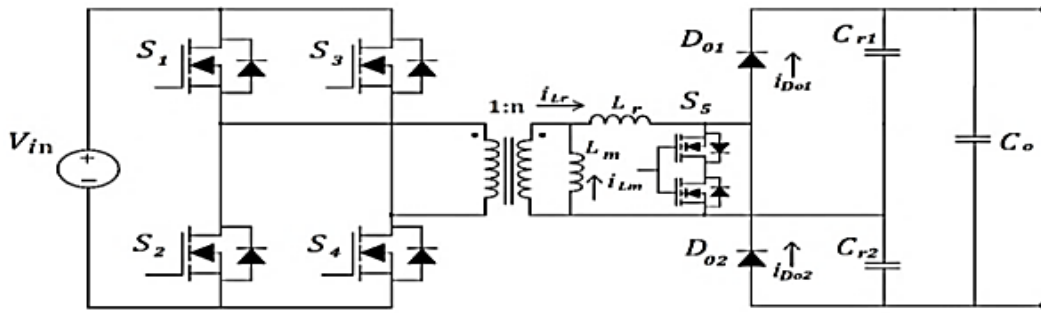

Figure 13. Isolated Bidirectional DC-DC Converter

In the resonant tank design, the resonant inductor  $L_r$  is independent of the conversion ratio since it acts as boost inductor. A large enough inductor was chosen based on the longer switching state of PWM boost mode and the resonant mode. The length of switching time is less than switching periods  $T_s$  of all operating ranges. The  $L_r$ ,  $C_r$ ,  $L_m$  should be chosen such that they satisfy the equations from (6) to (8).

$$C_r > \frac{P_o T_s}{V_o^2} \tag{6}$$

$$L_r > \frac{V_o^2}{2\omega_r^2 P_o T_s} \tag{7}$$

$$L_m \leq \frac{n^2 T_{DT}}{4C_o f_s} \tag{8}$$

The resonant capacitance can also be chosen based on the resonant frequency  $\omega_r$ , from (9)

$$\omega_r = 2\pi f_r = \frac{1}{\sqrt{L_r(C_{r1} + C_{r2})}} \tag{9}$$

**5. RESULTS AND DISCUSSION**

The performance of the proposed FLC based battery management system is validated in the MATLAB/Simulink software. From the literature, the availability of both solar and wind energy sources is alternative to each other and to check the feasibility of the developed converter operation in both individual and simultaneous modes, the availability of the renewable energy sources are considered as follows. For the period 0 to 0.75 sec, the availability of wind source is 8 m/s and the PV irradiation is 600 W/m<sup>2</sup>. Similarly, for period of 0.75 to 1.5 sec and 1.5 to 2.25 sec are wind velocity 10m/s with PV irradiation of 800 W/m<sup>2</sup> and wind velocity 12 m/s with 1000 W/m<sup>2</sup> respectively as shown in Figure 14 and Figure 15.

The proposed hybrid system considered for this analysis is 500 W PV and 500 W wind systems for 1kW hybrid system and parameter specifications are listed in Table 3. The battery parameter used in this is study is also shown in Table 3. The proposed topology consists of FLC based MPPT control strategy for PV application. The DC voltage, current and power obtained using FLC based MPPT strategy employed for PV system is shown in Figure 16. The FLC control strategy has a good dynamic response to the non-linear system. The performance of the FLC based MPPT technique for WECS is shown in Figure 17. The wind velocity is highly nonlinear in nature thus an efficient control strategy is required to obtain the maximum available power from the wind velocity.

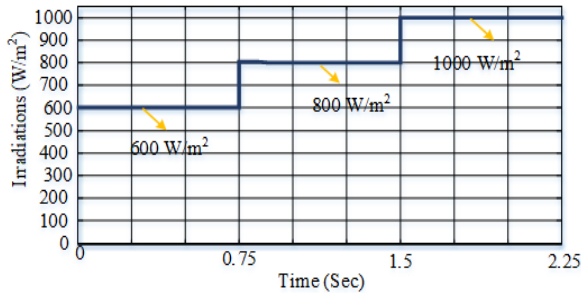

Figure 14. PV irradiance (W/m<sup>2</sup>)

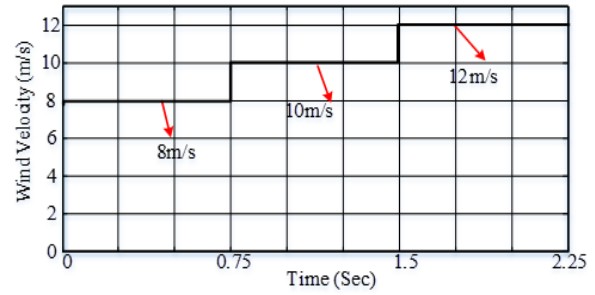

Figure 15. Wind speed (m/s)

Table 3. Hybrid system parameters

Solar system		Wind System		Battery	
Parameters	Values	Parameters	Values	Parameters	Values
$V_{MP}$	48 V	Wind speed Nominal	12 m/s	Type	Lithium Ion
$I_{MP}$	10.4 A	PMSG Motor	500 W	Nominal voltage	48 V
Solar irradiance	1000 W/m <sup>2</sup>	Stator phase resistance	0.425 Ohms	Rated capacity	6.5 AH
Temperature	25 <sup>o</sup> c	D axis inductance	0.0082 H	Soc at charging	30%
Cells in module	60	Q axis inductance	0.0082 H	Soc at discharging	80%
s	8	Number of poles	5		
$N_p$	5	Motor inertia	0.01197 kg.m <sup>2</sup>		
$R_s$	0.18 Ohms				
$R_p$	360 Ohms				
Ideality factor	1.7				

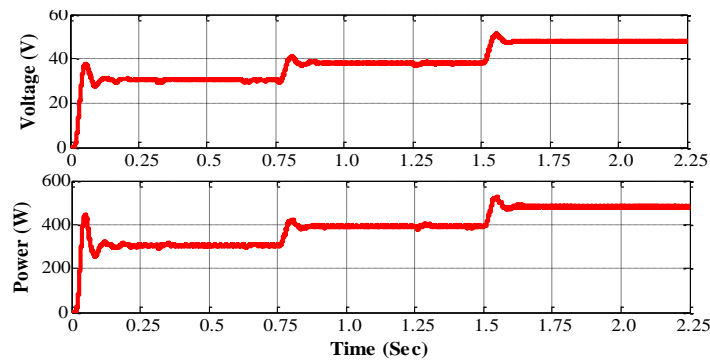

Figure 16. PV system output voltage, power

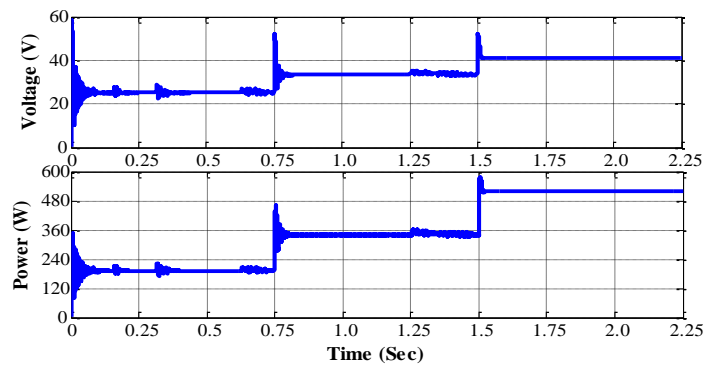

Figure 17. Wind system output voltage and power

The overall DC link Power of the hybrid system is shown in Figure 18. The DC link voltage of 380 V is constant for the variable irradiance and wind velocity. The rated power of 1 kW is achieved by combining the both sources. The Figure 19 shows the DC link power of hybrid system under different solar irradiation and wind speed data, the FLC based MPPT algorithm gives the at most efficiency of hybrid system when compare to the conventional P&O MPPT controller.

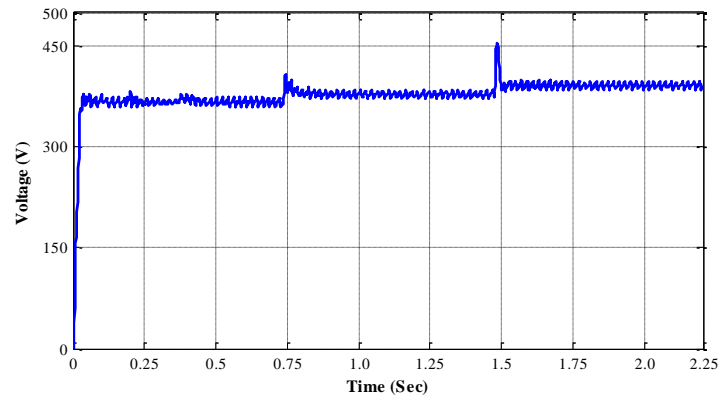

Figure 18. DC link voltage

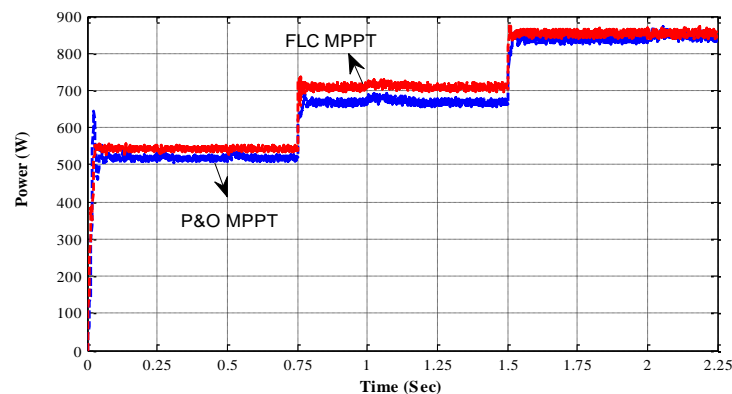

Figure 19. DC link power

The battery source is connected to the DC bus using bi-directional DC/DC converter. The battery is charged when the load demand is low and there is excess power whereas, the battery supports the DC bus system when the load demand is high. The load demand of 700W is considered for this study. The Figure 20 shows the power sharing between the renewable energy sources and battery energy system to meet the load demand of 700 W throughout the time period from 0 to 2.25 sec as per the consideration of renewable energy sources input. Figure 21 and 22 shows the SOC of lithium ion battery and battery voltage respectively.

Table 4 gives the comparatively analysis of hybrid system with different MPPT control algorithm to track the maximum power from the hybrid renewable PV and wind system. Among P&O and FLC MPPT technique, FLC technique gives the higher efficiency of 85.6 % compared to the P&O MPPT controller which is 82.4 %. The power sharing between the renewable energy sources and battery to meet the load power demand is managed by using FLC controller. The effective load sharing is presented in the Table 4 under different time durations with the considered renewable energy source input.

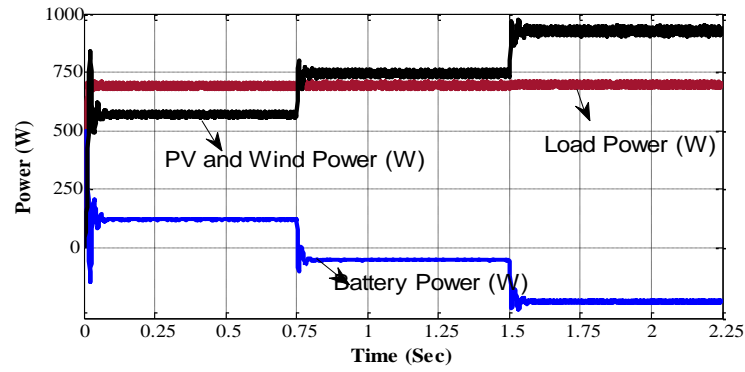

Figure 20. Hybrid system output with power sharing

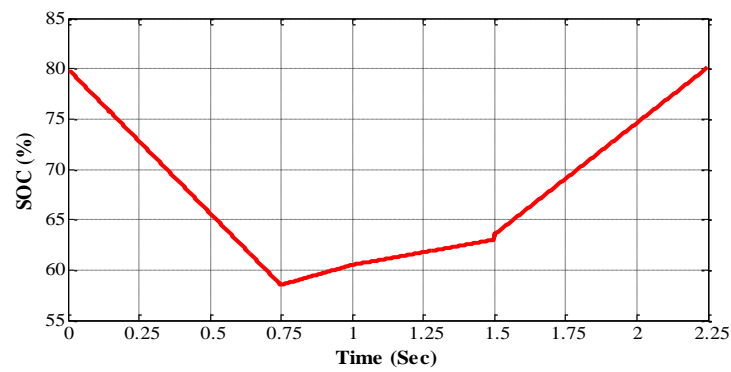

Figure 21. SOC of lithium ion battery

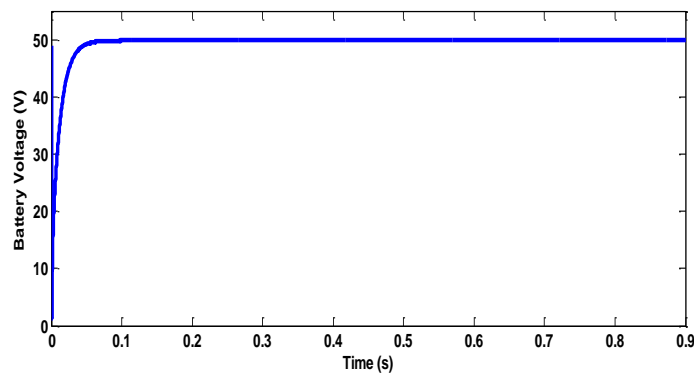

Figure 22. Battery voltage

Table 4. Comparative table of hybrid system with different MPPT control algorithms

		Hybrid PV and wind 1 kW system		
Time (Sec)		0 to 0.75	0.75 to 1.5	1.5 to 2.25
Solar irradiations		600 W/m <sup>2</sup>	800 W/m <sup>2</sup>	1000 W/m <sup>2</sup>
Wind velocity		8 m/s	10 m/s	12 m/s
Voltage (V)		380	380	380
Power (W)	P&O MPPT	528.3	674	824
	Fuzzy MPPT	552	708	856
Load Demand (W)		700	700	700
Battery Power (W)		148	-8	-156

## 6. CONCLUSION

The developed 1 kW hybrid System with battery storage unit is designed in MATLAB/Simulink environment. The performance of the proposed system is validated by considering the different solar and wind input under different time durations with the constant 700 W load power demand. To meet this load, demand an effective FLC is implemented to operation of bidirectional converter in charging and discharging mode to share the power between the renewable energy sources and battery while meeting the load power demand. A comparative study has been done in maximum power extraction from renewable energy sources with P&O and FLC MPPT controllers. The FLC controller gives the much higher efficiency of 85.6% compare to the conventional P&O MPPT controller which is 82.4 %. The same FLC control strategy is to be implemented in future for AC-DC Bidirectional inverter between DC Bus and AC main grid structure.

## REFERENCES

- [1] Tiwari, Ramji, and N. Ramesh Babu., "Recent developments of control strategies for wind energy conversion system," *Renewable and Sustainable Energy Reviews* 66, pp. 268-285, 2016.
- [2] Wu, Zhou, HenericaTazvinga, and Xiaohua Xia., "Demand side management of photovoltaic-battery hybrid system," *Applied Energy*, vol. 148, pp. 294-304, 2015.
- [3] Tiwari, Ramji, Kumar Krishnamurthy, Ramesh Babu Neelakandan, Sanjeevikumar Padmanaban, and Patrick William Wheeler., "Neural network based maximum power point tracking control with quadratic boost converter for PMSG—wind energy conversion system," *Electronics*, vol. 7, no. 2, pp. 1-20, 2018.
- [4] Torreglosa, Juan P., et al., "Energy dispatching based on predictive controller of an off-grid wind turbine/photovoltaic/hydrogen/battery hybrid system," *Renewable Energy*, vol. 74, pp. 326-336, 2015.
- [5] Kumar, D. Dinesh, Challa Babu, K. Jyotheeswara Reddy, K. Kumar, and N. K. Kumar. "An improved P&O MPPT control algorithm for increasing power extraction efficiency of solar PV module." *In IOP Conference Series: Materials Science and Engineering*, vol. 623, no. 1, p. 012020. IOP Publishing, 2019.
- [6] Kiran, Shaik Rafi. "Analysis of Solar Photovoltaic Source Fed BLDC Motor Drive with Double Boost Converter for Water Pumping Application in Irrigation System." *International Journal of Advanced Science and Technology* 120, no. 1, 73-84, 2018.
- [7] Badawi, Ahmed, Nurul Fadzlin Hasbullaha, Siti Yusoff, Sheroz Khan, Aisha Hashim, Alhareth Zyoud, and Mohammed Elamassie. "Evaluation of wind power for electrical energy generation in the mediterranean coast of Palestine for 14 years." *International Journal of Electrical and Computer Engineering (IJECE)* 9, no. 4, 2212-2219, 2019.
- [8] Kumar, K., N. Ramesh Babu, and K. R. Prabhu., "Design and analysis of an integrated Cuk-SEPIC converter with MPPT for standalone wind/PV hybrid system," *International Journal of Renewable Energy Research (IJRER)*, vol. 7, no. 1, pp. 96-100, 2017.
- [9] Hossain, Monowar, Saad Mekhilef, and Lanre Olatomiwa., "Performance evaluation of a stand-alone PV-wind-diesel-battery hybrid system feasible for a large resort center in South China Sea, Malaysia" *Sustainable cities and society*, vol. 28, pp. 358-366, 2017.
- [10] Saravanan, S., and N. Ramesh Babu., "Maximum power point tracking algorithms for photovoltaic system—A review," *Renewable and Sustainable Energy Reviews*, vol. 57, pp. 192-204, 2016.
- [11] Phiri, S. F., and K. Kusakana., "Demand Side Management of a grid connected PV-WT-Battery hybrid system," IEEE Xplore: Industrial and Commercial Use of Energy (ICUE), International Conference, 2016.
- [12] Kumar, K., N. Ramesh Babu, and K. R. Prabhu., "Design and analysis of RBFN-based single MPPT controller for hybrid solar and wind energy system," *IEEE Access*, vol. 5, pp. 15308-15317, 2017.
- [13] Ogunjuyigbe, A. S. O., T. R. Ayodele, and O. A. Akinola, "Optimal allocation and sizing of PV/Wind/Split-diesel/Battery hybrid energy system for minimizing life cycle cost, carbon emission and dump energy of remote residential building." *Applied Energy*, vol. 171, pp. 153-171, 2016.
- [14] Kumar, K., "Design and analysis of modified single P&O MPPT control algorithm for a standalone hybrid solar and wind energy conversion system," *Gazi University Journal of Science*, vol. 30, no. 4, pp. 296-312, 2017.
- [15] Alajmi, Bader N., Khaled H. Ahmed, Stephen J. Finney, and Barry W. Williams., "Fuzzy-logic-control approach of a modified hill-climbing method for maximum power point in microgrid standalone photovoltaic system," *IEEE transactions on power electronics*, vol. 26, no. 4, pp. 1022-1030, 2011.
- [16] Tiwari, Ramji, SanjeevikumarPadmanaban, and Ramesh BabuNeelakandan, "Coordinated control strategies for a permanent magnet synchronous generator-based wind energy conversion system," *Energies*, vol. 10, no. 10, pp. 1493, 2017.
- [17] Tiwari, Ramji, and N. Ramesh Babu., "Fuzzy logic based MPPT for permanent magnet synchronous generator in wind energy conversion system," *IFAC-PapersOnLine*, vol. 49, no. 1, pp. 462-467, 2016.
- [18] Tiwari, Ramji, N. Ramesh Babu, SanjeevikumarPadmanaban, Luigi Martirano, and PierluigiSiano., "Coordinated DTC and VOC control for PMSG based grid connected wind energy conversion system," *In Environment and Electrical Engineering and 2017 IEEE Industrial and Commercial Power Systems Europe (EEEIC/I&CPS Europe), 2017 IEEE International Conference on*, pp. 1-6. IEEE, 2017.

- [19] Kumar, K., RamjiTiwari, N. Ramesh Babu, and K. R. Prabhu., "Analysis of MISO Super Lift Negative Output Luo Converter with MPPT for DC Grid Connected Hybrid PV/Wind System," *Energy Procedia*, vol. 145, pp. 345-350, 2018.
- [20] Sivanagaraju, S. V., K. Kumar, and K. Rajasekharachari., "Performance Comparison of Variable Speed Induction Machine Wind Generation System with and Without Fuzzy Logic Controller." *International Journal of Innovative Research and Development*, vol. 2, no. 7, 2013.
- [21] Rajasekharachari, K., G. Balasundaram, and K. Kumar., "Implementation of a battery storage system of an individual active power control based on a cascaded multilevel pwm converter," *Int J Inno Res SciEngTechnol*, vol. 2, no. 7, 2013.
- [22] Tiwari, Ramji, S. Saravanan, Gaurav Kumar, and Vivek Siwach., "Design and development of a high step-up DC-DC Converter for non-conventional energy applications," In *Power and Energy Systems: Towards Sustainable Energy (PESTSE)*, pp. 1-4. IEEE, 2016.
- [23] Zhao, Biao, Qiang Song, Wenhua Liu, and Yandong Sun., "Overview of dual-active-bridge isolated bidirectional DC-DC converter for high-frequency-link power-conversion system," *IEEE Trans. Power Electron*, vol. 29, no. 8, pp. 4091-4106, 2014.
- [24] Mi, Chunting, HuaBai, Chongwu Wang, and Sonya Gargies., "Operation, design and control of dual H-bridge-based isolated bidirectional DC-DC converter," *IET Power Electronics*, vol. 1, no. 4, pp. 507-517, 2008.
- [25] Bai, Hua, and Chris Mi., "Eliminate reactive power and increase system efficiency of isolated bidirectional dual-active-bridge DC-DC converters using novel dual-phase-shift control," *IEEE Transactions on Power Electronics*, vol. 23, no. 6, pp. 2905-291, 2008.

## BIOGRAPHIES OF AUTHORS



**M. Nagaiah** received his B. Tech degree in Electrical & Electronics Engineering from Nalanda Institute of Engineering and Technology, India in 2009 and M. Tech with Power System Engineering from R.V.R & J.C. College of Engineering Guntur, India in 2011. He is currently pursuing Ph. D in Acharya Nagarjuna University, Guntur, India. His Research interests are in the areas of Renewable Energy Sources and Artificial Intelligence.



**Dr. K. Chandra Sekhar** received his B. Tech degree in Electrical & Electronics Engineering from V.R. Siddhartha Engineering College, Vijayawada, India in 1991 and M. Tech with Electrical Machines & Industrial Drives from Regional Engineering College, Warangal, India in 1994. He Received PhD, degree from J.N.T.U, Hyderabad, India in 2008. He is having 24 years of teaching and Research experience. He is currently Professor & Head in the Department of Electrical & Electronics Engineering at R.V.R & J.C. College of Engineering Guntur, India. His Research interests are in the areas of Power Electronics, Industrial Drives, FACTS Controllers and Smart Grids.