

## Comparison between neural network and P&O method in optimizing MPPT control for photovoltaic cell

Ahmed G. Abdullah, Mothanna Sh. Aziz, Bashar A. Hamad

Department of Electrical Power Technology Engineering, Northern Technical University, Iraq

---

### Article Info

#### Article history:

Received May 7, 2019

Revised Apr 22, 2020

Accepted May 4, 2020

---

#### Keywords:

Boost chopper  
MPPT  
Neural network  
P&O  
PV system

---

### ABSTRACT

The demand for renewable energy has increased because it is considered a clean energy and does not result in any pollution or emission of toxic gases that negatively affect the environment and human health also requiring little maintenance, and emitting no noise, so it is necessary to develop this type of energy and increase its production capacity. In this research a design of maximum power point tracking (MPPT) control method using Neural Network (NN) for photovoltaic system is presented. First we design a standalone PV system linked to dc boost chopper with MPPT by perturbation and observation P&O technique, and then a design of MPPT by using ANN for the same system is presented. Comparative between two control methods are studied. The results explained in constant and adjustable weather settings such as irradiation and temperature. The results exposed that the proposed MPPT by ANN control can improve the PV array efficiency by reduce the oscillation around the MPP that accure in P&O method and so decreases the power losses. As well as decrease the the overshoot that accure in transient response, and hence improving the performance of the solar cell.

*Copyright © 2020 Institute of Advanced Engineering and Science.  
All rights reserved.*

---

### Corresponding Author:

Ahmed G. Abdullah,  
Department of Electrical Power Technology Engineering,  
Northern Technical University,  
Alminasa Road, Mosul, Iraq.  
Email: ahmed.g.alhealy@ntu.edu.iq

---

## 1. INTRODUCTION

Over the past few years significant progress has been made in development and research of renewable energy systems epitomised by marine wave energy, wind and solar power systems. The one of the best dependable renewable sources available today is solar energy. One of the obstacles to the use of solar systems is their high cost and low inefficiency. In order to improve the efficacy of the public PV array, a maximum power of the photovoltaic panel must be extracted using MPPT techniques.

The principle of operation of MPPT is built on the theory of transfer the maximum energy. A maximum power is obtained when the input-resistance seen by the source equal the source resistance [1-3]. Over the past two decades it has become the use of photovoltaic (PV) technology for electricity generation is increasing worldwide, PV cell has become well recognized in far and isolated area power supply, battery charging [4], where it can be the most economical choice, PV is also becoming more public in grid connected applications, interested by concerns about the influence of fossil fuel use to the improved greenhouse effect and other environmental issues. Many studies with several and comparative MPPT strategy based on different technique, price, and efficiency are mensioned in [5, 6].

Different MPPT methods have been presented in literature such as perturb and observe (P&O) [7-10], Hill Climbing (HC) [11, 12], incremental conductance (INC) [13, 14], comparative between P&O and incremental conductance [15, 16], fuzzy logic [17] comparative between P&O and fuzzy logic [18, 19], and neural network [20, 21]. The most known and commercially used methods is the (P&O).

Although, the problems of this technique are it cause oscillation around MPP lead to increase power losses. Additionally P&O system maybe fails to track the MPP when the sun insolation changes suddenly. Recently MPPT based intelligent control schemes have been introduced.

In this research, ANN method is applied to represent MPPT controller of PV array so as to decrease the oscillation and increase the efficiency. The inputs for the proposed NN are differ from the inputs for the P&O, where the voltage and current are used as inputs for P&O, while irradiation and temperature are used as inputs for the proposed ANN. Figure 1 show the block diagram of the suggested PV system. It consists of PV-model, Boost chopper and ANN MPPT controller.

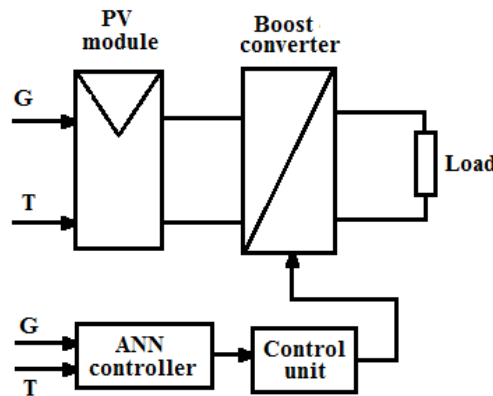

Figure 1. Block diagram of proposed PV array

**2. MATHEMATICAL MODELING OF THE PV CELL**

A solar cell can be represented by a current source  $I_{ph}$ , a reversed diode linked in parallel to it and internal resistances  $R_s$  and  $R_{sh}$ , [22] as represent in Figure 2.

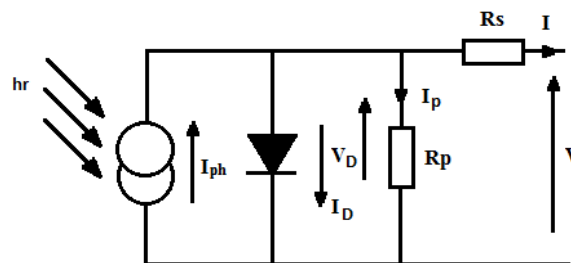

Figure 2. Mathematical modeling of a PV array

The basic equations that are defining the I-V characteristic of the PV cell are:

$$I = I_{ph} - I_D - I_p \tag{1}$$

$I_{ph}$  : photo current at (1000W/m<sup>2</sup> and 25°C).

$$I_{ph} = [I_{scr} + K_i(T_K - T_{ref})] \cdot \left(\frac{G}{1000}\right) \tag{2}$$

where:

- $K_i$  : is the temperature coefficient of cell
- $T_k$  and  $T_{ref}$  : are working temperature and reference temperature in kelvin respectively
- $G$  : irradiation (W/m<sup>2</sup>),  $I_p$  : Current of  $R_p$
- $I_D$  : Diode Current, it is given by:

$$I_D = I_o \left[ \exp\left(\frac{q V_D}{A K T}\right) - 1 \right]$$

$$I_D = I_o \left[ \exp\left(\frac{q(V + R_S I)}{A K T}\right) - 1 \right]$$
(3)

where:

- q : charge=1.6×10<sup>-19</sup>C and
- K : boltzman constant =1.38 ×10<sup>-23</sup>J/K
- T :PV temperature in(K°).
- I<sub>o</sub> : saturation current.

$$I_o = I_{rs} \left[ \frac{T}{T_r} \right]^3 \exp \left[ \left( \frac{q E_{go}}{A K} \right) \left( \frac{1}{T_r} - \frac{1}{T} \right) \right]$$
(4)

I<sub>rs</sub>: inverse sat current.

$$I_{rs} = \frac{I_{scr}}{\exp \left[ \frac{q V_{oc}}{N_s A K T} \right] - 1}$$
(5)

where:

- A : is the ideality factor.
  - E<sub>go</sub> : is the semiconductor bandgap energy =1.1eV for Si.
- Substituting these equations in (1) yields:

$$I = N_p I_{ph} - N_p I_o \left[ \exp\left(\frac{q(V + R_S I)}{N_s A K T}\right) - 1 \right] - \frac{V + R_S I}{R_p}$$
(6)

where: N<sub>s</sub> and N<sub>p</sub> are series and parallel connections number of cell.

Using the above equations and the parameters mentioned in Table 1 the module is simulated using Matlab Simulink, the V-I characteristics of the PV model is shown in Figure 3 and the power Vs voltage characteristics is shown in Figure 4.

Table 1. Parameters of PV panel

Variable	value
Maximum power	200w
Open circuit voltage	32.9V
Short circuit current	8.21A
Temperature coeffecent	3.8×10 <sup>-3</sup> A/C°

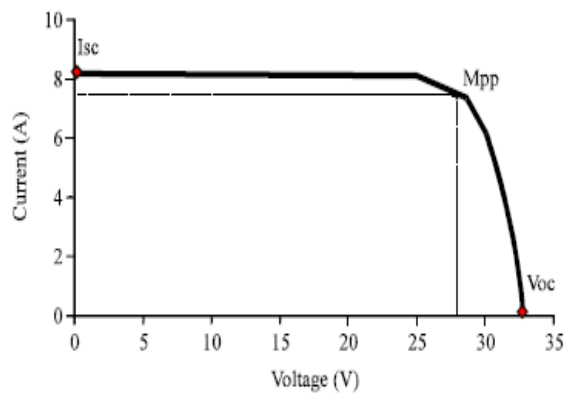

Figure 3. V-I characteristics of PV panel

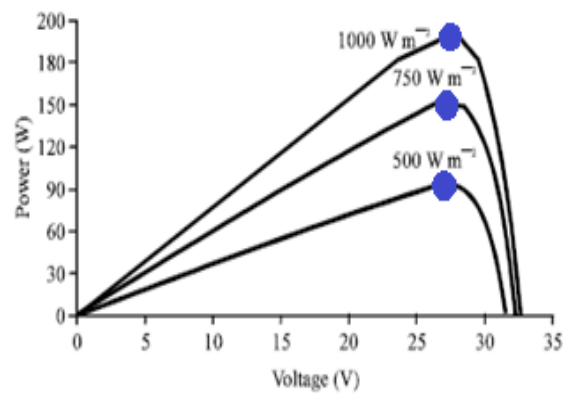

Figure 4. P-V characteristics of PV panel

### 3. MODELLING OF BOOST CONVERTER

The electrical circuit of dc boost chopper is displayed in Figure 5. The control methodology in this converter apply by control the duty-cycle (D) of the power transistor, this lead to changing the load voltage [23, 24]. When the power transistor is turn on the coil store the current and the voltage of coil is equal to the source voltage, when switch is turn off the energy storage in the coil as well as the source voltage is converted to the load through the diode this operation lead to boost the load voltage according to law:

$$\frac{V_o}{V_{in}} = \frac{1}{1 - D} \quad (7)$$

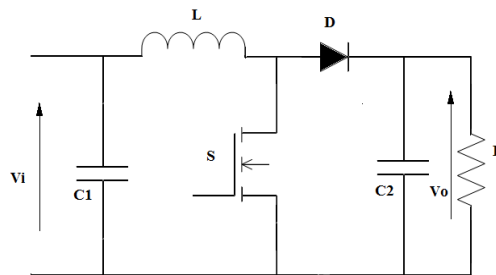

Figure 5. DC chopper

### 4. MAXIMUM POWER POINT TRACKING (MPPT)

As was earlier clarified, MPPT procedures are required in photovoltaic uses, in fact that the maximum power of PV cell variations with Intensity of sun radiation and temperature so that, the use of MPPT systems is exceptionally essential to attain the greatest power from a sun oriented array [25]. The simple scheme of MPPT control is to discover voltage and current reference at maximum power under various states of sun illumination and temperature by altering the estimation of load R. Figure 6 demonstrates the (I-V) and (P-V) curves. Operational point (OPR<sub>1</sub>) is the greatest power point (MPP) esteem in the condition irradiation (G<sub>1</sub>), temperature (T<sub>1</sub>) and load (R<sub>1</sub>). If the illumination vary from (G<sub>1</sub> to G<sub>2</sub>) and temperature vary from T<sub>1</sub> to T<sub>2</sub>, the I-V bend move from the bend (G<sub>1</sub>, T<sub>1</sub>) to the bend (G<sub>2</sub>, T<sub>2</sub>). Load state must be varied from R<sub>1</sub> to R<sub>2</sub> to obtain MPP at (OPR<sub>2</sub>) [25]. Many algorithms like (P&O), (INC), intelligent technique like (FL) and (NN) can be employed to accomplish the automatic tracing. We generally focus on the P&O and NN techniques.

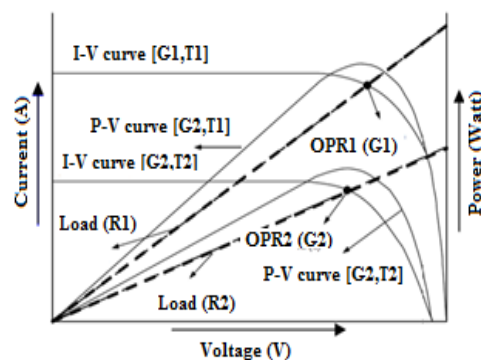

Figure 6. MPPT curve

### 5. MPPT BY PERTURB & OBSERVE (P&O) METHOD

The important part of a PV arrangement is to Find the maximum power (MPP) of solar cell, because of nonlinear features and small efficiency of photovoltaic groups. The P&O method is one of the best regularly used MPPT approaches for its easiness and simplicity of execution [7, 8]. In this technique, the voltage set is a slight disturbed (rise or fall) and the real rate of the power P(k) compared to the prior attained value P(k-1). The flowchart of the P & O mode is displayed in Figure 7.

The P&O technique has slowness dynamic reply, the minute there is a slight rise in the amount and small sample ratio is in use. small increase is needed to reduce the steady state error where the P&O cause oscillation around the MPP. The communal difficult in P&O technique is the arrangement voltage disturbed each MPPT duration. Once the MPP is obtained, the output energy fluctuates around the wave, leading to a loss of power in the photoelectric system. This is particularly accurate in fixed or slow-changing atmospheres.

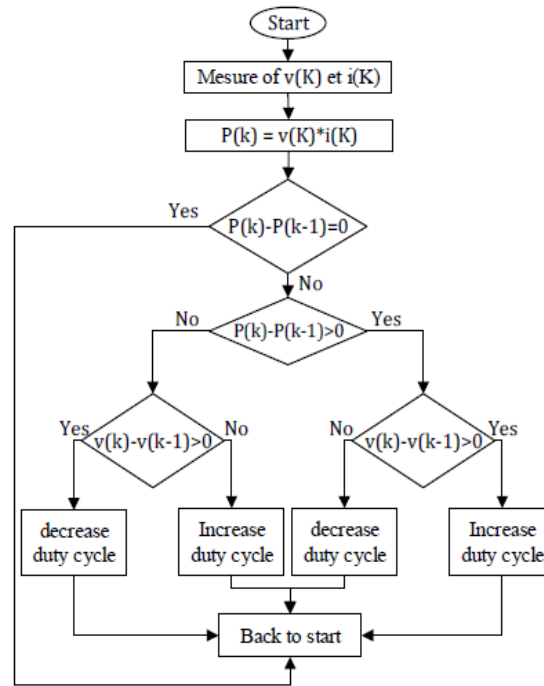

Figure 7. Classical P&O scheme flow chart

## 6. ARTIFICIAL NEURAL NETWORKS

Artificial Neural Network (ANN) are usually recognized as a tools proposing an unusual way to resolve multifarious problems. ANN is an exact model that attempts to pretend to build and function organic neural networks. ANN is a data treating scheme. It contains a number of simple exceedingly consistent processors (elements) recognized as neurons. These neurons are connected to each other by a huge number of weights links to be a network. Such networks have extraordinary example acknowledgment and learning capacities. Late uses of ANN have demonstrated that they take critical potential in conquering the hard duties of data taking care of and clarification. Multilayered feedforward (backpropagation BPN) ANN is the best generally held sort utilized by several requests. It involves an input layer, one or further hidden layers, and a target layer [1, 20].

## 7. MPPT BY USING PROPOSED NEURAL NETWORK

In order to use ANN as MPPT controller for PV system, we follow the following steps:

- Step 1: Choosing the structure of the proposed NN: in this research the proposed network chosen have three layers, two variables (irradiance  $G$  and temperature  $T$ ) are used as inputs instead of voltage and current that used in P& O method, ten neurons in hidden layer with log sigmoid activation function and the (Modulation signal  $M$ ) is used as output for NN. The proposed ANN architecture is shown in Figure 8.
- Step 2: Training the neural network: To train the neural network it is required to obtain example pattern as input and target. PV system with P&O is designed and simulated in order to obtain training data to train the NN as well as to compare the results. A large number of example pattern are taken for different conditions of temperature and illumination from the simulated system under P&O controller. off line training by error back propagation method using (Levinberg Marquardt LM) way is used to train the ANN in matlab by NNTOOL command, since this algorithm is use to solve non-linear problems as well as more robust than other technique.

- Step 3: Simulate the proposed NN: after training the NN and obtained weights, this network is simulated using Matlab simulink and joined to the PV and Boost chooper to operate as MPPT controller. The algorithm of the MPPT by proposed NN is represented in Figure 9.

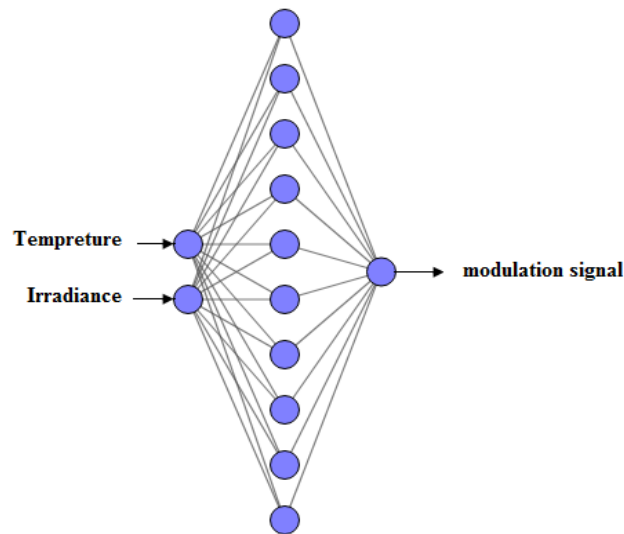

Figure 8. Proposed ANN architecture

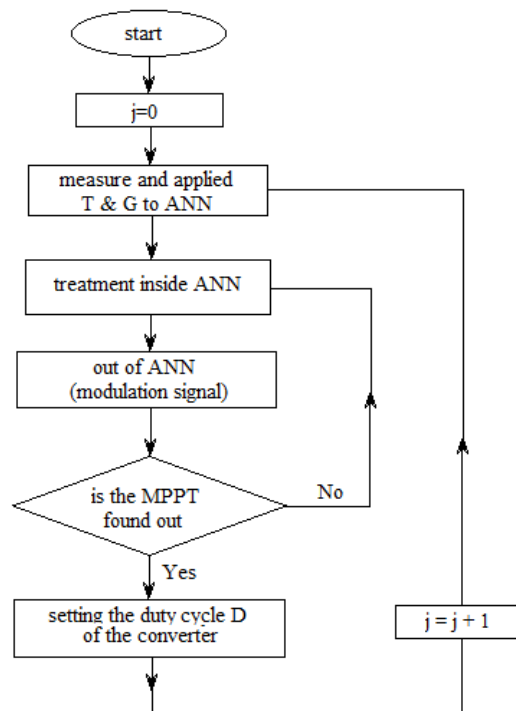

Figure 9. MPPT by proposed NN

## 8. SIMULATION RESULTS

To validate the study stated in earlier units, a standalone PV scheme joined to a dc boost converter and simulated using MATLAB-SIMULINK. Two MPPT strategies are designed and applied to the PV simulated system, the first one is the P&O algorithm, the simulated circuit is presented in Figure 10. The second model is PV system MPPT by using Neural Network display in Figure 11.

In order to estimate the act of the P&O and ANN MPPTs, two cases of inputs to the simulated models in Figure 10 and Figure 11 are applied:

- Constant temperature (25°C) and variable irradiation suddenly change at (300, 500, 1000, 800 W/m<sup>2</sup>)

Figure 12(a) show the results of PV structure MPPT by ANN controller and Figure 12(b) show the results of PV structure MPPT by P&O controller.

- Constant irradiation (1000 W/m<sup>2</sup>) and variable temperature suddenly change at (25, 40, 0, 50 °C).

Figure 13(a) show the results of PV system with ANN MPPT controller and Figure 13(b) show the results of PV structure with MPPT by P&O controller.

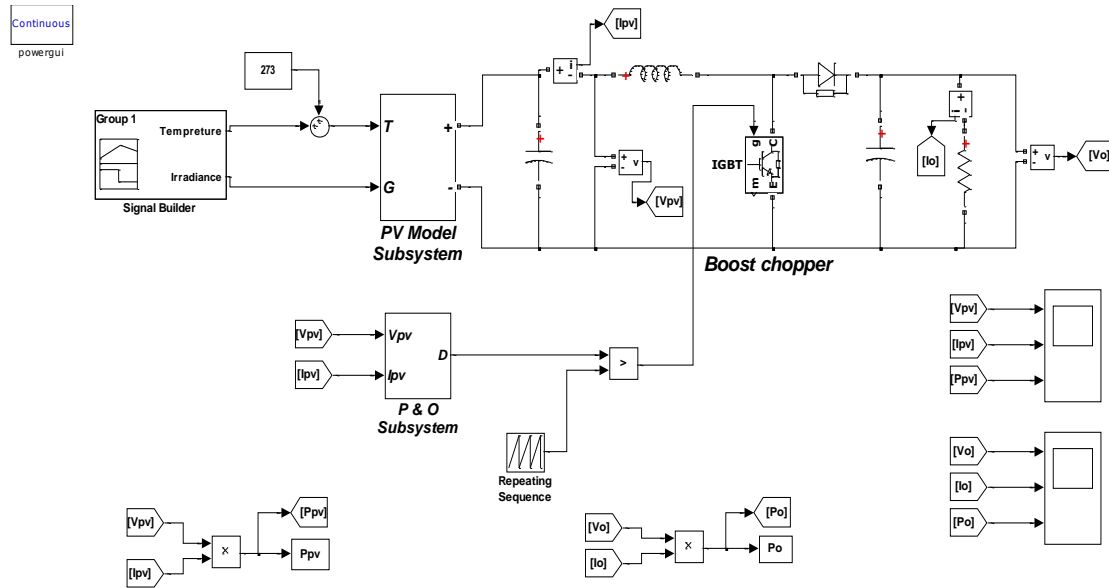

Figure 10. PV simulated circuit MPPT by P&O algorithm

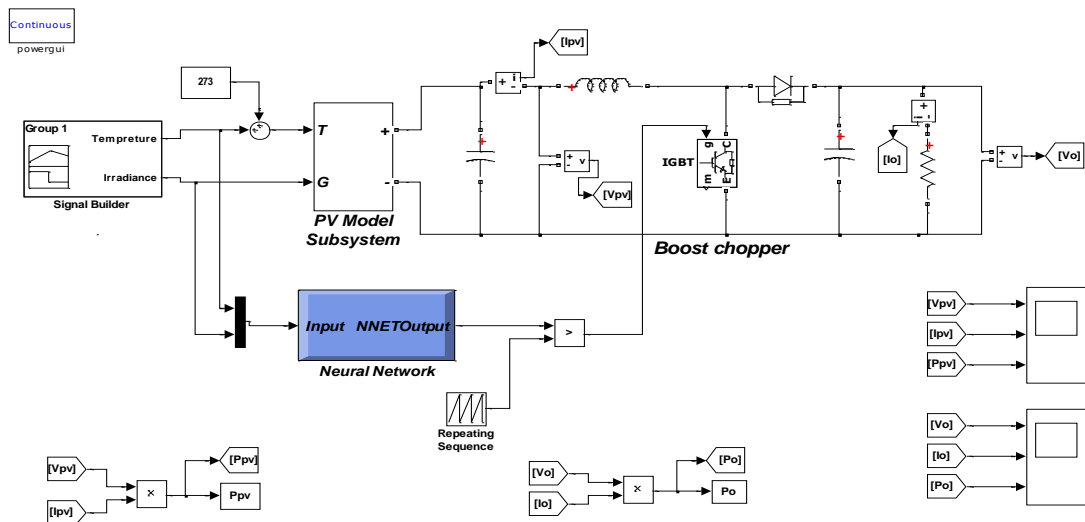

Figure 11. PV simulated circuit MPPT by NN algorithm

As shows in Figure 12 and Figure 13, ANN scheme can give fast track the MPP under steady state and very small peak overshoot is noted when sudden varying in irradiation or temperature happen, the P&O is also track MPP in steady state but large peak overshoot is noted when sudden change in irradiation or

temperature accrued. Also, ANN has very small oscillation around MPP, while very high oscillation is noted in P&O method, this is increase in power losses. These results have proved that the MPPT by using the proposed NN best and more robust than the MPPT by P&O method.

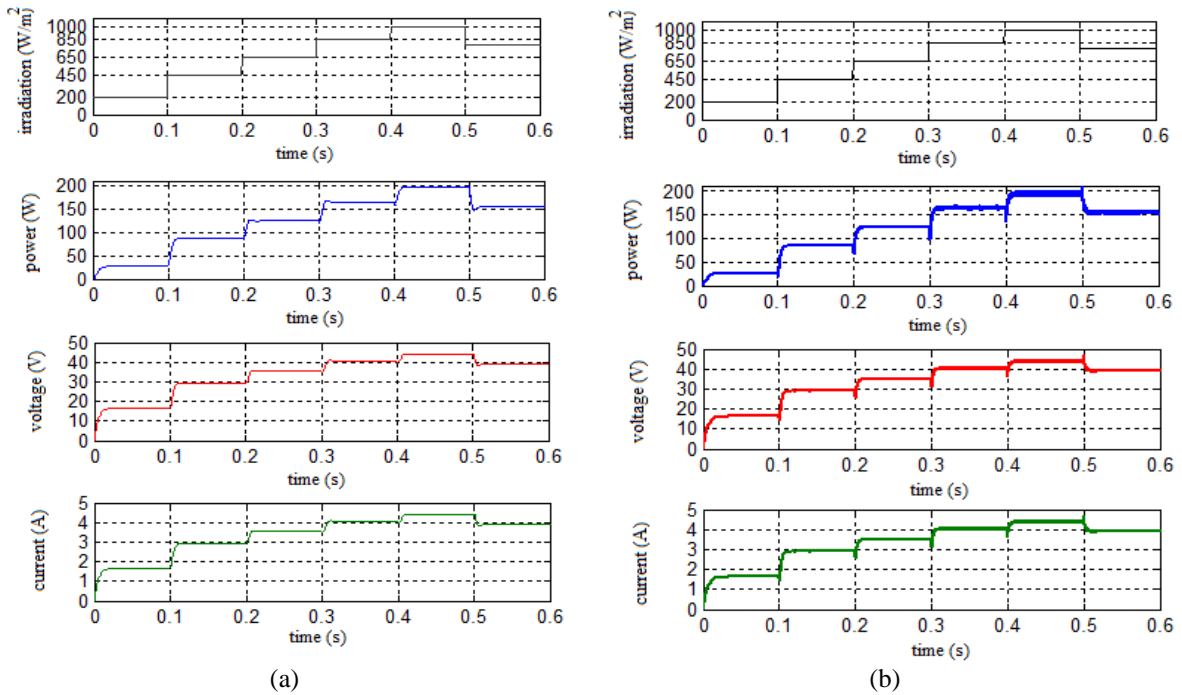

Figure 12. Load current, load voltage and load power for the PV system under suddenly change of irradiation and constant temperature of  $25^\circ\text{C}$  when (a) MPPT by using ANN, (b) MPPT by using P&O

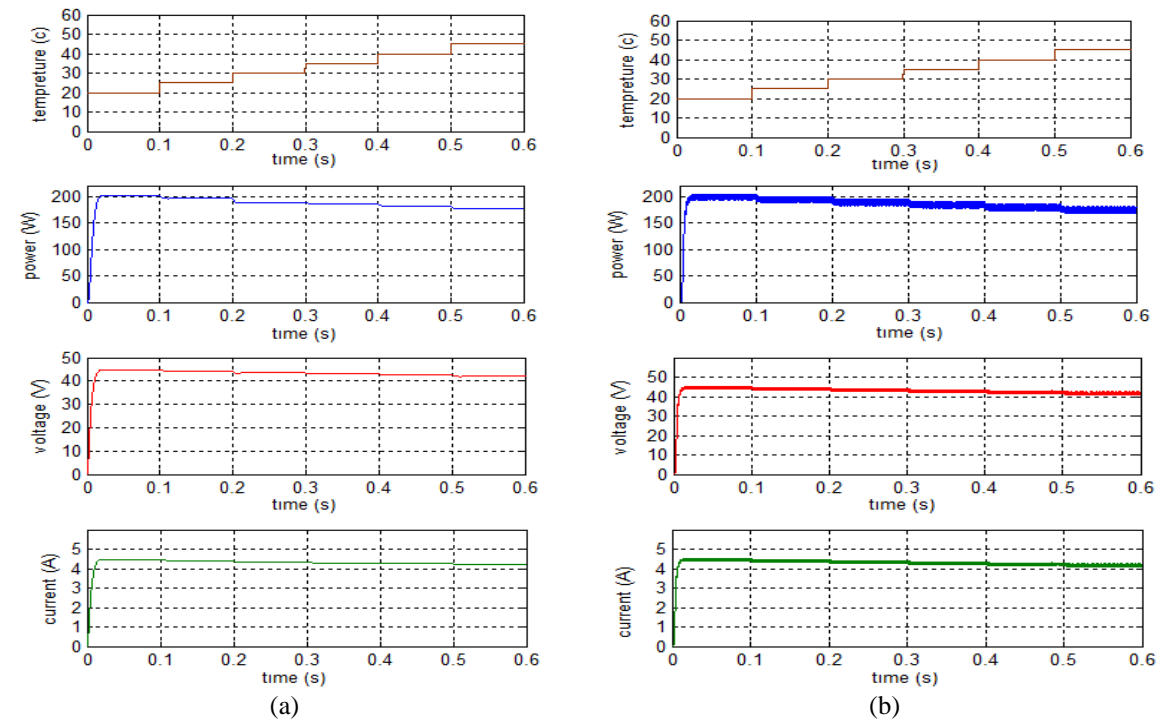

Figure 13. Load current, load voltage and load power for the PV system under suddenly change of temperature and constant irradiation of  $1000 \text{ W/m}^2$  when (a) MPPT by using ANN, (b) MPPT by using P&O



## 9. CONCLUSION

This paper discusses a design of MPPT control for PV array using ANN at any atmospheric conditions and comparing the results with classical MPPT way. Two model of photovoltaic cells with two MPPT strategy are designed and simulated, the first one is PV system MPPT by classical Perturbation and Observation (P&O) method, and the second is PV system MPPT by Artificial Neural Network (ANN). The simulation results of the two MPPT controllers are compared by testing the PV systems under the same atmospheric settings. The results exposed that the proposed ANN control can improve the efficiency of the PV array by reducing the oscillation around the MPP and therefore decrease the power losses that noted in PV with P& O way, as well as the transient response of ANN is better than P&O controller when sudden change of irradiation or temperature occur.

## REFERENCES

- [1] M. T. Makhoulfi, M. S. Khireddine, Y. Abdessemed, and A. Boutarfa, "Tracking Power Photovoltaic System using Artificial Neural Network Control Strategy," *International Journal of Intelligent Systems and Applications*, vol. 6, no. 12, pp. 17-26, 2014.
- [2] J. Jiang, T. Huang Y. Hsiao and C. Chen, "Maximum Power Tracking for Photovoltaic Power System," *Tamkang Journal of Science and Engineering*, vol. 8, no. 2, pp. 147-153, 2002.
- [3] S. D. Stallon, K. V. Kumar, S. S. Kumar, and J. Baby, "Simulation of High Step-Up DC-DC Converter for Photovoltaic Module Application using MATLAB/SIMULINK," *International Journal of Intelligent Systems and Applications*, vol. 5, no. 7, pp. 72-82, 2013.
- [4] Z. M. Abdullallah, O. T. Mahmood, and A. M. T. I. Al-naib, "Photovoltaic Battery Charging System Based on PIC16F877A Microcontroller," *International Journal of Engineering and Advanced Technology (IJEAT)*, vol. 3, no. 4, pp. 27-31, 2014.
- [5] R. De Keyser, J. Bonilla, I. S. Member, C. Ionescu, and J. Alarcon, "A comparative study of several control techniques applied to a boost converter," *IEEE 10th Int Conf on Optimisation of Electrical and Electronic Equipment OPTIM*, Brasov Romania, pp. 71-78, 2006.
- [6] M. Hlaili and H. Mechergui, "Comparison of Different MPPT Algorithms with a Proposed One Using a Power Estimator for Grid Connected PV Systems," *International Journal of Photoenergy*, vol. 2016, pp. 1-10, 2016.
- [7] N. Femia, G. Petrone, G. Spagnuolo, and M. Vitelli, "Optimization of perturb and observe maximum power point tracking method," *IEEE Transactions on Power Electronics*, vol. 20, no. 4, pp. 963-973, 2005.
- [8] T. Chaitanya, Ch. Saibabu, and J. S. Kumari, "Modeling and Simulation of PV Array and its Performance Enhancement Using MPPT (P&O) Technique," *International Journal of Computer Science and Communication Networks*, vol. 1, no. 1, pp. 9-16, 2011.
- [9] K. Saidi, M. Maamoun, and M. Bounekhla, "A new high performance variable step size perturb-and-observe MPPT algorithm for photovoltaic system," *International Journal of Power Electronics and Drive System (IJPEDS)*, vol. 10, no. 3, pp. 1662-1674, 2019.
- [10] S. K. Kollimalla, and M. K. Mishra, "A Novel Adaptive P&O MPPT Algorithm Considering Sudden Changes in the Irradiance," *IEEE Transactions on Energy Conversions*, pp. 1-9, 2014.
- [11] M. I. Bahari, P. Tarassodi, Y. M. Naeini, A. K. Khalilabad, and P. Shirazi, "Modeling and Simulation of Hill Climbing MPPT Algorithm for PhotoVoltaic Application," *International Symposium on Power Electronics, Electrical Drives, Automation and Motion*, pp. 1041-1044, 2016.
- [12] H. A. Sujono, R. Sulistyowati, A. Safi, and C. W. Priananda, "Photovoltaic Farm With Maximum Power Point Traker Using Hill Climbing Algorithm," *ARPN Journal of Engineering and Applied Sciences*, vol. 13, no. 13, pp. 4167-4172, 2018.
- [13] R. I. Putri, S. Wibowo, and M. Rifa, "Maximum power point tracking for photovoltaic using incremental conductance method," *Energy Procedia*, vol. 68, pp. 22-30, 2015.
- [14] N. E. Zakzouk, M. A. Elsaharty, A. K. Abdelsalam, A. A. Helal, and B. W. Williams, "Improved performance low-cost incremental conductance PV MPPT technique," *IET Renewable Power Generation*, vol. 10, no. 4, pp. 561-574, 2016.
- [15] S. Khadidja, M. Mountassar, and B. M'hamed "Comparative study of Incremental Conductance and Perturb & Observe MPPT Methods for Photovoltaic System," *2017 International Conference on Green Energy Conversion Systems (GECS)*, Hammamet, pp. 1-6, 2017.
- [16] A. A. Abdulrazzaq and A. H. Ali, "Efficiency Performances of Two MPPT Algorithms for PV System With Different Solar Panels Irradiances," *International Journal of Power Electronics and Drive System (IJPEDS)*, vol. 9, no. 4, pp. 1755-1764, 2018.
- [17] A. S. Samosir, H. Gusmedi, S. Purwiyanti, and E. Komalasari, "Modeling and Simulation of Fuzzy Logic based Maximum Power Point Tracking ( MPPT ) for PV Application," *International Journal of Electrical and Computer Engineering (IJECE)*, vol. 8, no. 3, pp. 1315-1323, 2018.
- [18] H. Bouchcha, A. Bouzid, K. Nabti, and H. Benalla, "Comparison of perturb & observe and fuzzy logic in maximum power point tracker for PV systems," *Energy Procedia*, vol. 50, pp. 677-684, 2014.
- [19] H. Otmame, M. Youssef, B. Mokhtar, and A. Info, "Comparative analysis of cascaded Fuzzy-PI controllers based-MPPT and perturb and observe MPPT in a grid-connected PV system operating under different weather and loading conditions," *International Journal of Power Electronics and Drive System (IJPEDS)*, vol. 10, no. 4, pp. 1986-1994, 2019.

- 
- [20] R. M. Essefi, M. Souissi, and H. H. Abdallah, "Maximum Power Point Tracking Control Using Neural Networks for Stand-Alone Photovoltaic Systems," *International Journal of Modern Nonlinear Theory and Application*, vol. 3, no. 3, pp. 53-65, 2014.
- [21] F. Saadaoui, K. Mammam, and A. Hazzab, "Modeling of photovoltaic system with maximum power point tracking control by neural networks," *International Journal of Power Electronics and Drive System (IJPEDS)*, vol. 10, no. 3, pp. 1575-1591, 2019.
- [22] H. Yatimi and E. Aroudam, "Mathematical Modeling and Simulation of Photovoltaic Power Source using Matlab / Simulink," *International Journal of Innovation and Applied Studies*, vol. 16, no. 2, pp. 322-330, 2016.
- [23] A. Pradhan and B. Panda, "A Simplified Design and Modeling of Boost Converter for Photovoltaic Sytem," *International Journal of Electrical and Computer Engineering (IJECE)*, vol. 8, no. 1, pp. 141-149, 2018.
- [24] R. Palanisamy, K. Vijayakumar, V. Venkatachalam, R. M. Narayanan, D. Saravanakumar, and K. Saravanan, "Simulation of various DC-DC converters for photovoltaic system," *International Journal of Electrical and Computer Engineering (IJECE)*, vol. 9, no. 2, pp. 917-925, 2019.
- [25] S. Aji, D. Ajiatmo, I. Robandi, and H. Suryatmojo, "Mppt Based On Fuzzy Logic Controller (FLC) For Photovoltaic (PV) System In Solar Car," *Mechatronics, Electrical Power, and Vehicular Technology*, vol. 4, no. 2, pp. 127-134, 2013.