

## BLDC motor driven electric skateboard using SVPWM

R. Palanisamy<sup>1</sup>, Th. Ankit Singh<sup>2</sup>, Anamika Ranjan<sup>3</sup>, Jatin Singh<sup>4</sup>

<sup>1</sup>Department of EEE, SRM Institute of Science and Technology, Chennai, India

<sup>2,3,4</sup>UG Research Scholar, Department of EEE, SRM Institute of Science and Technology, Chennai, India

---

### Article Info

#### Article history:

Received Apr 5, 2019

Revised Sep 16, 2019

Accepted Sep 27, 2019

---

#### Keywords:

555 timer

BLDC motor

Electric skateboard

Space vector pulse width

modulation

---

### ABSTRACT

Several problems are faced by today's generation. One of them is the increase in pollution in our everyday life. Each of us can play a part in reducing this by using some environmentally friendly method such as cycles which requires mechanical force. Another way to accomplish this is by using electricity to produce this mechanical force i.e. electric motor. In this paper BLDC motor driven electric skateboard is designed with mathematical calculation, verified with simulation and developed as a experimental setup.

Copyright © 2020 Institute of Advanced Engineering and Science.  
All rights reserved.

---

### Corresponding Author:

R. Palanisamy,

Department of Electrical and Electronics Engineering,

SRM Institute of Science and Technology, Chennai, India.

Email: krspalani@gmail.com

---

## 1. INTRODUCTION

Pulse Width Modulation is a technique of modulation of the digital pulses. This method is used for controlling the power supply to any device [1, 2]. This is achieved by changing the sweep of the pulses. The ON and OFF time of the circuit is modified accordingly [3]. The on and off time control the output voltage and thus help in controlling the connected device. This method of output voltage control is used being used to change the speed of the DC motor for this project [4].

The time period for which a device conducts is called as the ON time of the device. Similarly, the time period when the device does not conduct is called the OFF period [5]. The ratio of this on time to the total time period (on time+ off time) is called as the Duty Ratio. In our project, we attempt to change this duty ratio of the PWM circuit and feed it to the motor [6]. The change in duty cycle operates the turning on and off of the motor. This, thereby increases and decreases the speed of the motor. The switching characteristics are performed with the help of a potentiometer whose resistance value is changed [7]. With increase in resistance, the speed decreases and with decrease in resistance, the speed increases. This potentiometer acts as a throttle for the electric skateboard [8].

Space vector modulation is a mathematical procedure which is applied for control of the pulse width modulation. It is opted for the generation of alternating current waveform to run the motors at variable speeds [9, 10]. There are changes of Space Vector Modulation that affects the computational requirements. This acts as an inverter circuit. The output from this is provided to a BLDC motor since a DC motor will not run on an inverter output [11, 12]. However, the PWM technique is a preferred speed control techniques for a DC motor. A high frequency chopper signal with specific duty cycle is increased by switch signals [13]. When the power supply is on, the DC motor starts gaining speed and if we turn off the power supply before it reaches at rated speed, and its speed decreases. In fast succession of switch on and switch off steps, the motor speed is modulated. For this, paper we use PWM methodology modified to SVPWM which runs the motor [14].

## 2. PULSE WIDTH MODULATION

Pulse width modulation speed management is a result of driving the motor with a continuous series of “ON-OFF” pulses. By altering the duty cycle, the fraction of the time during which the output voltage is “ON” to once it is “OFF” changes. During the alteration of the pulses, the frequency is kept constant [15-17]. The Figure 1 show the pulse width modulation technique.

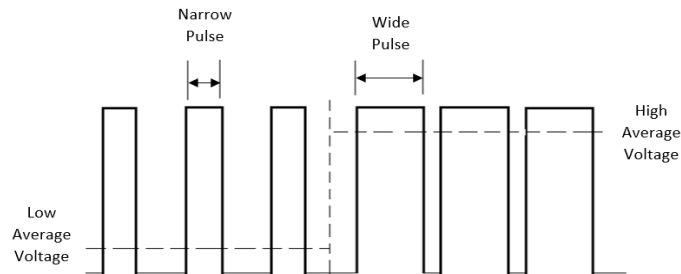

Figure 1. Pulse Width Modulation

This value of ON and OFF time can be manipulated as per the requirements [18, 19]. PWM is done by using electronic switches (transistors) which gives the following advantages:

- The power loss in the transistor is very low because the switching sequence in transistor means it is either fully “ON” or fully “OFF”. The transistor does not have an intermediate state.
- Voltage amplitude of the motor is maintained at a constant level so that the motor will always be at full strength. The result is that the motor is moving much slower without stalling [20].
- The 555 timer is an IC which is used for timers, pulse generation, and oscillations. They are used to assist with time delays, as an oscillator, and even as a flip-flop element [21, 22].

## 3. SPACE WIDTH PULSE WIDTH MODULATION (SVPWM)

Space vector PWM is an algorithm which is used to control the pulse output of the circuit. A three-phase inverter circuit converts the DC supply, with the help of a combination of switches, to give 3 output lines which is then connected to a motor [23-25]. The switches are controlled in a way where at any given time the two switches on the same leg are not turned on. This would result in a short circuit. This demand can be fulfilled by the complementary working of the switches on the same leg. It includes 6 non-zero switching vectors and 2 zero vectors [26-28].

To implement SVPWM, a reference signal is considered whose frequency is assumed to be  $f_s$ . This signal is generated from three separate phase references using the  $\alpha\beta\gamma$  transformation. The vector is then processed with the help of a combination of the two neighbouring active vectors and one or both of the 0 vectors. The space vector modulation diagram can see in Figure 2 and Table 1 show representation of switching state vectors of SVPWM.

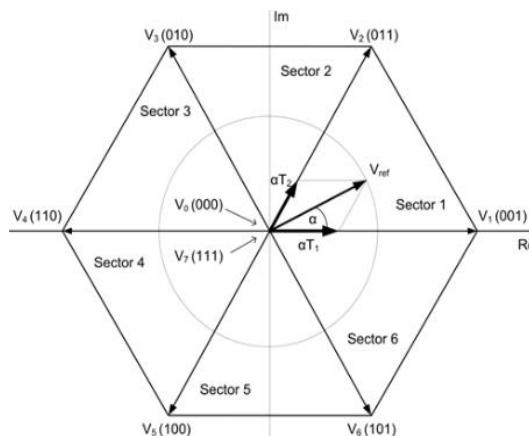

Figure 2. Space Vector modulation diagram

Table 1. Representation of switching state vectors of SVPWM

| Vector  | A+  | B+  | C+  | A-  | B-  | C-  | Vab  | Vbc  | Vca  |
|---------|-----|-----|-----|-----|-----|-----|------|------|------|
| V0(000) | OFF | OFF | OFF | ON  | ON  | ON  | 0    | 0    | 0    |
| V1(100) | ON  | OFF | OFF | OFF | ON  | ON  | Vdc  | 0    | -Vdc |
| V2(110) | ON  | ON  | OFF | OFF | OFF | ON  | 0    | Vdc  | -Vdc |
| V3(010) | OFF | ON  | OFF | ON  | OFF | ON  | -Vdc | Vdc  | 0    |
| V4(011) | OFF | ON  | ON  | ON  | OFF | OFF | -Vdc | 0    | Vdc  |
| V5(001) | OFF | OFF | ON  | ON  | ON  | OFF | 0    | -Vdc | Vdc  |
| V6(101) | ON  | OFF | ON  | OFF | ON  | OFF | Vdc  | -Vdc | 0    |
| V7(111) | ON  | ON  | ON  | OFF | OFF | OFF | 0    | 0    | 0    |

**4. PROPOSED SYSTEM**

A 24 volt DC battery supplies power to the SVPWM speed control circuit. The speed controller circuit receives input resistance from the throttle which modulates the pulse width. The output of this Pulse Width Modulation circuit is fed to a BLDC motor. The voltage changes caused by the PWM circuit in turn alters the speed of the motor. The change in level of voltage is decided by a user or rider through throttle connected to the circuit. Figure 3 show the proposed system.

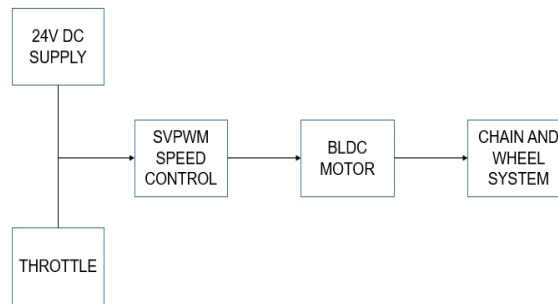

Figure 3. Proposed system

The level of voltage is directly proportional to the speed of the motor, i.e., with increase in the voltage, the motor speed increases and similarly, with decrease in voltage, the motor slows down. The dc motor is connected to the chain and wheel assembly through a sprocket chain system and a subsequent mechanical braking system to stop the motor all together. 555 timer based PWM circuit for DC motor can see in Figure 4.

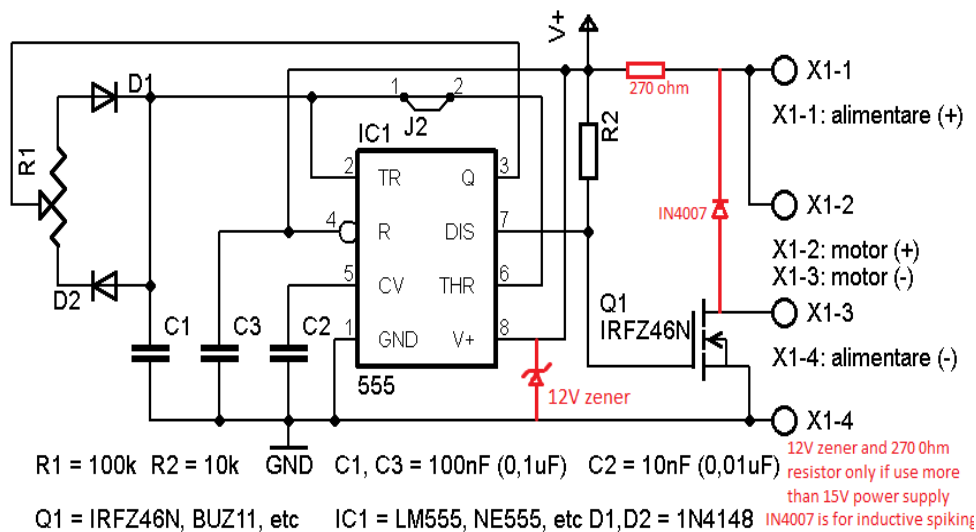

Figure 4. 555 timer based PWM circuit for DC motor

The control of this on and off period causes change in the waveform's width. If period of being on is greater than period of being off the speed increases and vice versa. There are two methods to change the on and the off period. One is by changing the value of capacitance of the capacitor i.e. if we increase the capacitance, it will take more time to charge the capacitor. And the off period will increase and if we decrease the capacitance. Another method is by using a resistor in series with the capacitor.

If the resistance is high during charging then it will take more time to charge and so higher off time and if it's less during charging then it will take less time to charge so less off time. Similarly, if the during discharging if resistance is more then on time will be more and if it's less then lesser on time. Manipulating this method, we can change the on and off time so in turn changing the speed accordingly. In the circuit, we have utilized a potentiometer to apply the second method. So during the charging time, the current passes through D1 and during the discharge period, it is from D2. Turning the potentiometer, we can change the resistance during charging and discharging therefor controlling the speed. Additional two more components are used which are 12V Zener diode and 270ohm resistor. 12V Zener diode is used to protect the IC from high voltage.

#### 4. MATHEMATICAL MODELLING AND TRUCKS DESIGN

##### 4.1. Friction calculation

Taking total weigh as 80kg

M is static friction coefficient

G is gravitational acceleration

$$\begin{aligned} F &= m \cdot g \cdot m \\ &= 80 \cdot 9.8 \cdot 0.6 \\ &= 470.4 \text{N} \end{aligned}$$

Now for each wheel

$$F/4 = 118 \text{(approx.)}$$

So, torque will be

$$T = 118 \cdot (\text{radius of wheel in meter}) = 118 \cdot 0.1016 = 12 \text{Nm}$$

From this we can conclude that we need more than 12Nm torque to move the object. Also gear ratio will also determine how much torque will be given out from a particular motor. So, taking care of the radius of the wheel we will take a sprocket with radius less than, the wheel radius, therefore assuming a 33T sprocket having radius 0.066m. Having 11T on motor. So, gear ratio will be: GR (gear ratio) = 33T/11T = 3. We know that motor torque should such that wheel torque is more than 12Nm therefore, Torque on wheel > (3 \* motor torque). This concludes the need of a motor with stalling torque greater than 4Nm i.e. either 5Nm or more. After some search for motors of required specification, a 250w 24V dc motor with 5Nm stalling torque was decided to be implemented.

##### 4.2. Battery

Two 1500mAh 3S 30C (11.1V) Lithium Polymer Battery Pack is attached in series to supply 22.2Volt.

SPECIFICATIONS

3s; 30c; 1500mAh

Trucks are the mechanical structure in skateboards which gives them directions. Channel trucks design is used. These metal parts are made by mounting an axle to the bottom piece of the truck. They are mounted to the deck of the skateboard at a predetermined angle, (here, 45°). When the board is inclined, the axles will converge the wheels in the direction of the respective turn. With this mechanism in action, the skateboard axles will angle itself such that the skateboard will not overturn and will stay parallel to the ground. Springs are attached between the hanger and the axle housing provide resistance against the lean of the rider during turning. Springs return the deck to initial state after a turn has been performed.

#### 5. RESULTS AND DISCUSSION

The Figure 5 shows change in voltage with change in duration of the time, the speed of the motor changes. As soon as the off period starts, the speed of the motor starts decreasing till the switch turns on again and the on period begins. The Simulation Circuit of the proposed system is shown in Figure 6.

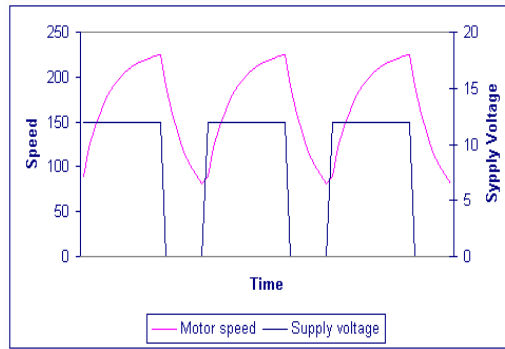

Figure 5. PWM with change in Voltage

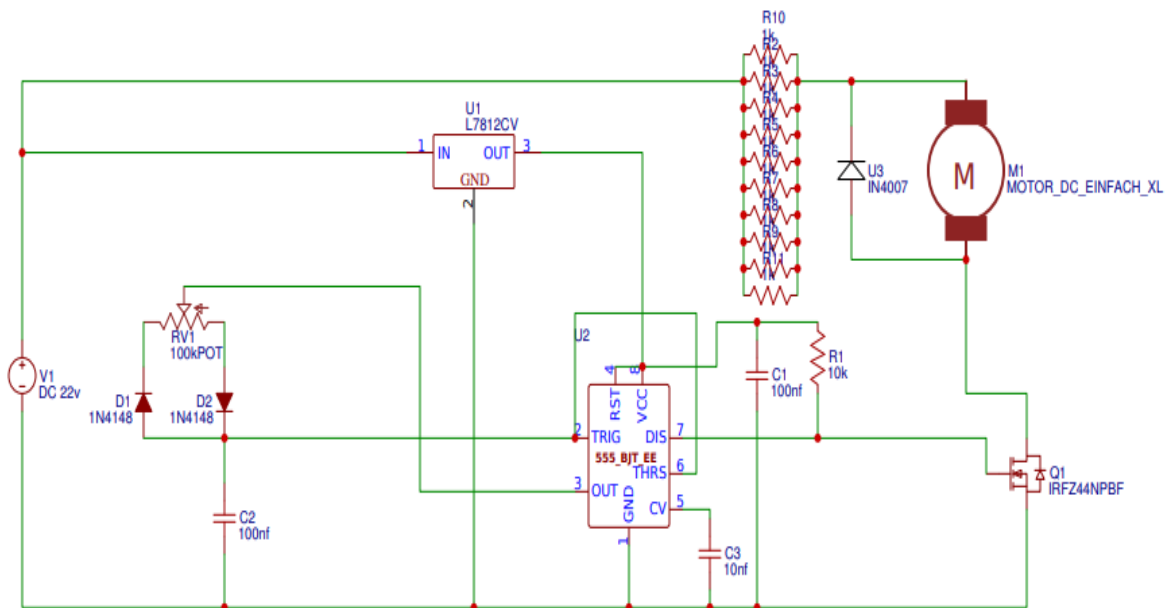

Figure 6. Simulation Circuit of the proposed system

**6. HARDWARE RESULTS AND DISCUSSION**

The Figure 7 shows the Step by Step procedure for hardware implementation, which is clearly represented from (a-f). The Figure 8 shows the output voltage of Space Vector Pulse Width Modulation and Output voltage graph with respect to potentiometer is shown in Figure 9.

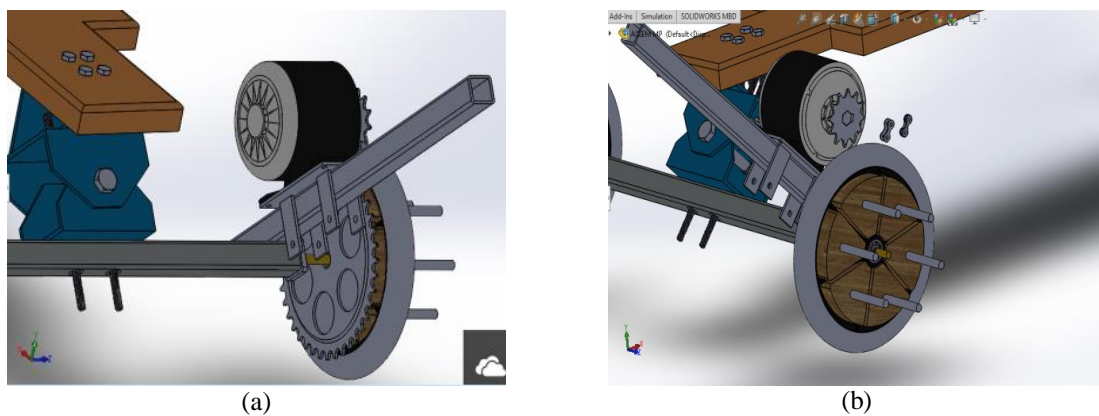

Figure 7. Step by Step procedure for hardware implementation (continue)

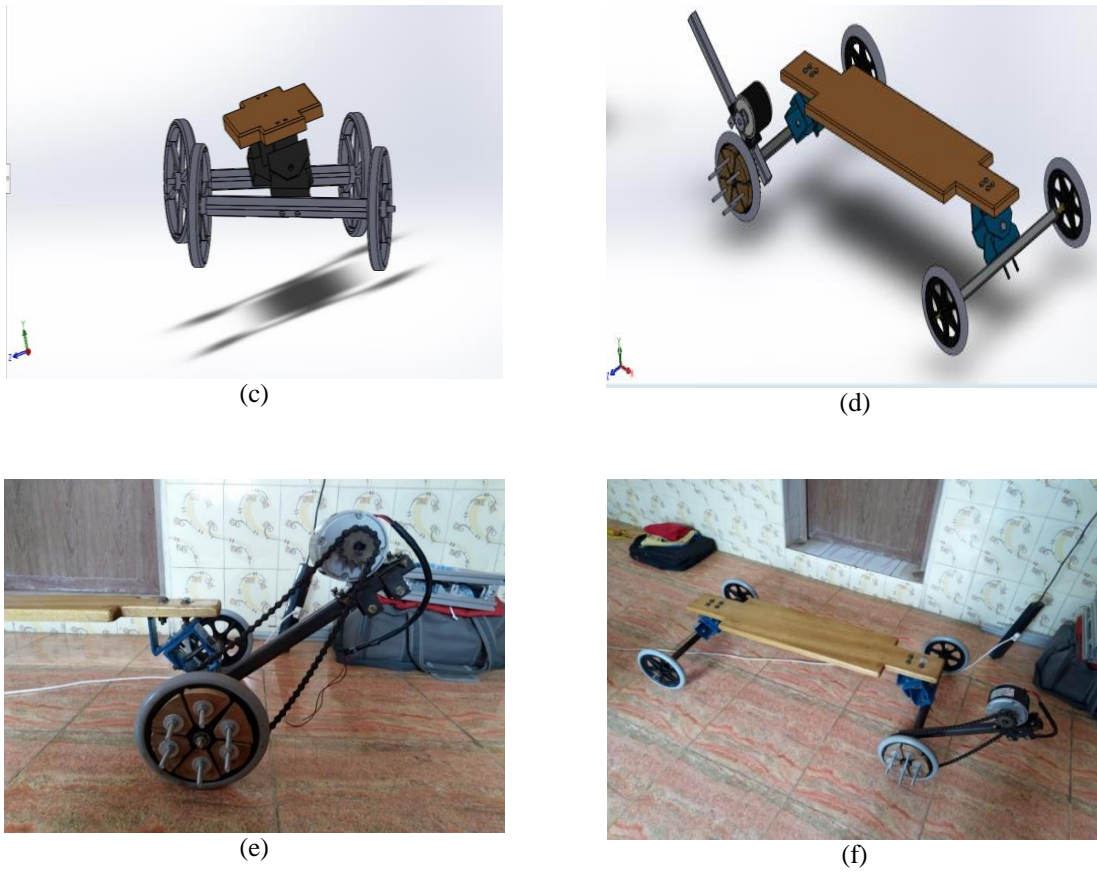

Figure 7. Step by Step procedure for hardware implementation

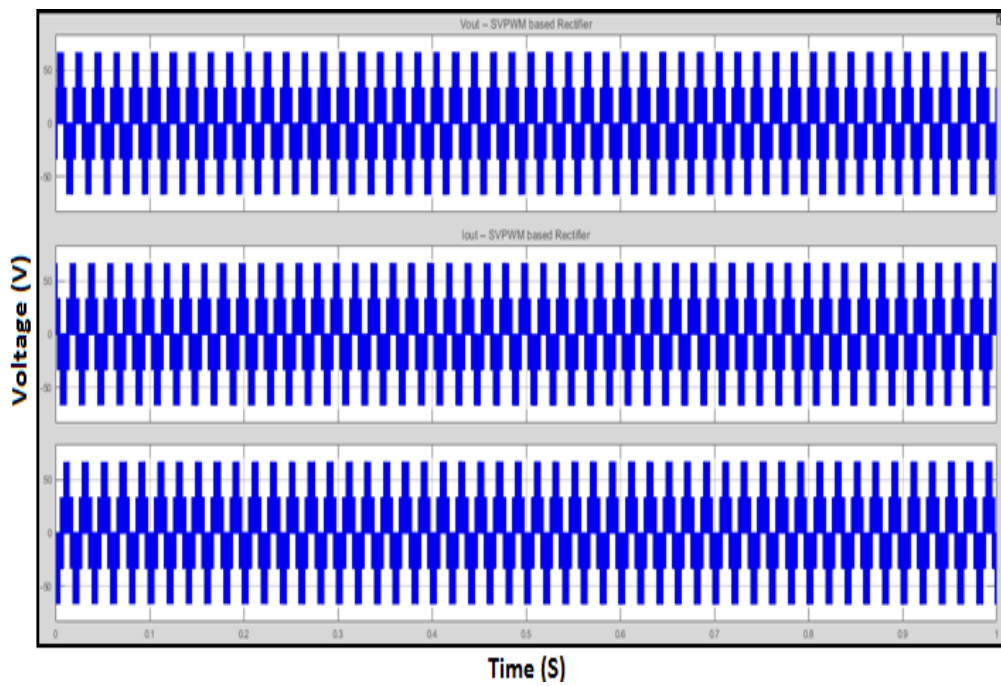

Figure 8. Output voltage of Space Vector Pulse Width Modulation

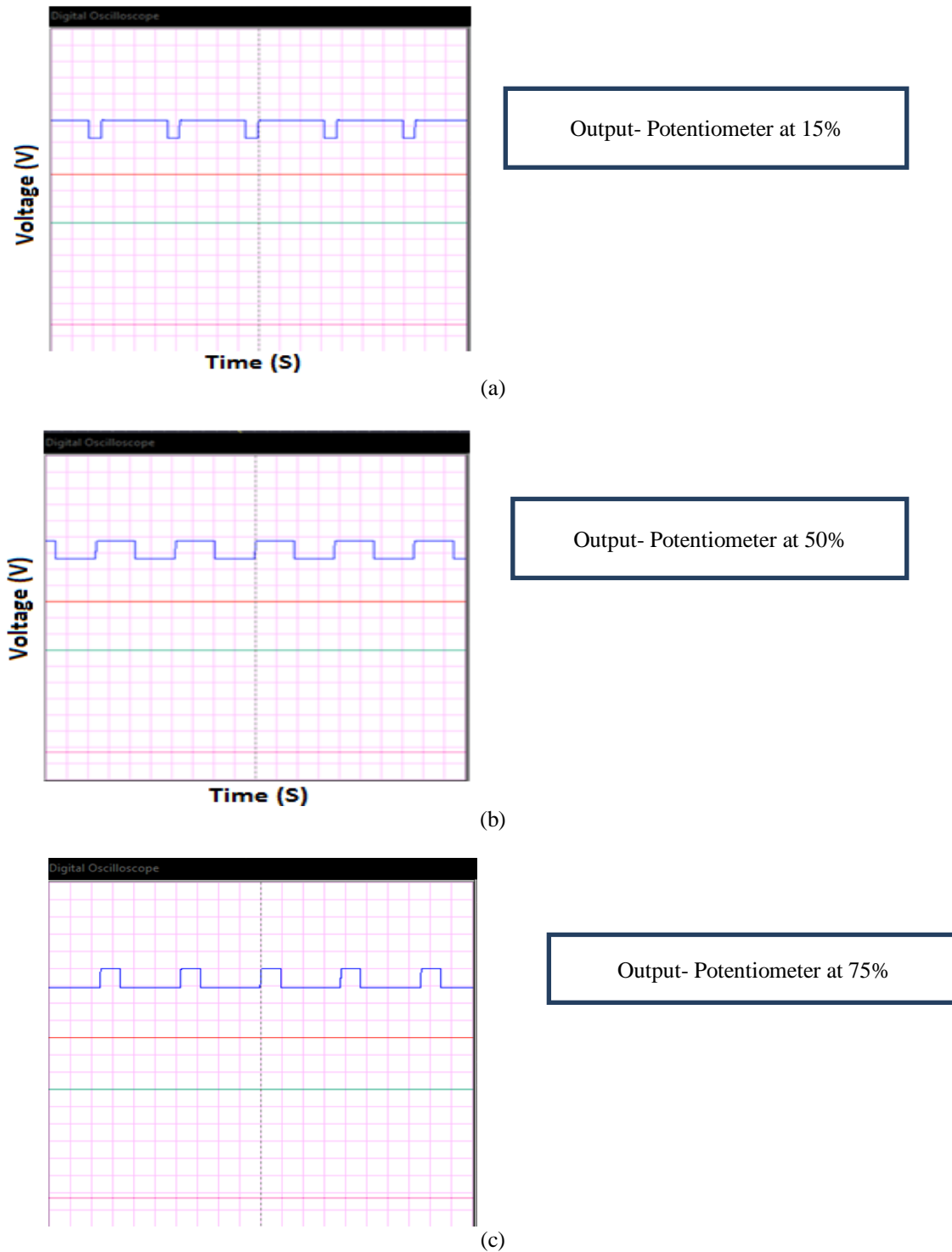

Figure 9. Output voltage graph with respect to potentiometer

## 7. CONCLUSION

The speed of the BLDC motor is being controlled by SVPWM circuit with a 555 timer. The simulation model of the skateboard was designed and studied. The speed of the motor is successfully controlled by a potentiometer which changes the duty ratio of the circuit. The given circuit proves to be efficient as SVPWM results in very low loss of power due to the use of transistors and less voltage drop across itself. The motor voltage at different duty cycle periods is obtained. This is because with the increase in duty cycle, additional voltage is applied to the motor. This means it will lead to a stronger magnetic flux

within the coil windings. Therefore, it increases the revolutions per minute. The characteristics and performance of the BLDC motor speed system was studied. The skateboard is constructed out of wood and the metal parts is used for developing the truck system. The trucks regulate the turning of the board. The wheels chosen are in accordance with the Indian roads and will be able to operate on off-roads and is highly cost efficient as compared to mountain boards.

## REFERENCES

- [1] K. M. Raza, et al., "Speed Control of DC Motor by using PWM," Electrical Engg Department, MIT Moradabad.
- [2] A. S. M. Bakibillah, et al., "Microcontroller based Closed Loop Speed Control of DC Motor using PWM Technique," *International Journal of Computer Applications*, 2014.
- [3] V. R. Stefanovic, "Recent trends in variable ac drives," *IPEC-Tokyo Conf. Rec.*, pp. 438-449, 1983.
- [4] K. Iizuka, et al., "Micro-computer control for sensorless brushless motor," *IEEE Trans. Industry Applications*, vol. IA-21, pp. 595-601, 1985.
- [5] M. D. Erdman, et al., "Electronically commutated dc motors for the appliance industry," *IEEE-IAS Conf. Rec.*, pp. 1339-1345, 1984.
- [6] S. Ogasawara and H. Akagi, "An approach to position sensorless drive for brushless dc motors," *IEEE-IAS Conf. Rec.*, pp. 443-447, 1990.
- [7] N. Matsui and H. Ohasi, "DSP-based adaptive control of a brushless motor," *Proc. IEEE/IAS Ann. Mtg.*, 1988.
- [8] A. A. Abounaga, et al., "A novel low-cost high-performance single-phase adjustable-speed motor drive using PM brushless DC machines: IIT's design for 2003 future energy challenge," *Proc. 19th Annu. IEEE Appl. Power Electron. Conf.*, pp. 1595-1603, 2004.
- [9] C. W. Lu, "Torque controller for brushless DC motors," *IEEE Trans. Ind. Electron.*, vol. 46, pp. 471-473, 1999.
- [10] F. Rodriguez and A. Emadi, "A novel digital control technique for brushless DC motor drives," *IEEE Trans. Ind. Electron.*, vol. 54, pp. 2365-2373, 2007.
- [11] R. Dubey and P. Agarwal, "Programmable logic devices for motion control—A review," *IEEE Trans. Ind. Electron.*, vol. 54, pp. 559-566, 2007.
- [12] T. Kennjo and S. Nagamori, "Permanent Magnet Brushless DC Motors," U.K., Oxford, Clarendon, 1985.
- [13] T. J. E. Miller, "Brushless Permanent Magnet and Reluctance Motor Drives," New York, Oxford Univ. Press, 1989.
- [14] L. Yong, et al., "Commutation torque ripple minimization in direct torque controlled PM brushless DC drives," *IEEE Trans. Ind. Electron.*, vol. 43, pp. 1012-1021, 2007.
- [15] R. Palanisamy, K. Vijayakumar, V. Venkatachalam, K. Saravanan, "Simulation of various DC-DC converters for photovoltaic system", *International Journal of Electrical and Computer Engineering (IJECE)*, Vol. 9, No. 2, pp. 917-925, April 2019.
- [16] Z. Chen, et al., "New adaptive sliding observers for position and velocity sensorless controls of brushless DC motors," *IEEE Trans. Ind. Electron.*, vol. 47, pp. 582-591, 2000.
- [17] F. Rodriguez, et al., "A novel digital control technique for trapezoidal brushless DC motor drives," *Proc. Power Electron. Technol. Conf.*, 2004.
- [18] P. Pillay and R. Krishnan, "Modeling of permanent magnet motor drives," *IEEE Trans. Ind. Electron.*, vol. 35, pp. 537-541, 1988.
- [19] Palanisamy, A.U Mutawakkil, K. Vijayakumar, "Hysteresis SVM for Coupled Inductor z Source Diode Clamped 3-level Inverter based grid Connected PV System", *International Journal of Power Electronics and Drive Systems*, vol. 7, no. 4, Dec 2016.
- [20] P. Pillay and R. Krishnan, "Modeling simulation and analysis of permanent-magnet motor drives. II. The brushless DC motor drive," *IEEE Trans. Ind. Appl.*, vol. 25, pp. 274-279, 1989.
- [21] M. Tomita, et al., "New sensorless control for brushless DC motors using disturbance observers and adaptive velocity estimations," *IEEE Trans. Ind. Electron.*, vol. 45, pp. 274-282, 1998.
- [22] N. Matsui, "Sensorless PM brushless DC motor drives," *IEEE Trans. Ind. Electron.*, vol. 43, pp. 300-308, 1996.
- [23] I. Boldea and S. A. Nasar, "Electric Drives," FL, Boca Raton, CRC Press, 1999.
- [24] R. Palanisamy, K. Vijayakumar, Komari Nikhil, Madhumathi Iyer, Ramachandar Rao, "A Proposed SVM for 3-level Transformer-less Dual Inverter Scheme for Grid Connected PV System", *Indian Journal of Science and Technology*, vol. 9, no. 42, Nov. 2016.
- [25] L. A. Cabrera, et al., "Learning techniques to train neural networks as a state selector for inverter-fed induction machines using direct torque control," *IEEE Trans. Power Electron.*, vol. 12, pp. 788-799, 1997.
- [26] 14. Gadoue, S.M., Giaouris, D., and Finch, J.W., 2009. Artificial intelligence-based speed control of DTC induction motor drives—A comparative study. *Journal Electric Power System Research*, 79: 210-219.
- [27] Ren, T.J., and Chen, T.C., 2006. Robust speed-controlled induction motor drive based on recurrent neural network. *Electric Power System Research*, 76: 1064-1074.
- [28] Denai, M.A., and Attia, S.A., 2002. Fuzzy and neural control of an induction motor, *Int. Journal Appl. Math. Comput. Sci.*, 12(20): 221-233.