

Design of fiber bragg grating (FBG) temperature sensor based on optical frequency domain reflectometer (OFDR)

Nani Fadzlina Naim¹, Siti Noor Maslizan Sudin², Suzi Seroja Sarnin³,
Norsuzila Ya'acob⁴, Latifah Sarah Supian⁵

^{1,2,3,4}Faculty of Electrical Engineering, Universiti Teknologi MARA (UiTM), Malaysia

⁵Fakulti Kejuruteraan, Universiti Pertahanan Nasional Malaysia, Malaysia

Article Info

Article history:

Received Mar 18, 2019

Revised Dec 3, 2019

Accepted Dec 11, 2019

Keywords:

Fiber bragg grating
Optical frequency domain
Reflectometer (OFDR)
RF spectrum analyzer
Temperator sensor

ABSTRACT

In this paper, the simulation of Fiber Bragg Grating (FBG) as a temperature sensor is conducted. The FBG temperature sensor is designed based on Optical Frequency Domain Reflectometer (OFDR) concept. A continuous wave (CW) laser is used as the optical source and it is transmitted to two FBGs. The two FBGs reflection spectra will produce a beat frequency that can be detected using a Radio Frequency (RF) spectrum analyzer. Any temperature change will shift Bragg wavelength, thus produce a shift for the beat frequency. In this work, an FBG with temperature sensitivity 10 pm/°C is employed. It is found that by using this technique, a high-resolution temperature sensor can be designed with temperature resolution of 0.1°C.

Copyright © 2020 Institute of Advanced Engineering and Science.
All rights reserved.

Corresponding Author:

Nani Fadzlina Naim,
Fakulti Kejuruteraan Elektrik,
Universiti Teknologi MARA (UiTM),
40450 Shah Alam, Selangor, Malaysia.
Email: nanifadzlina@uitm.edu.my

1. INTRODUCTION

Nowadays, there is a rapid growth of optical fiber technology, especially on fiber optic sensor. In various smart structures such as pipeline, bridge, aircraft, ship, and others, one of the most important parameters is temperature [1]. This is because most of the structures always been exposed to any physical changes like temperature, strain, and pressure and can result in damage, destruction, and risks to human. Recently, numerous optical temperature sensors have been proposed using various techniques. For instance, temperature sensors based on Long Period Gratings (LPG) [2], fiber tapers [3-4], multimode interference [5] and Fiber Bragg Gratings (FBG) [6-13]. To the best of the authors' knowledge, FBG is one of the most renowned optical temperature sensors.

Theoretically, any temperature change will shift the FBG Bragg wavelength. Commonly, the Bragg wavelength shift of FBG is monitored by using an optical spectrum analyzer (OSA). However, OSA has its own limitations in response time, resolution, weight, size, and cost [14]. To overcome these issues, RF spectrum analyzer is introduced. Hence, Fiber Bragg Grating (FBG) as temperature sensor using RF spectrum analyzer is proposed. In this work, we are focused on technique to be used to designing a high-resolution temperature sensor. Aside from this technique, there are some techniques from another researcher that can relate to FBG temperature sensor. As studied by [15], they develop fiber-optic sensor that have a high-resolution and high-speed temperature measurement based on silicon Fabry-Pérot cavity. The silicon pillar is attached on the tip of a single-mode fiber to fabricate it and have $6 \times 10^{-4} \text{C}$ as the temperature resolution. [16] Has researched the sensor head of FBG to be focused with convex and hand lens, evaluated by varying of focusing elements in harsh environments. They discovered that for both systems, the Bragg

wavelength shift is increase proportionally with temperature. Aside from improving the interrogator's resolution [17], in order to obtain a high-resolution temperature or strain sensing, we must increase the FBG's sensitivity.

Fiber optic technology plays important roles in telecommunication field [18]. Temperature, rotations, vibrations, displacement, and pressure can be detected by fiber optic sensors [19]. In the field of remote sensing, fibers have so many roles because they require no electrical power at the remote location and another reason is they have tiny size [20]. As stated by [21], there are two groups of fiber optic sensors that are extrinsic and intrinsic fiber optic sensor. The difference is that, when the sensing takes place in a region outside the fiber, it is extrinsic fiber optic. While for intrinsic fiber optic, an optical fiber itself acts as the sensing element and often used to measure strain, temperature and pressure. Extrinsic fiber optic sensors use an external transducer and have a function to calculate rotation, acceleration, vibration, displacement, twisting and torque.

According to Bragg's law [22], Bragg wavelength occurred when light at specific wavelength is reflected from FBG and passes through into the fiber. The Bragg wavelength depends on the grating period and the refractive index of fiber. The Bragg wavelength equation is given in the (1):

$$\lambda_B = 2 * n_{eff} * \Lambda \quad (1)$$

where λ_B is Bragg wavelength of the fiber, n_{eff} is effective refractive index of the core and Λ is grating pitch. The relationship between wavelength shift and frequency shift can be calculated as follows:

$$\Delta f = \frac{c(\Delta\lambda)}{\lambda^2} \quad (2)$$

where Δf is the change in frequency, where $\Delta\lambda$ is the change in wavelength, c is the speed of light and λ is the Bragg wavelength [23]. Enough wavelength spacing must be specified between FBG's center wavelengths in order to prevent interference between FBGs when the system uses more than one FBG on single mode fiber. It is given that 5 nm wavelength spacing for strain measurements and 1 nm wavelength spacing for temperature sensing [24]. By differentiating the wavelength expression (3), the temperature dependence can be determined as follows:

$$\begin{aligned} \left. \frac{\Delta\lambda_B}{\lambda_B} = \frac{\Delta(n_{eff} \Lambda)}{n_{eff} \Lambda} \right|_{\varepsilon=C\text{onstant}} &= \left(\frac{1}{\Lambda} \frac{\Delta\Lambda}{\Delta T} + \frac{1}{n_{eff}} \frac{\Delta n_{eff}}{\Delta T} \right) \Delta T \\ &= (\alpha + \zeta) \Delta T = k_T \Delta T \end{aligned} \quad (3)$$

where k_T is Bragg grating's thermal sensitivity, ζ is temperature dependence of the index of refraction and α is thermal expansion coefficient of the fiber. The thermal sensitivity can be calculated by assume the value for temperature range, $\alpha = 0.55 \times 10^{-6}/^\circ\text{C}$ and $\zeta = 5.77 \times 10^{-6}/^\circ\text{C}$ and given by (4).

$$\frac{\Delta\lambda_B}{\lambda_B} = k_T \Delta\varepsilon = 6.32 \lambda_B \quad (4)$$

Thus, the temperature sensitivity for an FBG at a Bragg wavelength of 1540 nm is 10 pm/ $^\circ\text{C}$ [25]. In this paper, a simulation of FBG temperature sensor has been conducted. In this design, the Optical Frequency Domain Reflectometer (OFDR) concept has been deployed whereas two FBGs are used in this setup. It is found that by using this technique, a higher resolution of FBG temperature sensor is produced with temperature resolution of 0.1 $^\circ\text{C}$.

2. DESIGN PRINCIPLE

The setup for the FBG sensor is demonstrated in Figure 1 which includes CW laser source, two power splitters, four FBGs, an Erbium-doped fiber amplifier (EDFA), a photodetector PIN and RF Spectrum analyzer. The simulation is performed using OptiSystem simulation software. We employ four FBGs in this sensing system. FBG₁ and FBG₂ as the reference or we called it as reference arm with bandwidth of 0.0025 nm each and wavelength of 1540 nm and 1540.001 nm, respectively. Bragg wavelength of FBG₃ is fixed to 1540 nm while for FBG₄, the value of Bragg wavelength is increase from 1540.001 nm with Bragg wavelength increment of 0.001 nm, 0.002 nm, and 0.003 nm. Both FBG₃ and FBG₄ have bandwidth of 0.0025 nm. Principally, the temperature changes are applied on FBG₄ and this will cause Bragg wavelength changes. As the temperature is increased, the Bragg wavelength will also increase. The Bragg wavelength

change of FBG₄ will interfere with Bragg wavelength of FBG₃. The interference signals contain beat frequency which will appear peaks in the Radio Frequency (RF) spectrum analyzer. Figure 1 shows the simulation model using OptiSystem software. In this simulation, there are a few parameters from real specifications were given from datasheet and default parameters had been used. The most important parameter is Fiber Bragg gratings (FBGs) parameters and other parameters that had been used in this simulation which includes CW laser power is 0 dm, reference wavelength is set to 1540 nm, EDFA length is 5 m and bit rate used in this simulation is 200 Mbit/s.

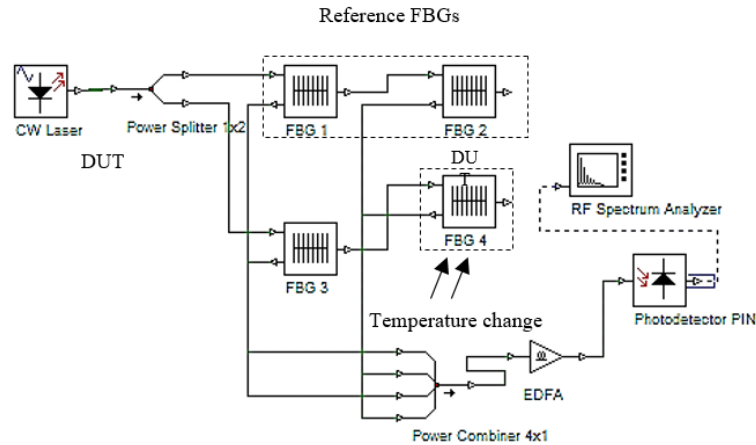

Figure 1. FBG temperature sensor simulation model using OptiSystem software

3. RESULT AND DISCUSSION

Figure 2 demonstrates the characteristic of FBG sensor under various temperature changes. The simulated result is linear. The characterization result also shows that for every 25°C temperature change, 0.25 nm wavelength shift is shifted. The temperature sensitivity of the FBG used in the simulations is 10.0 pm/°C. From the simulation, we also measured the sensitivity of the strain from the data collected and we found the strain sensitivity to be 1.2 pm/με. Figure 3 shows a linear graph to represent the characteristic of FBG sensor under various strain changes. The characterization result also shows that for every 200 με applied to FBG₄, a 0.24 nm wavelength is recorded.

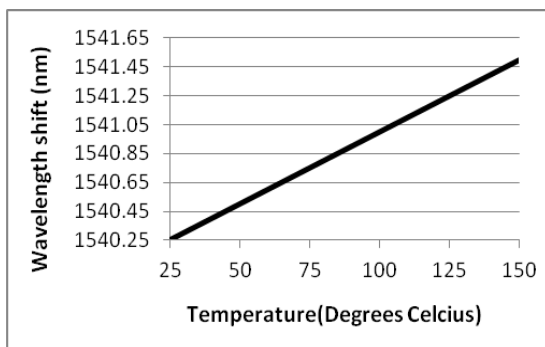

Figure 2. Wavelength shift versus temperature relationship

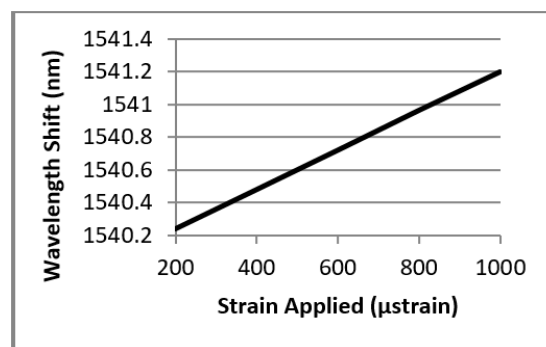
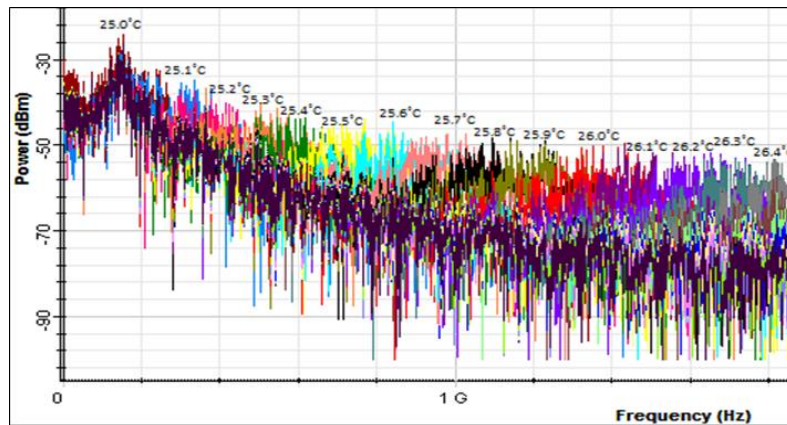

Figure 3. Wavelength shift versus strain relationship

Any temperature change will shift Bragg wavelength at 10 pm/°C. In this simulation, FBG₄ is the Device under Test (DUT) whereas the temperature of FBG₄ is varied. In this simulation, any temperature changes of 0.1°C will cause a wavelength shift of 0.001 nm. The reflected spectrum of FBG₄ is illustrated in Figures 4, 5, and 6. In this project, it is simulated according to the resolution bandwidth of 1MHz, 3MHz and 10 MHz and to the Bragg wavelength shift of 0.001nm, 0.002nm and 0.003 nm.

Figures 4, 5 and 6 show reflected spectrum of FBG₄ with resolution bandwidth and wavelength shift of 0.001 nm, 0.002 nm and 0.003 nm due to temperature change of 0.1°C, 0.2°C, and 0.3°C, respectively. Figure 4 shows the FBG₄ reflection spectrum with temperature change of 0.1°C which causes a wavelength shift of 0.001 nm. Figure 4(a), (b), and (c) show the FBG₄ spectrum with resolution bandwidth of 1 MHz, 3 MHz and 10 MHz, respectively. It can be observed that Figure 4(a), (b), and (c) can clearly be analyzed. Figure 4(c) with the highest resolution bandwidth shows the best observation display in order to detect any temperature change. Thus, the higher the resolution bandwidth of RF spectrum analyzer, the easier the analyses to detect the temperature change.



(a)

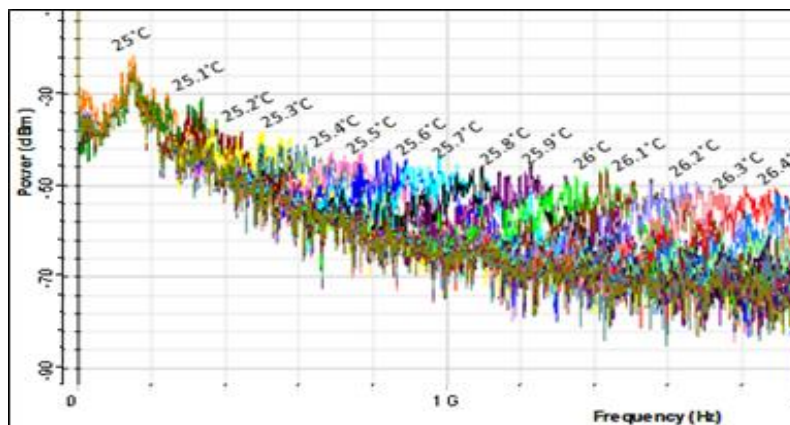

(b)

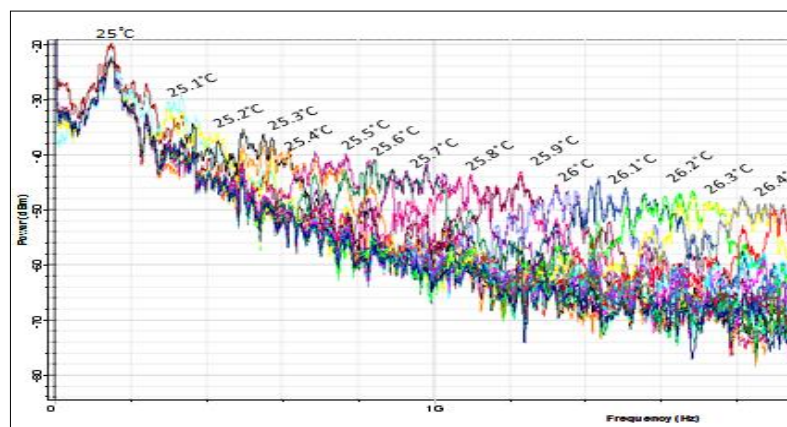

(c)

Figure 4. Temperature change at 0.1°C for FBG₄ with Bragg wavelength shift of 0.001 nm using (a) 1 MHz, (b) 3 MHz, (c) 10 MHz of resolution bandwidth for the RF spectrum analyzer

Figure 5 shows the FBG₄ reflection spectrum due to temperature change of 0.2°C. This will cause Bragg wavelength change of 0.002 nm. Figure 5(a), (b), and (c) display the FBG₄ spectrum with RF spectrum analyzer resolution bandwidth of 1 MHz, 3 MHz and 10 MHz, respectively. It can be perceived that the spectrum with temperature change of 0.2°C can be clearly seen as compared to temperature change of 0.1°C. It is also found that the highest bandwidth of RF spectrum analyzer which is 10 MHz produce the best display for analysis.

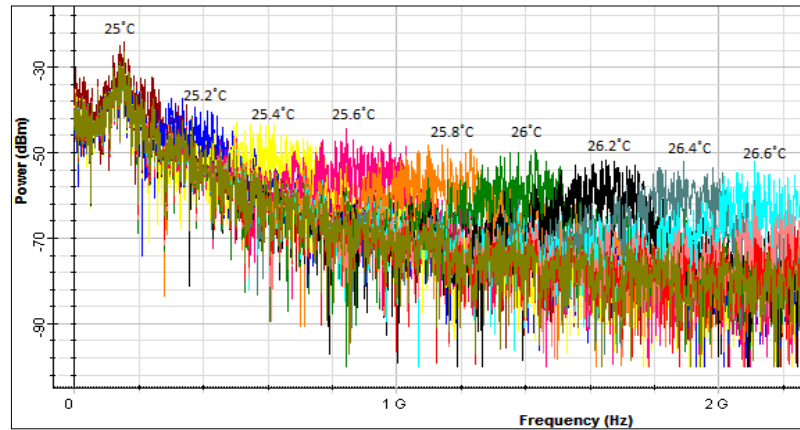

(a)

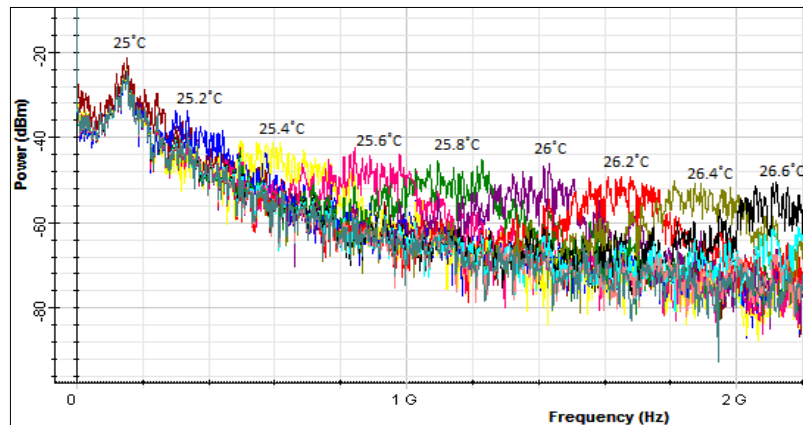

(b)

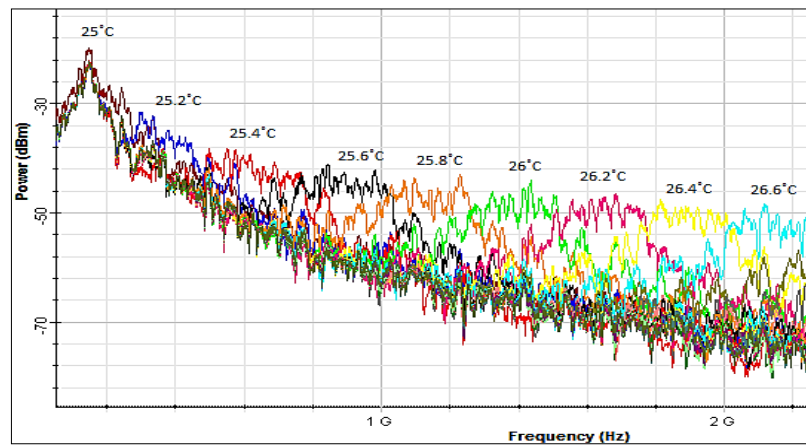

(c)

Figure 5. Temperature change at 0.2°C for FBG₄ with Bragg wavelength shift of 0.002 nm using (a) 1 MHz, (b) 3 MHz, (c) 10 MHz of resolution bandwidth for the RF spectrum analyzer

Figure 6(a) to Figure 6(c) show the FBG₄ spectrum for temperature shift of 0.3°C and this will cause wavelength change of 0.003 nm with RF spectrum analyzer resolution bandwidth of 1 MHz, 3 MHz and 10 MHz, respectively. The highest resolution bandwidth of 10 MHz gives the best display of FBG₄ for spectrum analysis. It can also be seen that the highest temperature changes of 0.3°C will result with the best display for analysis as compared to Figure 4 and Figure 5. Thus, the higher the temperature shift and the higher the RF spectrum analyzer resolution bandwidth will produce a higher quality display for spectrum analysis. In summary, this temperature sensor is capable to monitor the smallest temperature change or temperature resolution of 0.1°C with the best resolution bandwidth of RF spectrum analyzer of 10 MHz. However, other resolution bandwidth of spectrum analyzer can still be implemented in the temperature sensor system.

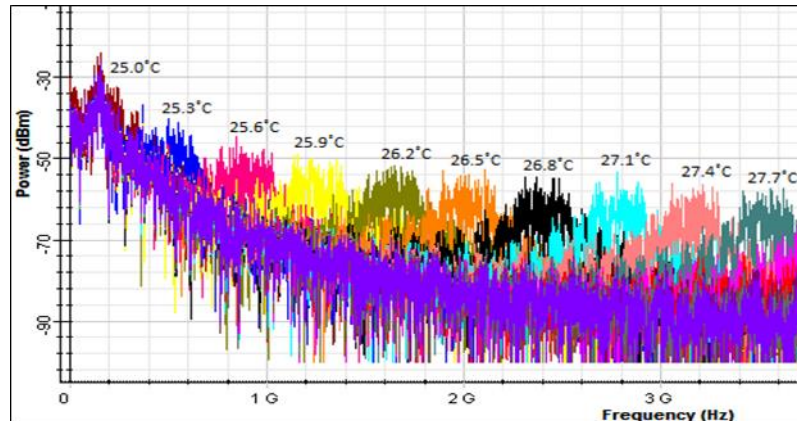

(a)

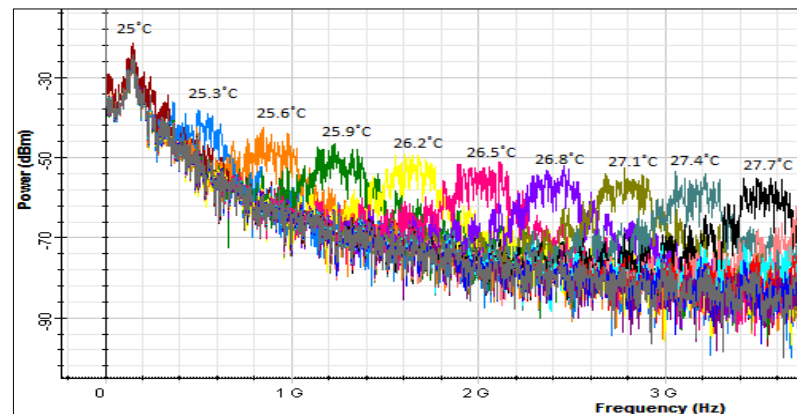

(b)

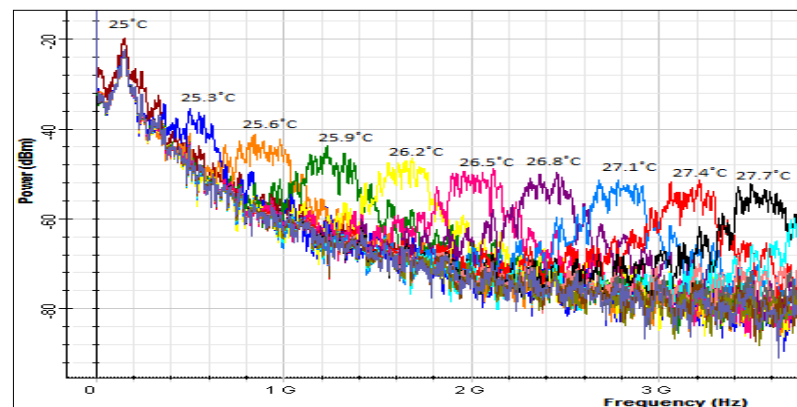

(c)

Figure 6. Temperature change at 0.3°C for FBG₄ with Bragg wavelength shift of 0.003 nm using (a) 1 MHz, (b) 3 MHz, (c) 10 MHz of resolution bandwidth for the RF spectrum analyzer

4. CONCLUSION

In conclusion, an FBG temperature sensor based on OFDR has been demonstrated. It employs a CW laser as optical source, four FBGs and an RF spectrum analyzer to analyze the FBG Spectrum. The FBG reflected spectrum will be observed for analysis. Any temperature change will cause the FBG Bragg wavelength to shift. In this simulation, FBGs with sensitivity of 10 pm/°C and 1.2 pm/με strain are employed. Using this technique, a high-resolution temperature sensor is designed with the temperature resolution of 0.1°C which can clearly be observed using a low-cost RF spectrum analyzer.

ACKNOWLEDGEMENTS

The author wishes to thank Universiti Teknologi MARA (UiTM) under Bestari research grant 600-IRMI/PERDANA 5/3 BESTARI (082/2018) for supporting this project.

REFERENCES

- [1] A. Mendez, "Fiber Bragg grating sensors: A market overview," *Proceedings of SPIE - Third European Workshop on Optical Fibre Sensors*, vol. 6619, pp. 661905-1–6, 2007.
- [2] Y.-G. Han, S.B. Lee, C.-S. Kim, J.U. Kang, U.-C. Paek, and Y. Chung, "Simultaneous measurement of temperature and strain using dual long-period fiber gratings with controlled temperature and strain sensitivities," *Optics Express*, vol. 11, no. 5, pp. 476–481, 2003.
- [3] P. Lu, L. Men, K. Sooley, and Q. Chen, "Tapered fiber Mach-Zehnder interferometer for simultaneous measurement of refractive index and temperature," *Appl. Phys. Lett.*, vol. 94, no. 13, pp. 131110-1–3, 2009.
- [4] B. Musa *et al.*, "Investigating the effect of taper length on sensitivity of the tapered-fiber based temperature sensor," *Jurnal Teknologi*, vol. 78, no. 3, pp. 135–140, 2016.
- [5] S. Silva *et al.*, "Ultrahigh-sensitivity temperature fiber sensor based on multimode interference," *Appl. Opt.*, vol. 51, no. 16, pp. 3236–3242, 2012.
- [6] J.-L. Kou, S.-J. Qiu, F. Xu, and Y.-Q. Lu, "Demonstration of a compact temperature sensor based on first-order Bragg grating in a tapered fiber probe," *Opt. Exp.*, vol. 19, no. 19, pp. 18452–18457, 2011.
- [7] B.-O. Guan, H.-Y. Tam, X.-M. Tao, and X.-Y. Dong, "Simultaneous strain and temperature measurement using a superstructure fiber Bragg grating," *IEEE Photon. Technol. Lett.*, vol. 12, no. 6, pp. 675–677, Jun. 2000.
- [8] D. Zhang, J. Wang, Y. Wang, and X. Dai, "A fast response temperature sensor based on fiber Bragg grating," *Meas. Sci. Technol.*, vol. 25, no. 7, pp. 075105-1-4, 2014.
- [9] S. Rota-Rodrigo, L. Rodriguez-Cobo, M. A. Quintela, J. M. Lopez-Higuera, and M. Lopez-Amo, "A switchable erbium doped fiber ring laser system for temperature sensors multiplexing," *IEEE Sensors J.*, vol. 13, no. 6, pp. 2279–2283, Jun. 2013.
- [10] Y.-G. Han, "Triple-wavelength switchable multi wavelength erbium-doped fiber laser based on a highly nonlinear photonic crystal fiber," *J. Korean Phys. Soc.*, vol. 56, no. 41, pp. 1251–1255, 2010.
- [11] S. Anania, A. Unnikrishnan, A. Aparna, G. R. Parvathi, S. D. Baby Sreeja, and P. Mohan, "analytical study of FBG spectrum for temperature sensing applications," *Proceedings of the 2nd International Conference on Inventive Communication and Computational Technologies (ICICCT)*, Coimbatore, India, pp. 1109–1113, 2018.
- [12] V. Mishra, M. Lohar, and A. Amphawan, "Improvement in temperature sensitivity of FBG by coating of different materials," *Optik*, vol. 127, no. 2, pp. 825–828, 2016.
- [13] W. Chen *et al.*, "Performance assessment of FBG temperature sensors for laser ablation of tumors," *IEEE International Symposium on Medical Measurements and Applications (MeMeA) Proceedings*, Turin, pp. 324–328, 2015.
- [14] V. R. Mamidi *et al.*, "Fiber Bragg grating-based high temperature sensor and its low cost interrogation system with enhanced resolution," *Optica Applicata*, vol. 44, no. 2, pp. 299–308, 2014.
- [15] A.M. Hatta, G. Rajan, Y. Semenova, and G. Farrell, "SMS fibre structure for temperature measurement using a simple intensity-based interrogation system," *Electron. Lett.*, vol. 45, no. 21, pp. 1069–1070, 2009.
- [16] S. Daud and A.F.A. Noorden, "Fibre Bragg grating sensor system for temperature application," *Jurnal Teknologi (Sciences and Engineering)*, vol. 78, no. 3, pp. 39–42, 2016.
- [17] N. Kuse, A. Ozawa, and Y. Kobayashi, "Static FBG strain sensor with high resolution and large dynamic range by dual-comb spectroscopy," *Opt. Express*, vol. 21, no. 9, pp. 11141–11149, 2013.
- [18] "Fiber optic sensors: An introduction for engineers and scientists. (n.d.)," [Online]. Available: <http://www.worldcat.org/wcpa/servelet/org.oclc.lac.ui.DialABookServlet?oclcnum=769325498>
- [19] T. Agarwal, "Introduction to fiber optic sensors and their types with applications," *Elprocus Electronics , Projects, Focus, Elprocus*, 2014, [Online]. Available: www.elprocus.com/different-types-of-fiber-optic-sensors/.
- [20] K. T. V. Grattan and B. T. Meggitt, "Optical Fiber Sensor Technology," vol. 2, Devices and Technology, Chapman & Hall, London, 1998.
- [21] Daisy Bhor, "How fiber optic temperature sensor works," *Medium, Medium Corporation*, 2015. [Online]. Available: medium.com/@daisybhor/how-fiber-optic-temperature-sensor-works-86480abf2112.
- [22] B. Junjie, L. Jianqing, and W. Ying, "Composite tactile sensor array using fiber Bragg grating sensors and measuring system," *9th Int. Conf. on Optical Communications and Networks*, pp. 24-27, 2010.

- [23] V.J. Urick, K.J. Williams, J.D. McKinney, and V.J. Urick, "Sources of Noise in Fiber Optic Links," In *Fundamentals of Microwave Photonics*, vol. 1, John Wiley & Son, New Jersey, pp. 109–110, 2015.
- [24] National Instruments, "Fundamentals of Fiber Bragg Grating (FBG) Optical Sensing," *using NI-TimeSync to Configure IEEE 1588 and 802.1AS Time References - National Instruments*, Jan. 2016.
- [25] S.W. James, M.L. Dockney, and R.P. Tatam, "Simultaneous independent temperature and strain measurement using in-fiber Bragg grating sensors," *Electronics Lett.*, vol. 32, pp. 1133–1134, 1996.

BIOGRAPHIES OF AUTHORS



Nani Fadzlina Naim received the B.Eng. degree in Electrical and Electronics Engineering and M.Eng degree in Electronics and Communication Engineering from Universiti Teknologi Malaysia (UTM) in 2005 and 2007, respectively. She received her PhD in 2015 in Electrical, Electronics and Systems Engineering from Universiti Kebangsaan Malaysia (UKM). She is currently a senior lecturer at Faculty of Electrical Engineering, Universiti Teknologi MARA (UiTM). Her current research interests are in the area of design optical networks, optical network monitoring, optical communication, optical sensing technology and its application.



Siti Noormaslizan Sudin received the B.Eng. degree in Electronics Engineering from Universiti Teknologi MARA (UiTM) Shah Alam in 2018. She is currently a Young Executive Apprentice at Sultan Mahmud Hydro Electric Power Station, operated by Tenaga Nasional Berhad (TNB). She has a background in Communication system and holds keen interests in the area of optical network and optical sensing technology.



Suzi Seroja Sarnin received her Bachelor of Electrical and Electronics (B. Eng) in Communication field in 1999 from Universiti Teknologi Malaysia (UTM), Skudai, Johor. She completed her Master of Microelectronics (MSc.) from Universiti Kebangsaan Malaysia in 2005. She received her PhD in Electrical engineering in 2018. Currently, she is a senior lecturer at Faculty of Electrical Engineering, Universiti Teknologi MARA (UiTM). Her research interests are in wireless communication and Internet of Thing (IoT).



Norsuzila Ya'acob is Associate Professor at the Department of Communication Engineering, Faculty of Electrical Engineering, Universiti Teknologi MARA (UiTM). In 2010, she was awarded a PhD degree in Electrical, Electronic & Systems Engineering from Universiti Kebangsaan Malaysia (UKM), Malaysia. She received her MSc degree from University Putra Malaysia (UPM) in 2000. She also obtained her B.Eng degree from University of Putra Malaysia (UPM), Malaysia in Electronics & Computer Engineering in 1999. She is the Deputy Director for UiTM Satellite Centre at the FKE. Her research interests include Satellite, Space Weather, Remote Sensing, Mobile Communication and Signal Processing.



L. S. Supian received the B.Eng degree in Electrical and Computer Engineering from Stevens Institute of Technology, New Jersey, USA, M.Eng degree in Communication and Computer from Universiti Kebangsaan Malaysia, Bangi, Malaysia in 2009 and 2011 respectively. In 2012 to 2015, she joined the Computer and Network Research Group in the Faculty of Engineering, Universiti Kebangsaan Malaysia as a graduate Ph.D student in optical communication. Currently she works as a lecturer in Universiti Pertahanan Nasional Malaysia (National Defence University of Malaysia). Her research interests include polymer optical fibers technology, optical waveguides and fiber lasers.