

## Optimal tuning linear quadratic regulator for gas turbine by genetic algorithm using integral time absolute error

Jamal M. Ahmed

College of Electronics Engineering, Ninevah University, Ninevah, Iraq

---

### Article Info

#### Article history:

Received Feb 20, 2019

Revised Oct 10, 2019

Accepted Oct 18, 2019

---

#### Keywords:

Gas Turbine

Genetic Algorithm

ITAE

LQR

---

### ABSTRACT

For multiple input-multiple output (MIMO) systems, the most common control strategy is the linear quadratic regulator (LQR) which relies on state vector feedback. Despite this strategy gives very good result, it still has trial and error procedure to select the values of its weight matrices which plays a important role in reaching to the desired system performance. In order to overcome this problem, the Genetic algorithm is used. The design of genetic algorithm based linear quadratic regulator (GA-LQR) utilized Integral time absolute error (ITAE) as a cost function for optimization. The proposed procedure is implemented on a linear model of gas turbine to control the generator spool's speed and the output power.

Copyright © 2020 Institute of Advanced Engineering and Science.  
All rights reserved.

---

### Corresponding Author:

Jamal M. Ahmed,  
College of Electronics Engineering,  
Ninevah University,  
Almajmuaa Street, Mosul, Ninevah, Iraq.  
Email: Jamal1961eng@yahoo.com

---

## 1. INTRODUCTION

One of the most common regulators that has been used in the case of MIMO systems is the Linear Quadratic Regulator (LQR) which minimizes the excursion in state trajectories of a system while requiring minimum controller effort [1-3]. Moreover, LQR provides robust stability with a minimized energy-like performance index [4]. However, the startup realizations of the regulator are not straightforward task because they need try and error selection of the parameters (definition of weight matrices) [5]. There is no analytic process of finding the parameters that obtain the optimal performance of the LQR.

Over the past couple of decades and more, Genetic Algorithm as an optimization technique has been successfully applied to a wide variety of engineering problems, because of its simplicity, global perspective, and inherent parallel processing [6]. Therefore, such optimization technique can be used to design LQR for MIMO systems in a more systematic way. The GA was used to determine the weight matrices for single-input single-output systems [7]. Other researchers used Ant Colony Optimization technique to determine the tuning parameters of the LQR [8, 9]. In this paper, as a case study to most popular industrial MIMO system, genetic algorithm based LQR is applied to linear model for the gas turbine engine (LV100) The proposed method gave systematic procedure to design LQR with optimal performance that satisfies the required design.

## 2. ENGINE GAS TURBINE MATHEMATICAL MODEL

In this model, there are two engine spools connected to the turbine and there is a recuperator that is inserted for thermodynamic efficiency improvement. Also, there are low pressure and high pressure turbines where the low pressure turbine is coupled with the vehicle transmission while the high pressure turbine is used to drive the compressor [10-12]. The schematic structure of the LV100 gas turbine is shown in Figure 1.

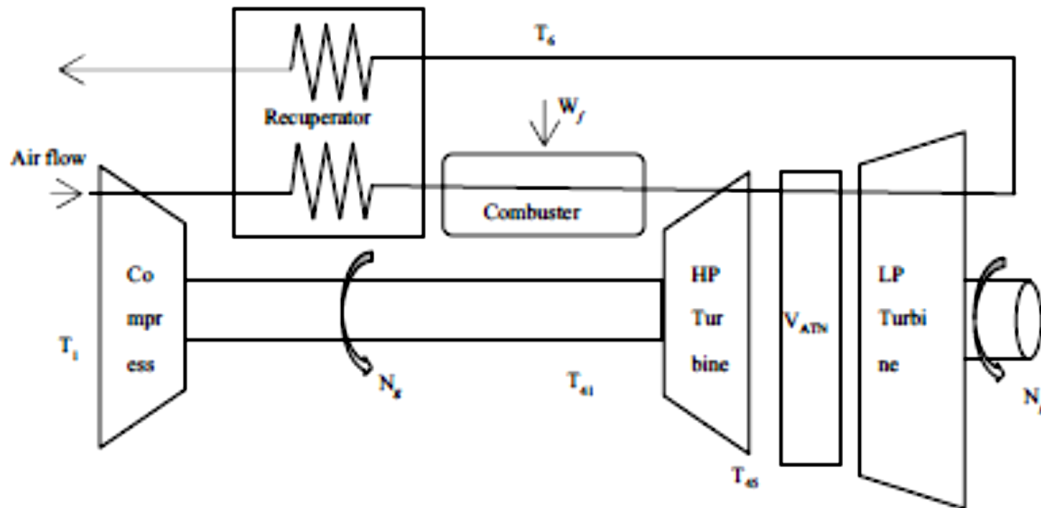

Figure 1. Gas turbine engine schematic diagram (LV100)

Practically, it is required control the two inputs, main fuel flow and output power, to adjust the gas spool speed [10]. The system has five states with two inputs and two outputs.

$$\dot{x} = Ax + Bu \quad (1)$$

$$y = Cx + Du \quad (2)$$

$u = [W_f V_{ATN}]'$  as the input,  $y = [N_g T_6]'$  as the output.

$$A = \begin{bmatrix} -1.4122 & -0.0552 & 0 & 42.9536 & 6.3087 \\ 0.0927 & -0.1133 & 0 & 4.2204 & -0.7581 \\ -7.8467 & -0.2555 & -3.3333 & 300.4167 & -4.4894 \\ 0 & 0 & 0 & -25.0000 & 0 \\ 0 & 0 & 0 & 0 & -33.3333 \end{bmatrix} \quad B = \begin{bmatrix} 0 & 0 \\ 0 & 0 \\ 0 & 0 \\ 1 & 0 \\ 0 & 1 \end{bmatrix}$$

$$C = \begin{bmatrix} 1 & 0 & 0 & 0 & 0 \\ 0 & 0 & 1 & 0 & 0 \end{bmatrix} \quad D = \begin{bmatrix} 0 & 0 \\ 0 & 0 \end{bmatrix}$$

Where:  $x_{wf}$  and  $x_{V_{ATN}}$  are the states that has been associated with actuation of the state of a normalized space representation.

$$\dot{x} = [N_g \quad N_p \quad T_6 \quad x_{wf} \quad x_{V_{ATN}}]'$$

It is clear that this state-space model is open-loop unstable since it has the following set of eigenvalues:

$$[-3.3330 \quad -0.1096 \quad 1.4088 \quad 25.0000 \quad -33.3300]$$

Moreover, the model is completely controllable as the rank of the controllability matrix is 5 which is the dimension of the state vector. The model of the gas turbine as a transfer function is represented as follow:

$$\begin{bmatrix} y_1 \\ y_2 \end{bmatrix} = \begin{bmatrix} G_{11} & G_{12} \\ G_{21} & G_{22} \end{bmatrix} \begin{bmatrix} u_1 \\ u_2 \end{bmatrix}$$

$$G_{11} = \frac{42.95s + 4.634}{s^3 + 26.53s^2 + 38.3s + 4.128}$$

$$G_{12} = \frac{300.4s^2 + 120.2s - 10.71}{s^4 + 29.86s^3 + 126.7s^2 + 131.8s + 13.76}$$

$$G_{21} = \frac{6.309s + 0.7566}{s^3 + 34.86s^2 + 51.02s + 5.504}$$

$$G_{22} = \frac{-4.489s^2 - 56.16s - 6.554}{s^4 + 38.19s^3 + 167.2s^2 + 175.6s + 18.35}$$

### 3. GENETIC ALGORITHM

Genetic Algorithm (GA) is a global-search algorithm based on the biological theory of evolution in addition to the mechanism of natural genetics. One of the main advantages of this algorithm is that it is computationally simple and does not have any assumptions about the search space where it is more likely to converge toward a global solution because it simultaneously evaluates more than one point in the parameter space. Another advantage of this method is that it is recommended for searching noisy, multimodal, and complex systems. This algorithm is different from other algorithms by its working principle, where it deals with the coding of the parameters rather than the parameters themselves. Also, in certain cases, binary coding has been suggested [13].

Regarding the search method, the search for the population of points and climbing many peaks are done in parallel, and the algorithm needs only the objective function values to manage the search without the need for other auxiliary information. To guide its search, GA uses probabilistic transition rules rather than deterministic transition rules to manage its search. For these reasons, GA gives better and more robust results than other traditional methods [14]. In GA, the population is the set of all strings, where each string is one possible solution for the problem. It starts by generating an initial population of strings randomly, then, by applying genetic operators, the population evolves from generation to generation. According to their fitness value, all the strings will be evaluated. Figure 2 shows the three main operators of the GA: reproduction, crossover, and mutation [15, 16].

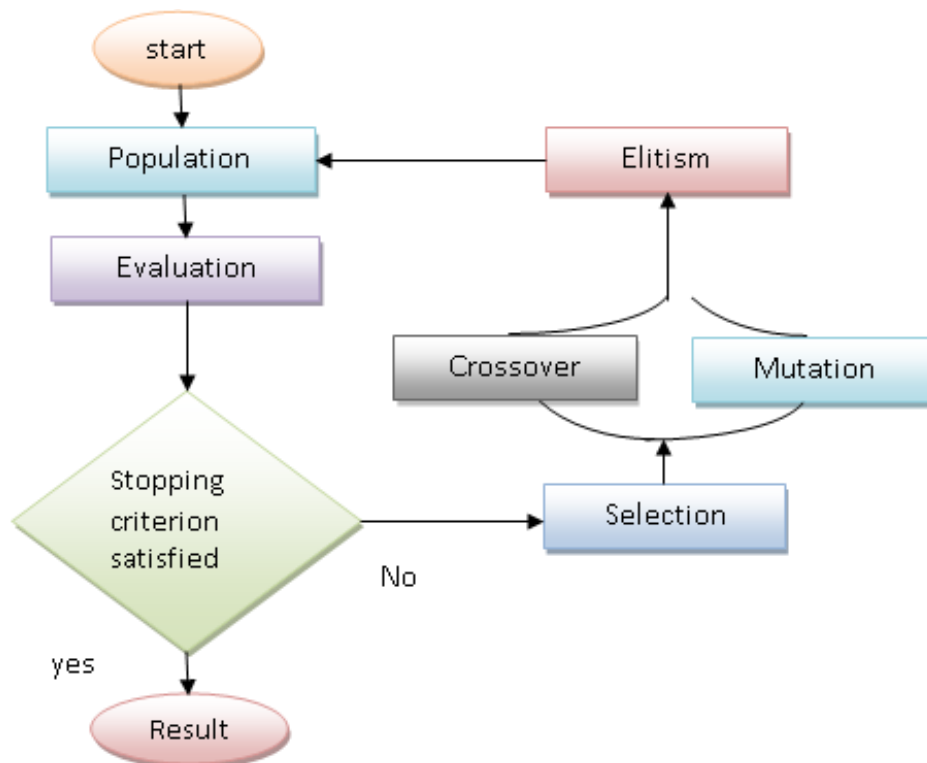

Figure 2. Flowchart of genetic algorithms

**4. LINEAR QUADRATIC REGULATOR (LQR)**

Liner quadratic regulator (LQR) is a control that working based on minimizing the index of the quadratic performance which as result provide an optimal control law [17-19]. The block diagram of the LQR is shown in Figure 3.

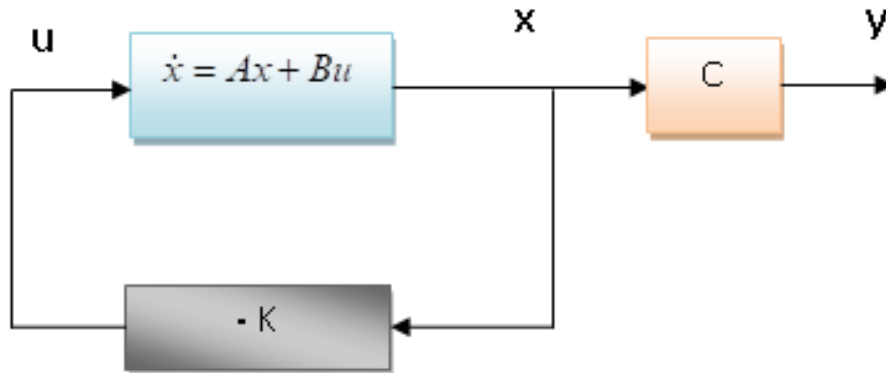

Figure 3. Linear quadratic regulator structure

The aim of the design is to minimize the quadratic cost function  $J$  by finding the suitable control input  $u$ , where  $Q$  is the state matrix while  $R$  is the weighting matrix [20, 21].

$$J = \int_0^{\infty} (x^T Q x + u^T R u) dt \tag{3}$$

According to the LQR,  $Q$  should be positive semi-definite while the weighting matrix  $R$  should be positive definite. The state space representation for a system is shown in (5).

$$\dot{x}(t) = Ax(t) + Bu(t) \tag{4}$$

where  $(A, B)$  is stable, the optimal control  $u$  is defined as:

$$u(t) = -Kx(t) \tag{5}$$

Where

$$K = [K_1 \ K_2 \ \dots \ K_n]$$

$$x = [x_1 \ x_2 \ \dots \ x_n]^T$$

The matrix  $K$  is giving by

$$K = R^{-1} B^T P \tag{6}$$

The symmetric definite matrix  $P$  is the solution of the algebraic Riccati equation given by

$$PA + A^T P + Q - PBR^{-1}B^T P = 0 \tag{7}$$

The closed-loop system which has the optimal Eigen values is given by

$$\dot{x} = A_c x = (A - BK)x \tag{8}$$

The block diagram of LQR controller of the gas turbine is shown in the Figure 4

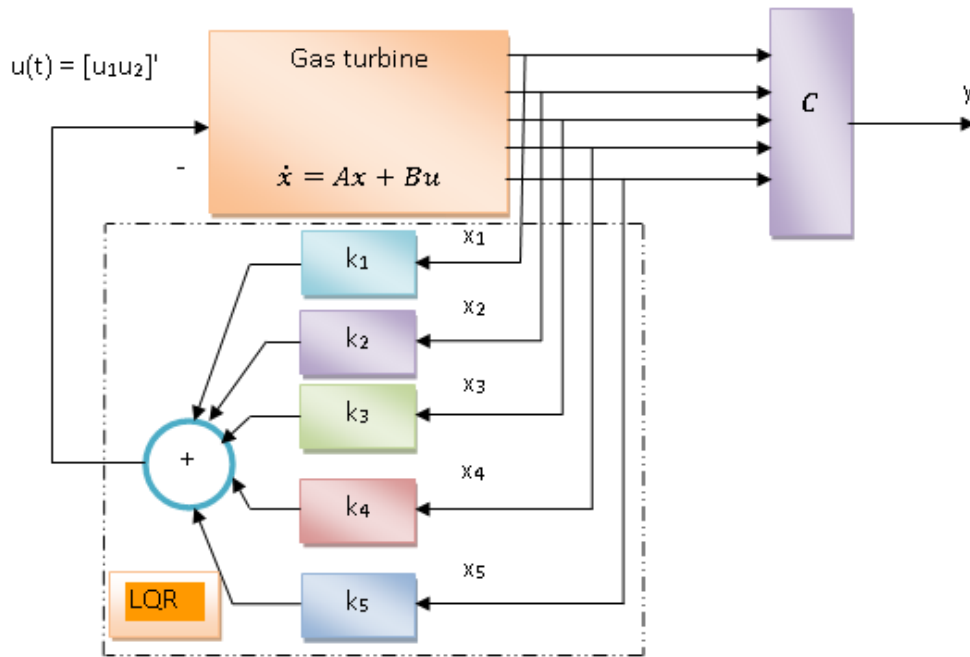

Figure 4. Blok diagram LQR with gas turbine

### 5. OBJECTIVE FUNCTION

Objective function considered as the heart of the genetic algorithm and the most difficult part of its design. For this paper, it is required to evaluate the optimum LQR controller for a gas turbine so the objective function will be selected to achieve this aim. The objective function might be created depending on the controller performance like the overshoot and rise time but it is better to combine all the transient and steady state specifications in the objective function [22]. This combination will minimize the error of the controlled system. The effectiveness of the objective function will be directly on the chromosome where each chromosome will pass into it [23]. After passing into the objective function, chromosome will be evaluated and according to this evaluation, it will be assigned by a number that represents its fitness where the bigger number is the better fitness. This fitness value then will be used to create new population. Defining the chromosome representation will be the start of the tuning procedure by the GA where each chromosome is represented in a real value form as shown in Figure 5.

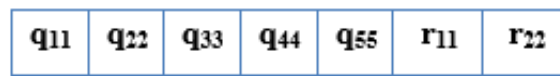

Figure 5. Chromosome definition

The state and weight matrices Q and R will be represented by seven values and these values will form the chromosome. These seven values are q11, q22, q33, q44, q55, r11 and r22. These values must be positive to be evaluated [24,25]. The next step is the calculation of the fitness function where it represents the quality of the chromosome and it can be defined in many different forms, in this paper, we will define it as Integral Time Absolute Error (ITAE)

$$ITAE = \int_0^T t|e(t)|dt = \int_0^T t|r(t) - y(t)|dt \tag{9}$$

Figure 6 shows the GA\_LQR of the gas turbine.

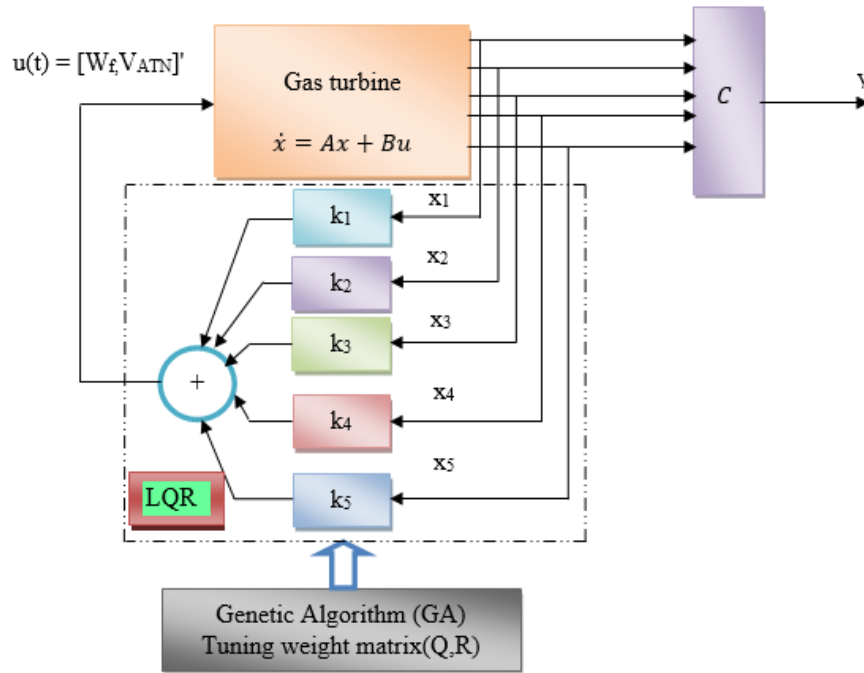

Figure 6. Block diagram of GA-LQR controller of the gas turbine

**6. SIMULATION AND RESULTS**

In this section, the result of the GA-LQR will be analyzed after been analyzed with a population size of 20. The response specifications that will be analyzed are the overshoot, where it desired to be minimum, rise time and settling time, they are desired to be fastest. Table 1 summarize the GA property with the relative values and methods since the best response will be selected depending on them.

Table 1. Parameters of GA

GA property	Value/Method
Population Size	20
Max No. of Generations	100
Fitness Function	Integral Time Absolute Error (ITAE)
Selection Method	Normalized Geometric Selection
Probability of Selection	0.05
Crossover Method	scattering
Crossover probability	0.2
Mutation Method	Uniform Mutation
Mutation Probability	0.01

The GA- LQR controller weight matrices  $Q$  and  $R$  are:

$$Q = blkdiag(q_{11}, q_{22}, q_{33}, q_{44}, q_{55}) = blkdiag(45.949, 0.251873, 45.7067, 0.367866, 0.418926)$$

$$R = blkdiag(r_{11}, r_{22}) = blkdiag(0.230221, 5.08264 \text{ e-}005)$$

The solution of the algebraic Riccati equation matrix  $P$  is

$$P = \begin{bmatrix} 1.0905 & 0.1157 & 0.0453 & 0.8704 & 0.0445 \\ 0.1157 & 1.1246 & -0.0319 & -0.0053 & 0.0001 \\ 0.0457 & -0.0319 & 0.8836 & 2.7150 & -0.0199 \\ 0.8704 & -0.0053 & 2.7150 & 14.6665 & -0.0443 \\ 0.0445 & 0.0001 & -0.0199 & -0.0443 & 0.0061 \end{bmatrix}$$

The feedback gain matrix  $K$  is giving by,  $K = R^{-1} B^T P$

$$K = \begin{bmatrix} 3.7806 & -0.0029 & 11.7930 & 63.7061 & -0.1926 \\ 874.7125 & 2.8287 & -391.7974 & -872.3987 & 120.7276 \end{bmatrix}$$

The closed loop poles (Eigen values) are shown in Table 2. The number of generation of the weight matrices  $Q$  and  $R$  elements ( $q_{11}, q_{22}, q_{33}, q_{44}, q_{55}, r_{11}$  and  $r_{22}$ ) values of GA-LQR controller are shown in Figure 7. The state vector response for GA-LQR with input vector [10] and illustrating both gas generator spool speed  $N_g$  and vehicle transmission  $T_6$  outputs are shown in Figure 8. Figure 9 shows the state vector response for GA-LQR with input vector [0 1]. The obtained results are compared with that obtained in [6] as shown in Table 3.

Table 2. Eigen values

Closed loop poles	Value
P1	-75.2227 +37.5527i
P2	-75.2227 - 37.5527i
P3	-48.5339 +40.0904i
P4	-48.5339 - 40.0904i
P5	-0.1125

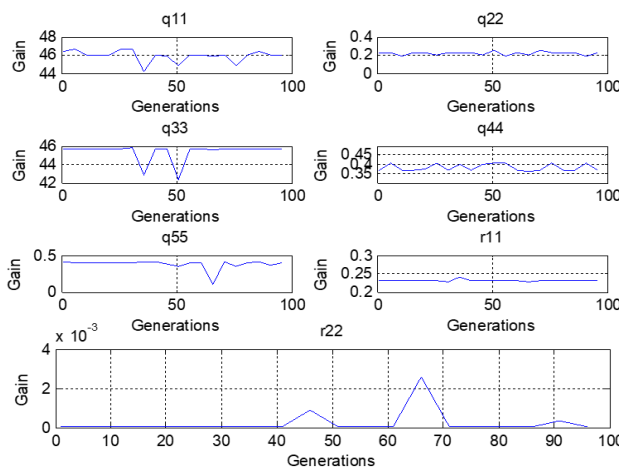

Figure 7. Number of generation of GA-LQR parameters Q and R

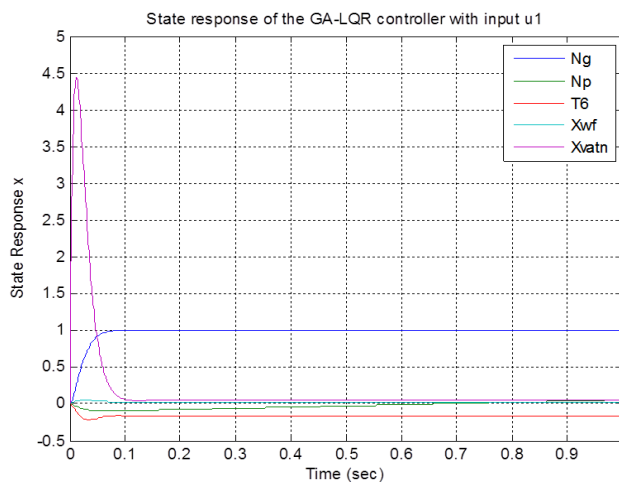

Figure 8. The state vector response of the GA- LQR with input [1 0]

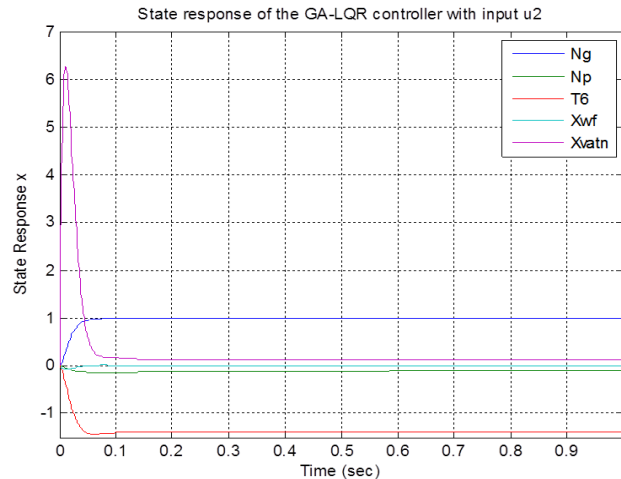

Figure 9. The state vector response of the GA- LQR with input [0 1]

Table 3. Time response specifications

Response characteristics	GA-LQR	LQR of Ref.6
Rise time	0.04	0.39
Settling time	0.07	0.686
Percentage overshoot	0.01	0.002

## 7. CONCLUSION

In conclusion, this paper presented a method that used GA technique with LQR then applied to state feedback control system. This strategy modified the state transition matrix then it used to propose the outline the difficulties at the LQR control process. These difficulties were consisting of the definition of the Q and R matrices (Weight matrices). This paper should that GA-LQR guaranteed the required system response specifications which were fasten the rise time and settling time.

## REFERENCES

- [1] Brian D.O. Anderson, John B. Moore, "Optimal Control: Linear Quadratic Methods," *Prentice-Hall International, Inc.*, Englewood Cliffs, NJ, 1989.
- [2] M. Almobaied, I. Eksin, and M. Guzelkaya, "Design of lqr controller with big bang-big crunch optimization algorithm based on time domain criteria," in *2016 24th Mediterranean Conference on Control and Automation (MED)*, pp. 1192-1197, 2016.
- [3] A. Wiese, M. Blom, C. Manzie, M. Brear, and A. Kitchener, "Model reduction and MIMO model predictive control of gas turbine systems," *Control Engineering Practice*, vol. 45, pp. 194-206, 2015.
- [4] R. G. Subramanian and V. K. Elumalai, "Robust MRAC augmented baseline LQR for tracking control of 2 DoF helicopter," *Robotics and Autonomous Systems*, vol. 86, pp. 70-77, 2016.
- [5] K. Miyamoto, J. She, D. Sato, and N. Yasuo, "Automatic determination of LQR weighting matrices for active structural control," *Engineering Structures*, vol. 174, pp. 308-321, 2018.
- [6] K. Deb, "Introduction to Genetic Algorithms for Engineering Optimization," *Part of the Studies in Fuzziness and Soft Computing book series (STUDFUZZ, volume 141)*, Springer, pp13-51, 2004.
- [7] A. I. Abdulla, J. M. Ahmed, S. M. Attya, "Genetic Algorithm (GA) Based Optimal Feedback Control Weighting Matrices Computation," *Al-Rafidain Engineering*, Vol.21, No. 5 October 2013.
- [8] S. Eshtehardiha, A. Kiyoumars, and M. Ataei, "Optimizing LQR and pole placement to control buck converter by genetic algorithm," in *2007 International Conference on Control, Automation and Systems*, pp. 2195-2200, 2007.
- [9] A. M. Hamza, M. S. Saad, H. M. Rashad, and A. Bahgat, "Gas Turbine LQR, INTEGRAL Controllers and Optimal PID Tuning by Ant Colony Optimization Comparative Study," *International Journal of Computer Science and Telecommunications*, vol. 4, pp. 35-41, 2013.
- [10] K. Ogata, "Engenharia de controle moderno, Ed," São Paulo: 4<sup>o</sup>, 2003.
- [11] Zhang, Xiao-yi. "Gas turbine controller and a method for controlling a gas turbine." U.S. Patent No. 9,422,866. 23 Aug. 2016.
- [12] Gassner, Martin Erwin, et al. "Method and system for controlling a sequential gas turbine engine," U.S. Patent Application No. 15/458,912.



- [13] P. S. Oliveira, L. S. Barros, and L. d. Q. S. Júnior, "Genetic algorithm applied to state feedback control design," in *2010 IEEE/PES Transmission and Distribution Conference and Exposition: Latin America (T&D-LA)*, pp. 480-485, 2010.
- [14] S. Sivanandam and S. Deepa, "Genetic algorithm optimization problems," in *Introduction to Genetic Algorithms*, ed: Springer, pp. 165-209, 2008.
- [15] G. Wang, M. Zhang, X. Xu, and C. Jiang, "Optimization of controller parameters based on the improved genetic algorithms," in *2006 6th World Congress on Intelligent Control and Automation*, pp. 3695-3698, 2006.
- [16] S. I. Khather, M. Almagad, and A. I. Abdullah, "Fractional order based on genetic algorithm PID controller for controlling the speed of DC motors," *International Journal of Engineering & Technology*, vol. 7, pp. 5386-5392, 2018.
- [17] N. Magaji, M. F. Hamza, and A. Dan-Isa, "Comparison of GA and LQR tuning of static VAR compensator for damping oscillations," *International Journal of Advances in Engineering & Technology*, vol. 2, p. 594, 2012.
- [18] K. H. Reddy, P. Ramanathan, and S. Ramasamy, "LQR based PI plus PD controller to control the Non-linear process," in *2016 Online International Conference on Green Engineering and Technologies (IC-GET)*, pp. 1-4, 2016.
- [19] Das, Himadry Shekhar, et al. "Fuel cell and ultracapacitor energy system control using linear quadratic regulator proportional integral controller," *Electrical Engineering* 101.2, 559-573, 2019.
- [20] M. Haraguchi and H. Hu, "Using a new discretization approach to design a delayed LQG controller," *Journal of sound and vibration*, vol. 314, pp. 558-570, 2008.
- [21] Levine, William S. "Linear quadratic regulator control," *The Control Systems Handbook*. CRC Press, 403-426, 2018.
- [22] Khatir, Samir, et al. "Genetic algorithm based objective functions comparative study for damage detection and localization in beam structures," *Journal of Physics: Conference Series*, Vol. 628. No. 1. IOP Publishing, 2015.
- [23] A. Oonsivilai and R. Oonsivilai, "A genetic algorithms programming application in natural cheese products," *Wseas Transactions on Systems*, vol. 8, pp. 44-54, 2009.
- [24] A. Oonsivilai and R. Oonsivilai, "Parameter estimation of frequency response twin-screw food extrusion process using genetic algorithms," *WSEAS TRANSACTIONS on SYSTEMS*, vol. 7, pp. 626-636, 2008.
- [25] Munje, Ravindra, Balasaheb Patre, and Akhilanand Tiwari. "State feedback control using linear quadratic regulator." *Investigation of Spatial Control Strategies with Application to Advanced Heavy Water Reactor*. Springer, Singapore, 61-77, 2018.