

Automatic traffic light controller for emergency vehicle using peripheral interface controller

Norlezh Hashim¹, Fakrulradzi Idris², Ahmad Fauzan Kadmin³, Siti Suhaila Jaapar Sidek⁴

^{1,3,4}Centre for Telecommunication Research & Innovation (CeTRI), Fakulti Teknologi Kejuruteraan (FTK),
Universiti Teknikal Malaysia Melaka (UTeM), Malaysia

²Centre for Telecommunication Research & Innovation (CeTRI), Fakulti Kejuruteraan Elektronik dan Kejuruteraan
Komputer (FKEKK), Universiti Teknikal Malaysia Melaka (UTeM), Malaysia

Article Info

Article history:

Received Aug 11, 2018

Revised Nov 20, 2018

Accepted Dec 11, 2018

Keywords:

Emergency

Peripheral Interface Controller

Radio Frequency

Receiver

Traffic Light

ABSTRACT

Traffic lights play such important role in traffic management to control the traffic on the road. Situation at traffic light area is getting worse especially in the event of emergency cases. During traffic congestion, it is difficult for emergency vehicle to cross the road which involves many junctions. This situation leads to unsafe conditions which may cause accident. An Automatic Traffic Light Controller for Emergency Vehicle is designed and developed to help emergency vehicle crossing the road at traffic light junction during emergency situation. This project used Peripheral Interface Controller (PIC) to program a priority-based traffic light controller for emergency vehicle. During emergency cases, emergency vehicle like ambulance can trigger the traffic light signal to change from red to green in order to make clearance for its path automatically. Using Radio Frequency (RF) the traffic light operation will turn back to normal when the ambulance finishes crossing the road. Result showed the design is capable to response within the range of 55 meters. This project was successfully designed, implemented and tested.

Copyright © 2019 Institute of Advanced Engineering and Science.
All rights reserved.

Corresponding Author:

Norlezh Hashim,

Centre for Telecommunication Research & Innovation (CeTRI),

Fakulti Teknologi Kejuruteraan (FTK),

Universiti Teknikal Malaysia Melaka (UTeM),

Hang Tuah Jaya, 76100 Durian Tunggal, Melaka, Malaysia.

Email: norlezh@utem.edu.my

1. INTRODUCTION

Congestion at traffic light area gives challenge in many countries. The increasing numbers of vehicles not only has a large environmental impact, but also result in loss of lives and time on the road. Besides, there will be huge losses in terms of productivity where it will affect the ability of cities to compete globally. This situation demands a better approach to handle the situation especially for emergency vehicle like ambulance. There is a need to have a system that can control the traffic light signal at junction in case of emergency.

Recently numerous researches on traffic signal control for ambulance are being carried out such as in [1]-[3]. The author in [1] have developed an intelligent traffic signal control using Radio Frequency Identification (RFID) and cloud system. The system uses an android application that connects both the traffic signal station and ambulance using cloud network. In [2], the researcher designed an Internet of Things (IoT) system for the ambulance to send patient information to the hospital and control the traffic light using Global System for Mobile (GSM) system. They used Arduino and Cayenne mobile application as well in the system designed. The paper in [3] used Global Positioning System (GPS) installed in the ambulance to find the location of the ambulance unit and RF transceiver to operate. Most of the systems proposed were outstanding and cover bigger application ranges but far from being a low cost solution since it involved more than one technology embedded into one system.

By comparing to the previous works, this paper presents the development of a low-cost system for a priority-based traffic light controller using RF modules and PIC 16F877 microcontroller. An automatic traffic light controller for emergency vehicle using PIC is a project to program a priority based traffic light controller for emergency vehicle during emergency cases where it is able to trigger the traffic light to change from red to green to make a path for its way. If the traffic light already shows green, time duration will be delayed until the emergency vehicle finishes crossing the junction. This project uses Radio Frequency (RF) for wireless signal transmission. The traffic light operation will turn back to normal when ambulance finishes crossing the road. The system designed is analyzed in terms of detectable range and results prove the system is able to work perfectly within the range of 55 meters of distance between the transmitter and the receiver.

Figure 1 shows the block diagram of the proposed system. The system consists of one transmitter and one receiver. The designed system used RF links to communicate with each other. At receiver's side, the traffic light circuit is connected to RF receiver which is also controlled by PIC16F877 microcontroller. With PIC16F877, the design was simplified where the 555 timers can be excluded in the circuit. This type of IC is used for timing of the traffic light circuit. The system used 315MHz RF transmitter and receiver module. RF transmitter and receiver module are very small in dimensions and have a wide operating voltage range from 3 volts to 12 volts. The low-cost RF transmitter can be used to transmit signal up to 100 meters but the working environment, antenna design, and supply voltage will impact the effective distance.

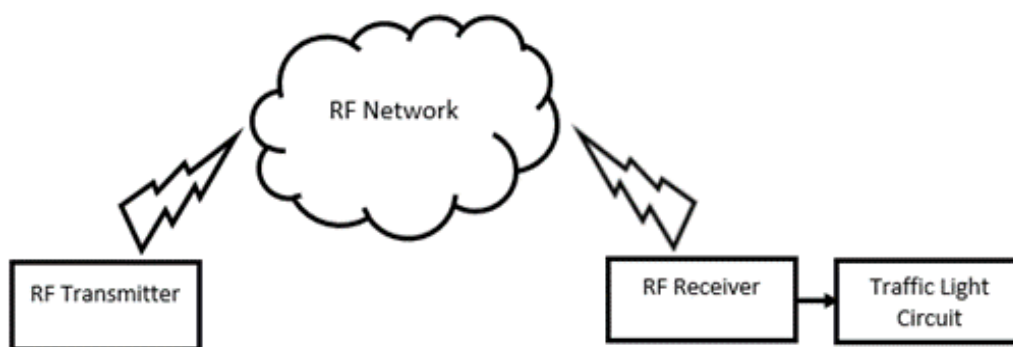

Figure 1. Overview of the proposed system

The rest of the paper is organized as follows. Section 2 explains the overview of the research method used in this paper. Result and discussions are explained in Section 3 and finally, the author concludes the findings of the paper in Section 4.

2. RESEARCH METHOD

Automatic traffic light controller for emergency vehicle consists of both software and hardware implementation. An embedded program was created using MicroCode Studio where this software was specially designed for PIC compiler. The flowchart of this project is shown in Figure 2. Once the push button is pressed, an RF signal will be transmitted to the RF receiver. This will activate the PIC to control and trigger the traffic light to turn from red to green. Some delays will be introduced if the emergency vehicle still does not manage to pass the traffic light junction where the time duration of the green light signal appearance will be longer. The traffic light system will be back to normal when the emergency vehicle successfully crosses the traffic light junction.

The schematic of the traffic light circuit is shown in Figure 3. The regulated power supply consists of LM 7805 voltage regulator and two filter capacitors. LM 7805 is a three terminals voltage regulator IC. It works actively to maintain 5 volts output independent of the output current. The different between the output voltage and input voltage is converted to heat. The higher the input voltage, the hotter the LM7805 will be. LM7805 will need a heat sink if the input voltage is high. The maximum reading for the output voltage is very small around 4.8–4.9 volts, so the heat sink is not needed. The transmitter and receiver schematic circuits are shown in Figure 4 and Figure 5 respectively.

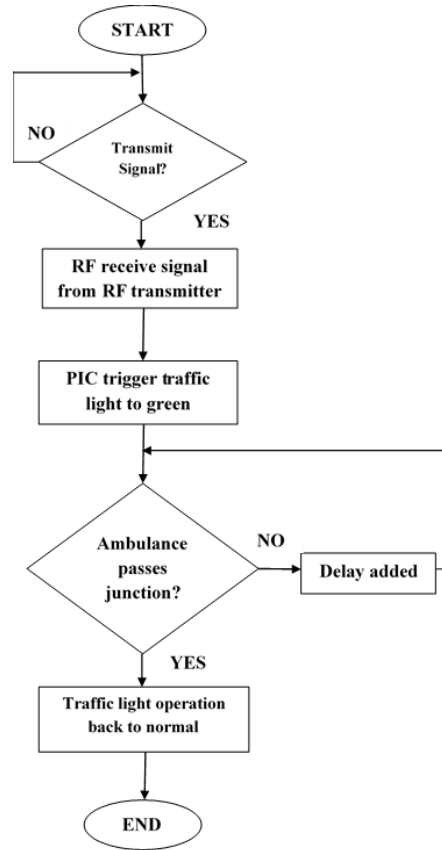

Figure 2. Flowchart of the system

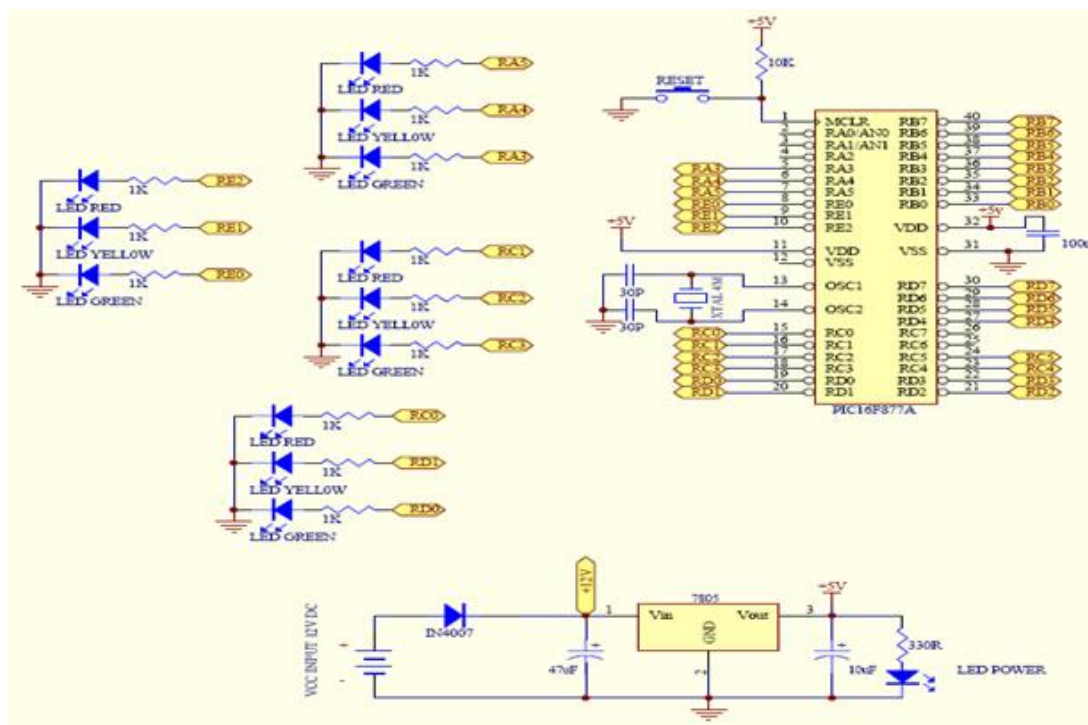

Figure 3. Schematic of traffic light circuit

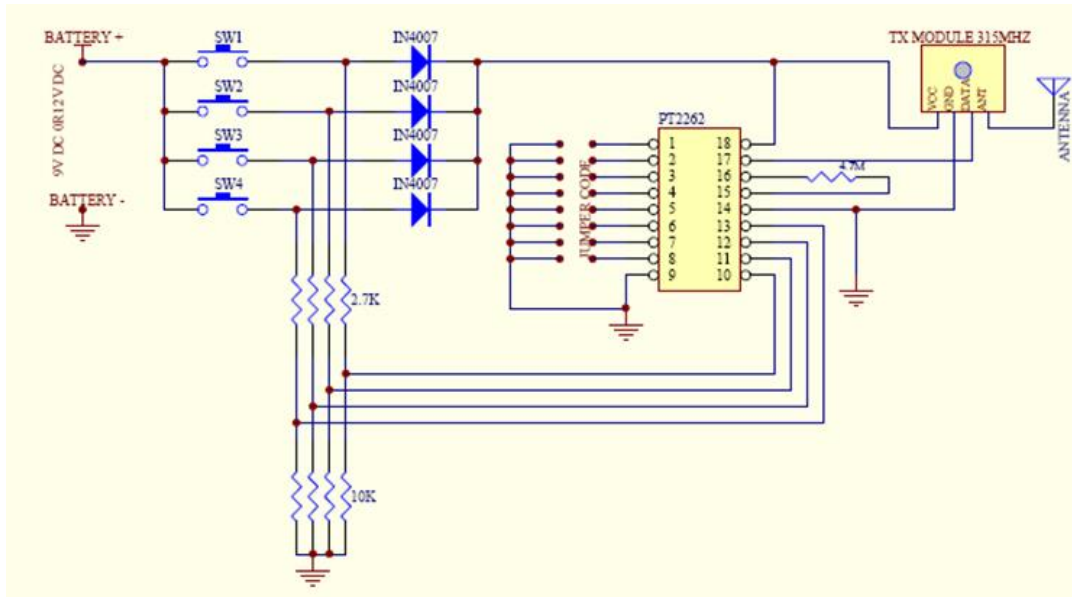

Figure 4. Transmitter schematic circuit

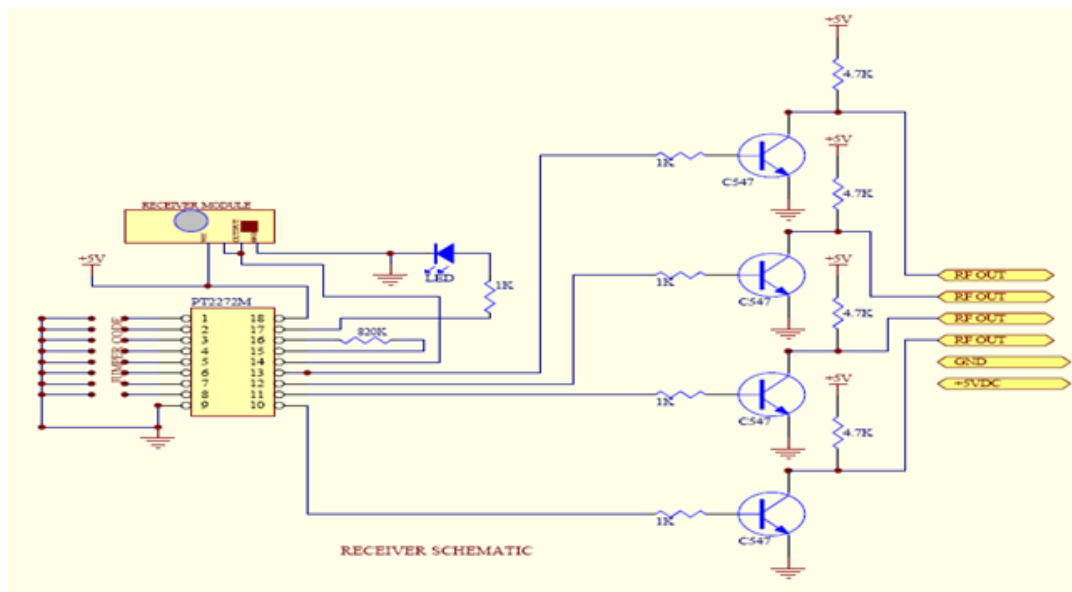

Figure 5. Receiver schematic circuit

3. RESULTS AND ANALYSIS

In this section, the prototype of automatic traffic light controller for emergency vehicle is presented and the performance analysis of the designed system for different distances is shown. Figure 6 shows the traffic light circuit on Printed Circuit Board (PCB). There are four push buttons at the transmitter circuit board. Each button can control the set of LEDs on each junction as depicted. The microcontroller is the brain for this project and is used to initiate the traffic signals at the intersections on road. Three Light Emitting Diodes (LEDs) were placed at each junction to represent red, green and yellow light. The transmitter and receiver circuit boards are shown in Figure 7 and Figure 8 respectively. RF modules are used to send and receive radio signals between the two circuits.

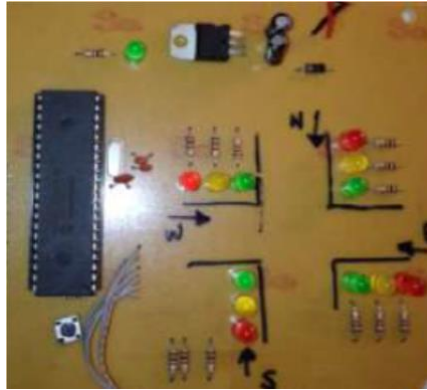

Figure 6. Traffic light model

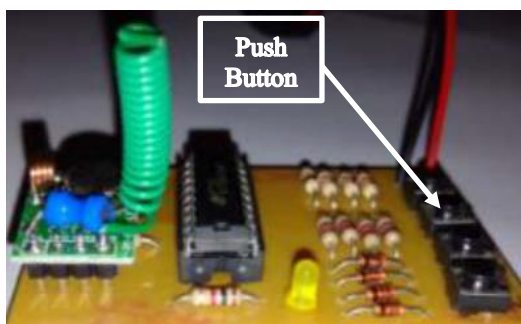

Figure 7. Transmitter schematic circuit



Figure 8. Receiver schematic circuit

3.1. Experiment setup

An experiment was conducted at outdoor area to test the performance of the system. Figure 9 shows the experiment setup for data analysis. The location of the RF transmitter was varied incrementally until the RF receiver was not able to detect the RF transmitter.

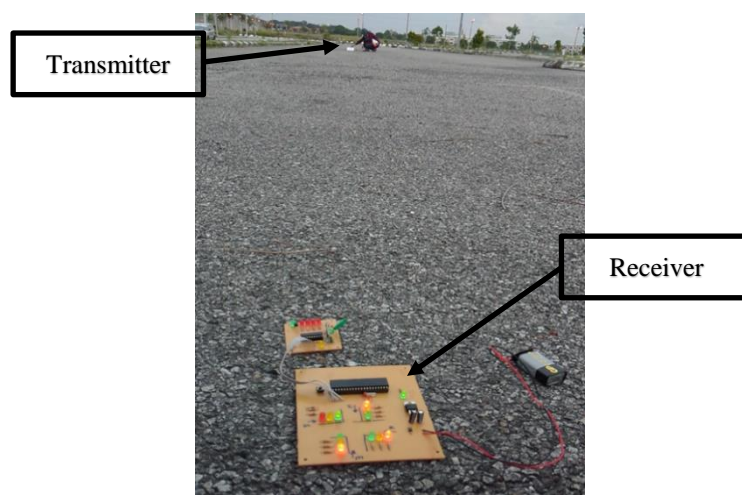

Figure 9. Experiment setup

Figure 10 shows the time taken for the traffic light to change from red to green once triggered versus different distances. Stop watch was used to measure the time differences and measuring tape was used to record

the distances. Based on the graph, the delays increase with increasing distance. The same pattern of results was observed in Wireless Fidelity (WiFi) based system [4]. The RF receiver is able to detect the signals up to 55 meters. The connection is lost after 55 meters if the distance between the RF transmitter and the RF receiver is more than 55 meters due to RF limitation range. Three seconds delay was added into the program to represent the time taken to switch the traffic light from red to green. The time at specific distance is measured once the pushbutton at the RF transmitter is pushed until the red LED at the traffic light circuit board changes to green.

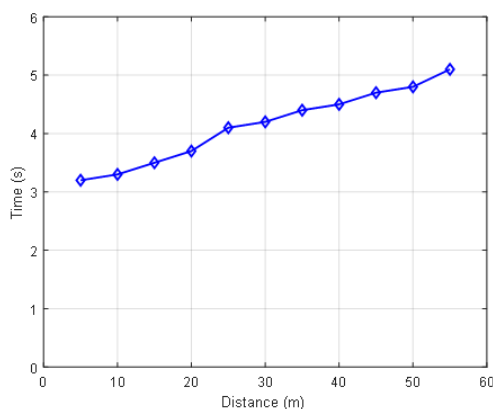

Figure 10. System performance

4. CONCLUSION

In this paper, we have successfully designed and analyzed an automatic traffic light controller for emergency vehicle. Peripheral interface controller (PIC) is used as the micro controller and the system can be operated wirelessly using radio frequency (RF) during emergency cases. In future, different type of wireless technology such as LoRa and multi hop network [7], [8] could be replaced in the existing system to cater for longer traffic jam. Furthermore, the 9 volts battery used to operate the system could be replaced with solar powered battery to increase the efficiency of the design. Different microcontroller [9] could also be introduced to save programming processing time in the future.

ACKNOWLEDGEMENTS

We would like to thank Universiti Teknikal Malaysia Melaka (UTeM) for sponsoring this research under Short Term Research Grant PJP/2017/FTK-CACT/S01566

REFERENCES

- [1] B. Janani Saradha, G. Vijayshri, and T. Subha, "Intelligent Traffic Signal Control System for Ambulance using RFID and Cloud," *IEEE Proceedings on Computing and Communications Technologies (ICCCCT)*, pp. 90-96, 11 Jul 2017.
- [2] S. N. Sivaraj, K. Vigneshwaran, S. Vigneshwaran, and M. Vishnu Priyan, "IoT Ambulance with Automatic Traffic Light Control," *SSRG International Journal of Industrial Engineering (ICRTECITA)*, pp. 12-18, Mar 2017.
- [3] K. Sangeetha, P. Archana, M. Ramya, and P. Ramya, "Automatic Ambulance Rescue with Intelligent Traffic Light System," *IOSR Journal of Engineering (IOSRJEN)*, vol. 4, pp. 53-57, Feb 2014.
- [4] N. Hashim, N. F. A. M. Azmi, F. Idris and N. Rahim, "Smartphone Activated Door Lock using WiFi," *ARNP Journal of Engineering and Applied Sciences*, vol. 11(5), pp. 3309-3312, Mar 2016.
- [5] S. Kapoor, P. Gupta, P. Sharma, and P. N. Singh, "Intelligent Ambulance with Automatic Traffic Control," *International Research Journal of Engineering and Technology (IRJET)*, vol. 4, pp. 1264-1266, Apr 2017.
- [6] N. Hashim, M. A. H. A. Razak, F. Idris, "Home Security System using Zigbee," *Jurnal Teknologi (Sciences & Engineering)*, vol. 74(10), pp. 29-34, 15 Mar 2015.
- [7] F. Idris and N. Hashim, "Deployment and Evaluation of a Multi-Hop Wireless Network," *International Journal of Computer Trends and Technology (IJCTT)*, vol. 5(2), pp. 80-83, Nov 2013.
- [8] F. Rahmat, F. Idris, M. Azri, V. Kanathasan, N. Sarimin and M. H. Mohamad, "Performance Analysis of VoIP in Multi-hop Wireless Network," *2012 IEEE Asia-Pacific Conference on Applied Electromagnetics (APACE)*, pp. 51-55, 2012.
- [9] Kadmin A. F., Jidin A.Z., Bakar A., Aziz K.A. and Rashid W.A., "Wireless Voice-Based Wheelchair Controller System," *Journal of Telecommunication, Electronic and Computer Engineering (JTEC)*, vol. 8(7), pp. 117-122, 2016.

BIBLIOGRAPHY OF AUTHORS

Norlezh Hashim obtained her first degree in 2006 from University of Malaya and her master degree from Universiti Teknologi Malaysia in 2014. In the past, she worked in Panasonic as an R&D engineer. Currently she is serving UTeM as a lecturer in Faculty of Engineering Technology. Her current publications and interest research areas are based on wireless communication and LoRa.



Fakrulradzi Idris received the B.Eng. and the M.Eng. Degrees from Universiti Teknologi Malaysia in 2007 and 2008 respectively. He is currently pursuing the Ph.D. degree with the School of Electrical and Electronic Engineering, The University of Manchester, U.K. His research interests include Device-to-Device communications, non-orthogonal multiple access and 5G networks.



Ahmad Fauzan B. Kadmin CEng. P.Tech. currently attached with UTeM as a researcher, Ahmad Fauzan B. Kadmin CEng. P.Tech. has over 14 years of experience in electronic & computer engineering field with technical expert in R&D engineering, computer vision & medical electronics. He Graduated with a Bachelor Degree in Electronics Engineering from Universiti Sains Malaysia and Master Degree in Computer & Communication Engineering from Universiti Kebangsaan Malaysia. Previously, he worked with Megasteel Sdn. Bhd., Samsung SDI(M) Sdn. Bhd. and Agensi Angkasa Negara. He published several technical and engineering paperworks in image processing and medical electronics.