

Flood disaster indicator of water level monitoring system

Wan Haszerila Wan Hassan, Aiman Zakwan Jidin, Siti Asma Che Aziz, Norain Rahim

Centre for Telecommunication Research and Innovation, Fakulti Teknologi Kejuruteraan Elektrik Elektronik (FTKKEE),
Universiti Teknikal Malaysia Melaka (UTeM), Malaysia

Article Info

Article history:

Received Aug 11, 2018

Revised Nov 20, 2018

Accepted Dec 11, 2018

Keywords:

Arduino board

Float switch sensors

Flood

GSM network

System units

ABSTRACT

The early warning systems for flood management have been developed rapidly with the growth of technologies. These system help to alert people early with the used of Short Message Service (SMS) via Global System for Mobile Communications (GSM). This paper presents a simple, portable and low cost of early warning system using Arduino board, which is used to control the whole system and GSM shields to send the data. System has been designed and implemented based on two components which is hardware and software. The model determines the water level using float switch sensors, then it analyzes the collected data and determine the type of danger present. The detected level is translated into an alert message and sent to the user. The GSM network is used to connect the overall system units via SMS.

Copyright © 2019 Institute of Advanced Engineering and Science.
All rights reserved.

Corresponding Author:

Wan Haszerila Wan Hassan,
Centre for Telecommunication Research and Innovation,
Fakulti Teknologi Kejuruteraan Elektrik Elektronik (FTKKEE),
Universiti Teknikal Malaysia Melaka (UTeM),
Hang Tuah Jaya, 76100 Durian Tunggal, Melaka, Malaysia.
Email: haszerila@utem.edu.my

1. INTRODUCTION

Flood is commonly occurred natural disaster around the world. It will cause unsafely manner to human by causing death, injury, damages and great property losses. In Malaysia, flood is considered as norm disaster that happen especially during monsoon season at the end of the year. As Malaysia located near the equator, the most worst climatic related natural disasters are monsoonal flood. Communities living around the low-laying area are facing high risk of losses caused by flooding. This natural disaster is inevitable but with advance warning system and early response, the destruction can be minimized. Forecasting and warning systems is one of the methods that could significantly mitigate the impact of losses. Alerting or warning to notify the public about the upcoming disaster in the early stages is very important as safety measures can be taken to prevent unwanted mishaps.

The early warning system must be able to provide timely warning of imminent dangers, which gives the local authorities time to prepare for effective response. There is a lack of concern in the substantial of an early warning system eventhough the technologies are widely available. Warning might fail to reach the local authorities and sometimes it may not be understood due to ineffective or unsuitable alert tools of communication channels. However, with the advance of technologies produce simple and low cost tools that can be used to solve such problems.

This paper focuses on flood disaster monitoring system to help local authority to provide more systematic solution. The designed system can detect the floods and give continuous alert or information. The information of water level can be detected by the sensors. The goal of the system is to alert the community, so that safety precautions can be taken to protect their life and properties. The developed system utilizes GSM and SMS to transmit data from sensors to the respective users through their mobile phone. By using GSM module, GSM network can be used since it is much more accountable during flood season. An Arduino UNO

board has been used as the controlling device. This board is a low cost microcontroller, needs simple programming and can be integrated with other devices via the input-output interfaces.

2. BASIC STRUCTURE AND WORKING PRINCIPLE

Basic structure of flood monitoring system is illustrated in Figure 1. The block diagram shows the system consist of float switch sensors, an Arduino Uno controller, GSM module and mobile phone.

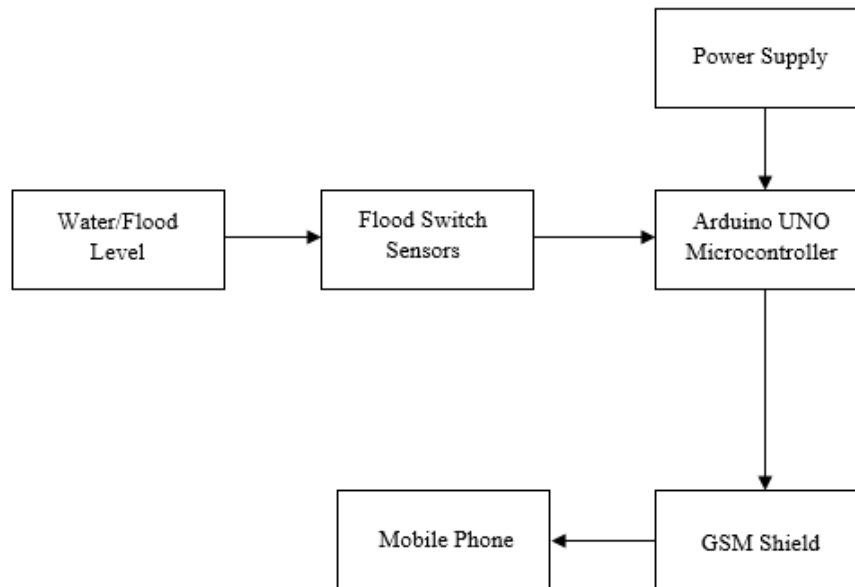

Figure 1. System structure of flood monitoring system

Three float switch sensors are used to differentiate the escalation level. The data send by the sensors are handled by the Arduino Uno controller. The Arduino Uno controller has been program for different input and send different output through transmission pin. Commands are send using C compiler program with relevant (Attention) AT commands.

The transmitted output from the Arduino Uno controller is conveyed through to GSM module. Then, SMS alarm send to the respective user. User receives different SMS depending on the level of sensors detection. GSM network is being exploited to convey data to the user via SMS alarm. SMS via GSM network has been proven to be reliable due to its works on a different band and can be sent or received although the phone lines are congested. It also has the advantage of sending data to multiple users (SIMO) [1].

The working principle of the system is based on sensor detection shown in Table 1. The model of the system contains of three sensors but with five conditions. It start with “SAFE CONDITION (No flood detection)” if the three sensors at the lowest position of all float switch sensors. Thus, the message send through GSM and display on the LCD. When the level one sensor receives a signal which means the water has increased more than the threshold, a message “ALERT (Early detection and alert)” send to the mobile victims or authorities and display as “Alert! (Level 1)” on the LCD. Level two sensor would be positioned higher than level one sensor. The level two sensor detects the medium level of water with a message “MODERATE RISK LEVEL (Respond to alert)” and display as “Moderate risk!! (Level 2)” on the LCD.

The highest positioned sensor which is level three detect the high level of water with a message “HIGH RISK LEVEL (Rescue activities)” which inform the people the dangers situation of flood and display “High risk!!! (Level 3)”. Lastly, the “TECHNICAL PROBLEM” send through GSM and display on the LCD if the sensors have any problem such as malfunction or stuck to wastage. Two techniques are used to send the data via SMS to the authorities and the public flood victims. The first technique use GSM to send the information to publics. While, the second technique use GSM send the information to the authorities or mobile company, which has ability to spread the information to all people who live in the flooding area.

Table 1. SMS Contents Based On Conditions

Flood Switch Sensor			Conditions	SMS Contents
Sensor (1)	Sensor (2)	Sensor (3)		
0	0	0	SAFE CONDITION (RISK-FREE)	SAFE CONDITION (No flood detection)
0	0	1	TECHNICAL PROBLEM	TECHNICAL PROBLEM (Check the sensors)
0	1	0	TECHNICAL PROBLEM	TECHNICAL PROBLEM (Check the sensors)
0	1	1	TECHNICAL PROBLEM	TECHNICAL PROBLEM (Check the sensors)
1	0	0	ALERT! (LEVEL 1)	ALERT LEVEL (Early detection and alert)
1	0	1	TECHNICAL PROBLEM	TECHNICAL PROBLEM (Check the sensors)
1	1	0	MODERATE RISK!! (LEVEL 2)	MODERATE RISK LEVEL (Respond to alert)
1	1	1	HIGH RISK!!! (LEVEL 3)	HIGH RISK LEVEL (Rescue activities)

3. HARDWARE IMPLEMENTATION

In development of the flood monitoring device, the following components are used: Arduino Uno microcontroller board based on the ATmega328, GSM modem, float switch sensors (RSF50 Series) and Liquid crystal display (M1632 LCD) screen. The hardware design circuit is shown in Figure 2.

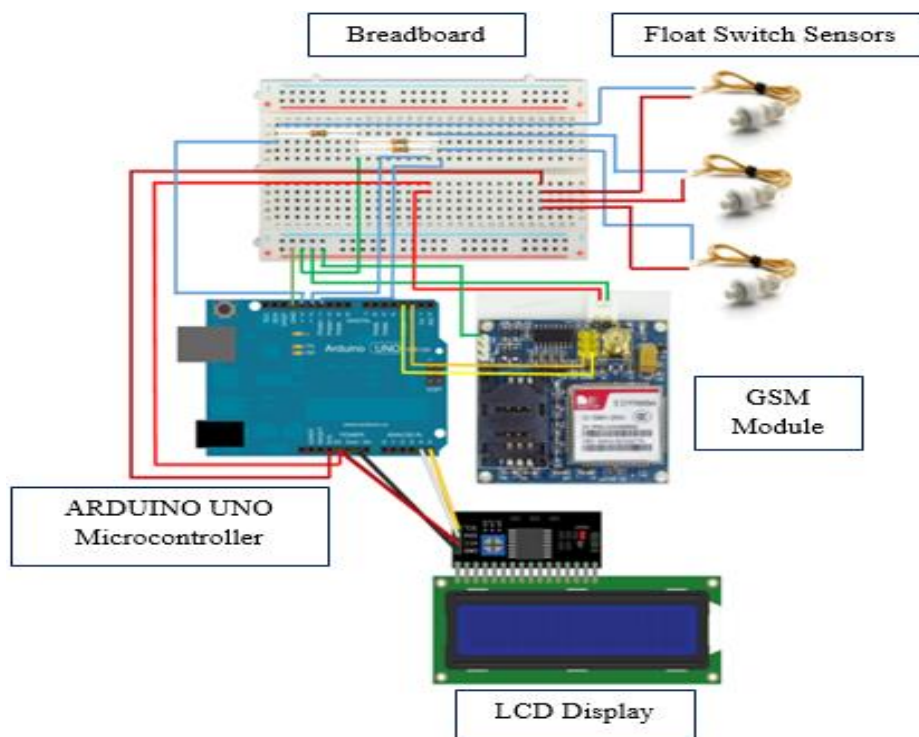

Figure 2. Hardware design circuit

The three float switch sensors are located at the selected areas determined by the user. As the requirements, these sensors are used to measure water level either in safe condition or in high risk zone. The designed system able to identify five different conditions. An electric pulse is generated when detecting the presence of water. The operation starts with data collection from float switch sensors and then pass to the Arduino Uno microcontroller. The microcontroller analyzes the real time data and compare to the pre-determined value. The outputs are presented in SMS and also displayed on the LCD screen. The programming

part for microcontroller is using the Integrated Development Environment (IDE), which written in Java, is based on the wiring project, an open source programming environment.

Figure 3 shows the prototype of flood monitoring system. The prototype of flood monitoring system consists of two part which are receiver and transmitter. The transmitter part function to transmit and display data from the sensors. Meanwhile, the receiver part receives data from the transmitter part and send to the device that supports the local Telco Sim. All the monitoring process is conducted by placing the prototype in the water tank. The height of water in the water tank with the sensors must be calibrated in order to obtain more accurate results. The monitoring process is conducted at different time and weather to test the prototype efficiency in all condition.

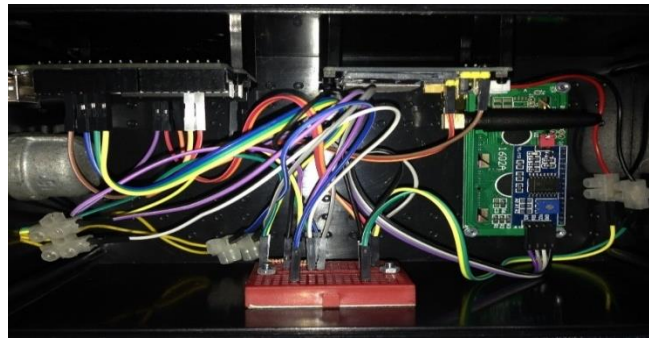

Figure 3. Prototype of flood monitoring system

4. EXPERIMENTAL RESULT

The data collection is collected through SMS input. The data is manually interpreted by the user or local authority to declare the situation according with float switch sensor output. Figure 5 is example of data obtained through SMS. The sequence has been programmed to be in the state as described in block diagram as in Figure 4.

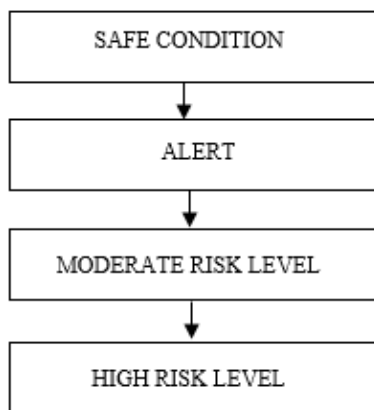

Figure 4. Block diagram of SMS to users

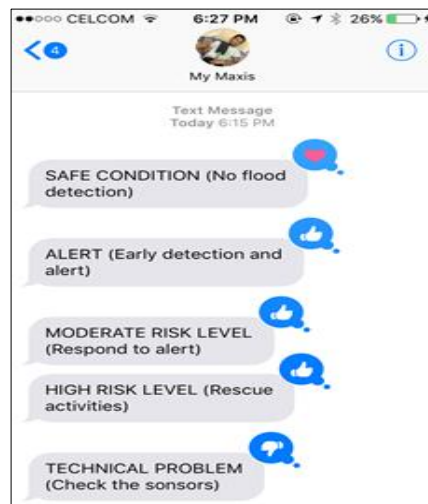

Figure 5. SMS contents to users

Instead of output is presented in SMS form, the data collected also displayed on LCD screen in front panel of float switch sensor to conduct error checking and calibration. Figure 6 shows the outputs display on LCD screen. Figure 7 shows the data collection through serial monitor in IDE software. All data are interpreted directly if the sensor detecting the water level. The data of all condition are collected into one page displayed.

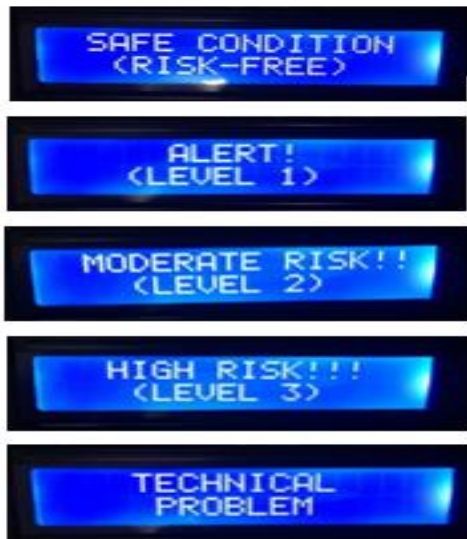

Figure 6. Data collection displayed on LCD screen

```

COM5 (Arduino/Genuino Uno)
|
GSM initialized
SENDING
Message:
SAFE CONDITION (No flood detection)
SEND MESSAGE COMPLETED!
SENDING
Message:
ALERT (Early detection and alert)
SEND MESSAGE COMPLETED!
SENDING
Message:
MODERATE RISK LEVEL (Respond to alert)
SEND MESSAGE COMPLETED!
SENDING
Message:
HIGH RISK LEVEL (Rescue activities)
SEND MESSAGE COMPLETED!
SENDING
Message:
TECHNICAL PROBLEM (Check the sensors)
SEND MESSAGE COMPLETED!

```

Figure 7. Serial monitor in IDE software

5. FUTURE WORKS

For future improvement, the system can be upgraded with addition of the component in GUI with more button functions. The GSM modem for transmitting the data to the control center can be used as it is easily connected to the computer. Additionally, the float switch sensors can be replaced with the wireless sensor as sensors are essential components in this framework. Exact and precise discovery of water level will enhance the information gathering framework for the observing station. The collected data of flood alert information can also be displayed on LED for road street clients and for security reasons.

A conceivable method for power supply for the sensors and brought together the control unit is by means of solar cells. The flood disaster indicator through GSM using SMS will be easy to install and maintained if it is powered by solar cells. The utilization of sunlight based vitality will likewise give less expensive wellspring of energy to the whole framework to work particularly if the framework is set at the remote area. For sustainability the circuits and control unit should be designed to consume minimum power during operation.

6. CONCLUSION

Effective early floods warning system can be beneficial to the community and act as a precautionary action for the victims in preventing loss of lives, trauma from disaster and property from damage. SMS is an effective alert communication tools that can disseminate the information to floods victim in a particular area. It is best for this system to add element of data mining and artificial intelligent, which could assist in analyzing water level data, thus produce extensive graphs for better analysis. This outcome will help in future prediction of water level behavior. From the finding made, the objectives of the project are successfully achieved, where the circuit completely functioned. The data is finally been sent via GSM mobile, where it act as a modem for the system. All three float switch sensors are detecting all the water level that consist of alert level, moderate risk level and high risk level. Finally, data from input sensor and Arduino Uno microcontroller reached at the control center.

ACKNOWLEDGEMENTS

We wish to acknowledge our honorable university, Universiti Teknikal Malaysia Melaka (UTeM). Special appreciation and gratitude to especially the Malaysia Ministry of Higher Education for the financial funding under Grant No. FRGS/1/2015/TK04/FTK/03/F00285 and providing instrumentation devices support for completing this project.

REFERENCES

- [1] Z. Odli, *et al.*, "Development of Portable Water Level Sensor for Flood Management System," *Journal of Engineering and Applied Sciences*, vol. 11, no. 9, 2016.
- [2] O. Intharasombat and P. Khoenkaw, "A Low-cost Flash Flood Monitoring System," *7th International Conference on Information Technology and Electrical Engineering (ICITEE)*, Chiang Mai, pp. 476-479, 2015.
- [3] M. Helmi and B. I. N. Ali, "Early Warning System Using Radio Frequency," *Thesis, Universiti Teknologi Malaysia*, 2014.
- [4] N. M. Z. Hashim and N. B. Hamdan, "Flood Detector Emergency Warning System," *International Journal of Engineering and Computer Science (IJECS)*, vol. 2, no. 8, pp. 2332–2336, 2013.
- [5] E. Kuantama, *et al.*, "Early flood alerts using Short Message Service (SMS)," *Proceedings of the 2012 International Conference on System Engineering and Technology, ICSET 2012*, pp.3–7, 2012.
- [6] A. K. Jha, *et al.*, "Cities and Flooding: A Guide to Integrated Urban Flood Risk Management for the 21st Century," *Urban Development Series: World Bank Publications*, pp. 50-130, 2012.
- [7] D. Han, "Flood Risk Assessment and Management," *Uk: Bentham Science Publishers*, pp. 23-135, 2011.
- [8] W.A.H.W.M Asmara and N.H.A Aziz, "SMS flood alert system," *Proceedings - 2011 IEEE Control and System Graduate Research Colloquium, ICSGRC*, pp. 18–22, 2011.
- [9] I. A. Aziz, *et al.*, "Cooperative flood detection using GSM via SMS," *International Symposium on Information Technology*, Kuala Lumpur, pp. 1-7, 2008.
- [10] M. Mouly and M.-B. Pautet, "The GSM system for mobile communications," *The University of Michigan: Cell & Sys*, pp. 1-125, 1992.

BIOGRAPHIES OF AUTHORS

Wan Haszerila Wan Hassan holds a Master of Electrical, Electronic & Telecommunication Engineering from UTM and Bachelor of Electrical & Electronic Engineering from UTM. She has previous working experience in semiconductor industry at Infineon Technologies Malaysia. She joins Universiti Teknikal Malaysia Melaka (UTeM) as lecturer on 2014. Her research area includes Photonics, Optical Communication and Wireless Communication.



Aiman Zakwan Jidin obtained his MEng in Electronic and Microelectronic System Engineering from ESIEE Engineering Paris France in 2011. He has 2 years of working experience in designing digital IC and digital system in FPGA at Altera Corporation Malaysia, before joining Universiti Teknikal Malaysia Melaka (UTeM) as lecturer and researcher, in Electronics and Computer Engineering. His research interests include FPGA Design and Digital System Design.



Siti Asma Binti Che Aziz earned her Master of Electrical, Electronic & System Engineering and Bachelor of Electrical, Electronic & System Engineering from UKM. Before joining Universiti Teknikal Malaysia Melaka (UTeM), she has about 4 years working experience with Telekom Malaysia Berhad. Her research interest include Optical Communication, Wireless Communication.



Norain Binti Rahim has Master of Electrical Microelectronics & Computer System Engineering from UTM and Bachelor of Computer Engineering from UniMAP. She conducts research on Microprocessor and Embedded Systems.