

Design and control technique for single phase bipolar H-bridge inverter connected to the grid

Linda Hassaine, Mohamed Rida Bengourina

Centre de Développement des Energies Renouvelables, CDER, Algeria

Article Info

Article history:

Received Oct 9, 2018

Revised Dec 2, 2019

Accepted Dec 10, 2019

Keywords:

Bipolar PWM

Control

Grid connected photovoltaic system

H-Bridge inverter

ABSTRACT

The power quality injected into the grid and the performance of the converter system depend on the quality of the inverter current control. This paper proposes a design and control technique for a photovoltaic inverter connected to the grid based on the digital pulse-width modulation (DSPWM) which can synchronise a sinusoidal output current with a grid voltage and control a power factor. The current injected must be sinusoidal with reduced harmonic distortion. The connected PV system is based on H-Bridge inverter controlled by bipolar PWM Switching. The current control technique and functional structure of this system are presented and simulated. Detailed analysis, Simulations results of output voltage and current waveform demonstrate the contribution of this approach to determinate the suitable control of the system. A digital design of a generator PWM using VHDL is proposed and implemented on a Xilinx FPGA and it has been validated with experimental results. As a result, the proposed inverter implementation is simple, and it becomes an attractive solution for low power grid connected applications.

Copyright © 2020 Institute of Advanced Engineering and Science.
All rights reserved.

Corresponding Author:

Linda Hassaine,

Centre de Développement des Energies Renouvelables, CDER,
BP62 Route de l'observatoire 16340 Bouzaréah, Algiers, Algeria.

Email: l.hassaine@cder.dz

1. INTRODUCTION

The market for photovoltaic systems has a very high increase rate around 30 to 40% per year. This exceptional increase, is mainly due to photovoltaic system (PV) connected to the grid and results by technological innovation and lower costs of PV modules but also significant efforts in research and development in the field of power electronics. In PV systems connected to the grid, the inverter which converts the output direct current (DC) of the solar modules to the alternate current (AC) is receiving increased interest in order to generate power to utility. In fact, the technical performance and reliability of inverters used in photovoltaic systems connected to the grid are parameters that can greatly vary the annual electricity power and thus the financial viability of a system. One important part of the system connected to the grid is its control. The control tasks can be divided into two major parts [1-11].

1. Input-side controller, with the main property to extract the maximum power from the input source, PV modules. Protection of the input-side converter is also considered in this controller.
2. Grid-side controller, which can have the following tasks: control of active and reactive power generated to the grid; control of dc-link voltage; ensure high quality of the injected power; grid synchronization.

The DC-AC converter injects sinusoidal current into the grid, controlling the power factor. Some key points have been identified in which significant improvements can be carried out in the design and implementation of the inverters connected to the grid, as: low total harmonic distortion, elimination of the DC component injected into the connected grid, control both the active and reactive power and the digital implementation of the control [2, 3]. The control strategy applied to the grid-side converter consists mainly

of two cascaded loops. Usually, there is a fast internal current loop, which regulates the grid current, and an external voltage loop, which controls the dc-link voltage. The current loop is responsible for power quality issues and current protection; thus, harmonic compensation and dynamics are the important properties of the current controller. The dc-link voltage controller is designed for balancing the power flow in the system. Usually, the design of this controller aims for system stability having slow dynamics. The aim of external controller is the dynamic system stability and the optimal regulation; so this voltage loop is designed for a low stability time 5 to 20 times higher than the internal current loop. The internal and external loops can be considered decoupling, therefore the transfer function of current control loop is not considered when it is designed the voltage controller. In some works, the control of grid-side controller is based on a dc-link voltage loop cascaded with an inner power loop instead of a current loop. In this way, the current injected into the grid is indirectly controlled [11-15]. The generated pulse width modulation (PWM) is able to reduce the magnitude of the low order of harmonic components present in the input AC supply.

Digital implementation provides improvements over their analog counterparts. They are immune to noise and are less susceptible to voltage and temperature changes. Hence, an interest to digital implementation has been noted. Using FPGA's will provide flexibility and simplicity in modifying the designed circuit without altering the hardware and rapid prototyping [16-23]. The objective of this work is to improve the output power quality of grid connected PV inverters and lower equipment costs for these systems. This will be achieved through H-bridge inverter and control. In this paper, description of the control technique is presented and implemented in FPGA. The functional structure of this system, has been validate with simulations and experimental results. The prototype has been realized.

2. CURRENT CONTROL TECHNIQUE

The power quality injected into the grid and the performance of the converter system depend on the quality of the inverter current control, Figure 1. Generally, for lower installation of photovoltaic systems connected to the grid, pulse width modulation (PWM) is a widely used technique for controlling the voltage source inverters injects currents into the grid. The current injected must be sinusoidal with reduced harmonic distortion. Moreover, a sinusoidal input current should be achieved with a total harmonic distortion (THD) below 5% as suggests the international standard IEEE std 929-2000 [3] Table 1. Most of the control strategies were made to control the current injected into the grid and power factor.

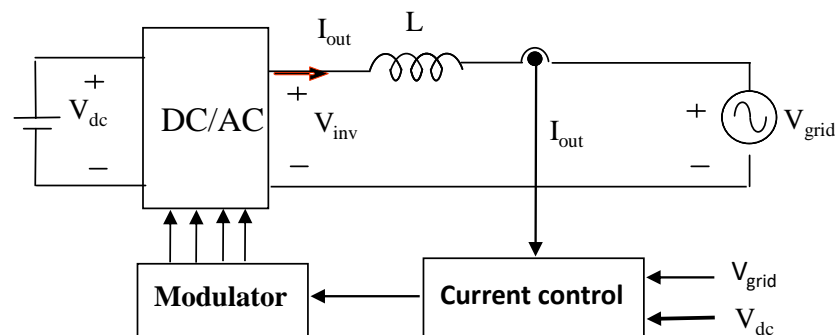

Figure1. Inverter current control

Table 1. Harmonics distortion order

ODD HARMONIC	DISTORTION LIMIT
3 rd through 9 th	Less than 4.0%
11 th through 15 th	Less than 2.0%
17 th through 21 st	Less than 1.5%
23 rd through 33 rd	Less than 0.6 %

The main objective of the current controller is to ensure that the output inverter current follow carefully the reference current independently of the selected control technique. The current controller of power converters can be a closed loop PWM, such as Hysteresis Current Control, linear PWM, predictive controllers, optimized controllers, neural network and fuzzy logic controller systems [4]. In comparison to

open loop. PWM techniques, have several considerable advantages, such as extremely good dynamics, instantaneous peak current control and prevention of overload and pulse dropping problems [11]. Hysteresis current control have a good stability, which is provided by maintaining current errors within the hysteresis band. Figure 2 shows the different PWM control current methods. Linear current control uses PWM modulation. In this control, as shown in Figure 3, the modulating signal is compared with the triangular carrier coming from the output of a linear regulator, usually a proportional-integral PI regulator. In most situations a sinusoidal output voltage is required. This may be achieved by modulating the pulse width of each bridge leg using a sine wave reference. There are two common switching strategies, which are applied to the H-Bridge inverter; these are Bipolar and Unipolar PWM switching.

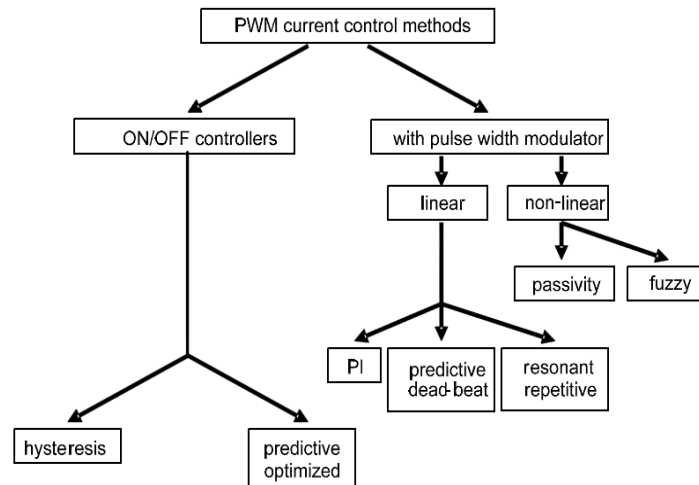

Figure 2. Current control methods

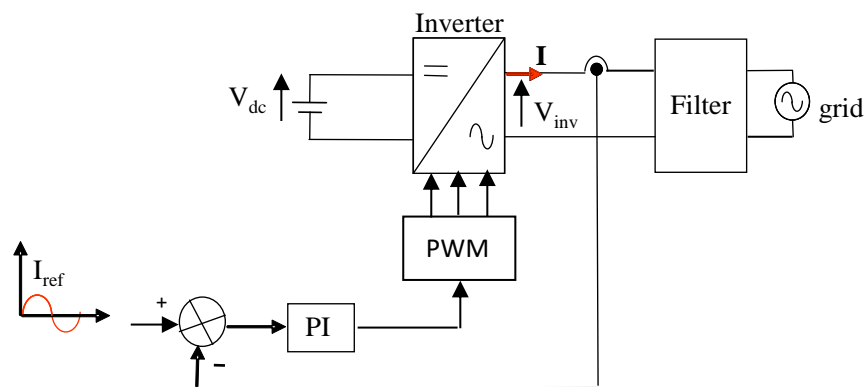

Figure 3. Linear current control

3. PV SYSTEM CONNECTED TO THE GRID

Figure 4 show an electrical scheme of the single phase H-Bridge inverter connected to the grid. The main specification of the inverter connected to the grid is that the current must be injected from a PV panel with a power factor within a certain range [3]. DC/DC converter is employed to boost the PV-array voltage to an appropriate level based on the magnitude of utility voltage, while the controller of the DC-DC converter is designed to operate as a maximum power point tracker (MPPT) that increases the economical feasibility of the PV system. A large variety of MPP tracking algorithms exists: look-up table, perturbation and observation (P&O), incremental conductance etc. For the MPPT controller, the perturb-and-observe method is adopted owing to its simple structure and the fact that it requires fewer measured parameters. This strategy is implemented to operate under rapidly changing solar radiation in a power PV grid connected System [24-25].

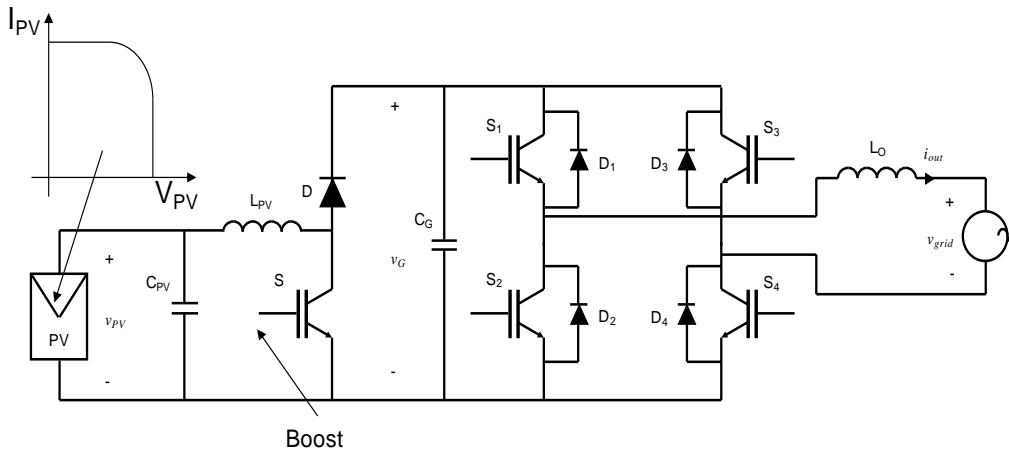

Figure 4. Grid connected photovoltaic inverter system

4. INVERTER CONTROL

The control structure that has been implemented for the single-phase inverter is shown in Figure 5. The photovoltaic system consists in photovoltaic generator (PVG), a maximum power point tracking (MPPT) and the inverter as shown in Figure 5. The control structure proposed for the single-phase inverter corresponds to 2 control loops [12-15].

- An external control loop of the DC voltage is necessary to maintain the DC-bus voltage constant to guarantee the correct function of the MPPT.
- An internal control loop of the current is designed to control the power injected into the grid. This allows the output current control in instantaneous values. To impose a sinusoidal current, in phase with the grid voltage, the reference current I_{ref} , is generated from a sinusoidal reference, the amplitude is regulated from the output of the external voltage loop.

The DC-bus voltage of the PV system is maintained constant such that active power balance between the injecting solar energy and the system output power can be achieved. The DC-bus voltage V_{dc} , can be fed back and compared with the desired value of $V_{dc}(ref)$ while a PI regulator is added to regulate the error between the desired voltage and the actual DC bus voltage, hence the reference current signal can be obtained. The current regulator is employed to regulate the error between the desired current and actual output current. One of the advantages provided by this control strategy is its simplicity as far as the computational requirements of the control circuit.

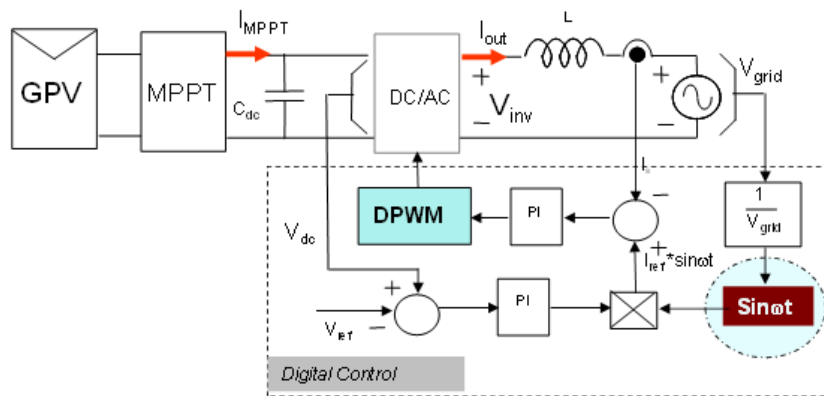

Figure 5. Control structure of the inverter connected to the grid

This structure is associated with proportional integral controllers (PI). To improve the performance of the PI controller in such a current control structure and to cancel the voltage ripples of photovoltaic generator, due to variations in the instantaneous power flow through the photovoltaic system, will depend on

one hand on the change of atmospheric conditions (mainly the irradiance and temperature), the faster response of the boost control loop, the inverter and the value of the DC bus capacitor. On the other hand, the output voltage is the mains voltage, represents an external disturbance of considerable magnitude at 50Hz for the system, there exists a compensation of these effects at the output of the PI controller so as to calculate directly the reference voltage for the inductance. Figure 6 shows the control loop of the inverter output current. The inverter output current expression is given:

$$I_{out}(s) = \frac{D \cdot V_{GPV}(s) - V_{out}(s)}{Ls} \tag{1}$$

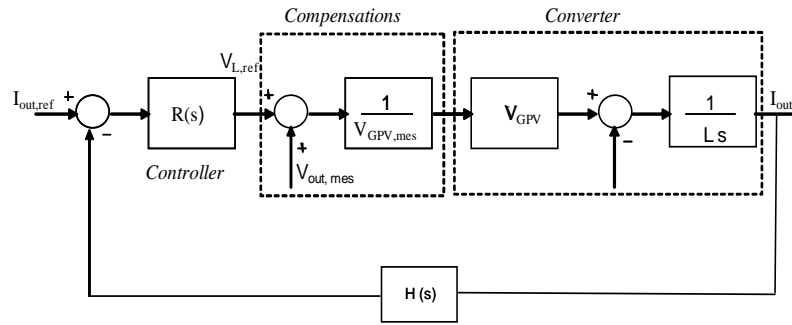

Figure 6. Control loop structure of alternative output current

The feed-forward technique is based on including new terms to variables control, in this case the duty cycle, in order to eliminate the dependence related to the perturbations of control system. To compensate the effect of output voltage, is used the average and filtered output voltage values, called $V_{out,mes}$, Figure 7. However, to compensate the voltage V_{GPV} , it's necessary to use, the measured value before filtered. In this case, it's required a duty cycle calculate since the transfers functions:

$$d = \frac{v_{L,ref} + v_{out,mes}}{v_{out,mes}} \tag{2}$$

K_{sv} the same step of measured circuits, obtained:

$$d = \frac{v_{L,ref} + K_{sv} v_{out}}{K_{sv} v_{GPV}} \tag{3}$$

From the duty cycle, the inductance voltage V_L

$$v_L = d v_{GPV} - v_s = \frac{v_{L,ref}}{K_{sv}} \tag{4}$$

The advantage of this control structure is the control of the instantaneous power injected into the grid from the solar module and the synchronization of the current signal with the grid voltage (Voltage and current in phase) which guarantee a higher power factor and improve the MPPT dynamic. The disadvantage is the noise in the inverter output current signal due to the use of the grid signal sample to generate and synchronize the reference current with the grid signal.

5. DIGITAL IMPLEMENTATION

The Digital Pulse-Width-Modulator (DPWM) converts the code in pulsating signal and generates the driving signals of the switches (T_1, T_2, T_3, T_4). The synchronization of the voltage grid and the inverter output current injected to the grid is assumed with the zero crossing detector (ZCD). This is accomplished by generating a synchronism signal in each crossing by zero of the grid voltage. In Figure 7 is shown the digital implementation of the bipolar PWM. The switching frequency is 10kHz in order to reduce harmonics.

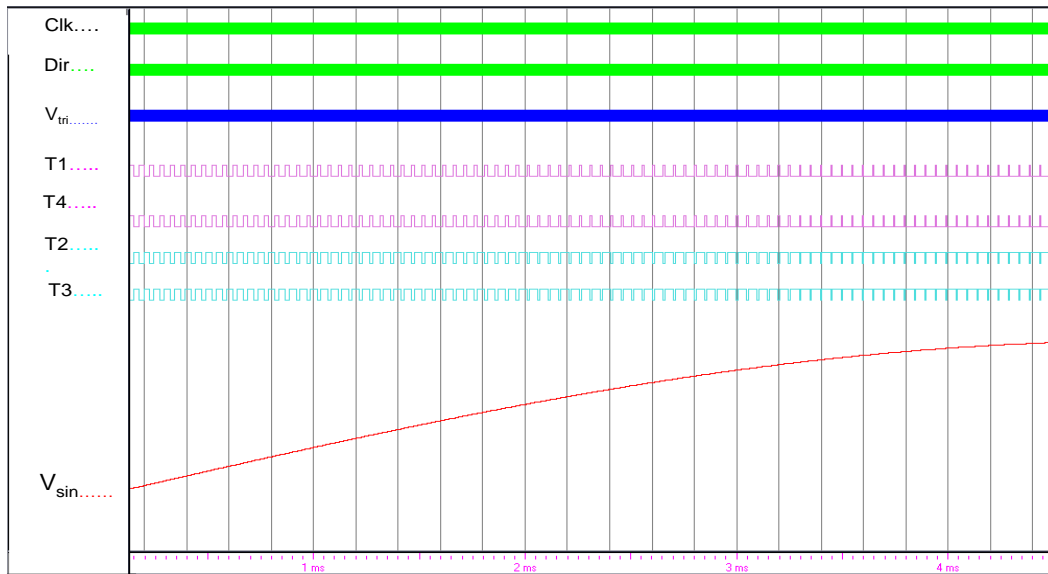

Figure 7. DPWM signals

6. SIMULATION RESULTS

The photovoltaic generator (PVG), the maximum power point (MPPT) and the single-phase inverter DC/AC behavior have been modeled and simulated by PSIM. The simulation parameters used are: voltage V_{grid} 230 V, frequency 50 Hz, $L = 4.7$ mH, $V_{dc} = 375$ V and frequency modulation index $mf = 200$. Simulation results of the photovoltaic system connected to the grid are presented .In Figure 8 (a), all results signals of the input side of PV system connected to the grid can be seen. The DC bus, the output current of PV module, the output current of the boost. Figure 8 (b), shows the simulation results of the inverter average model closed loop, the inverter output current, I_{out} in phase with the grid voltage V_{grid} and the inverter output voltage.

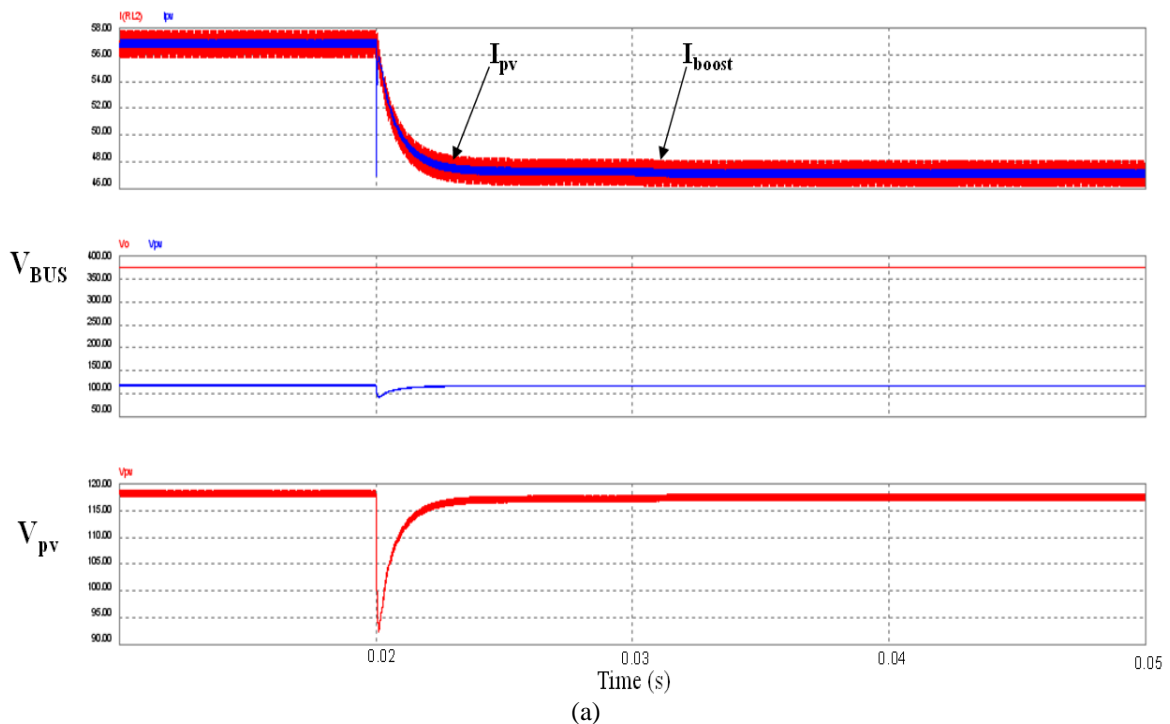

Figure 8. Output signals of PV system, (a) Inverter output current I_{out} , grid voltage V_{grid}

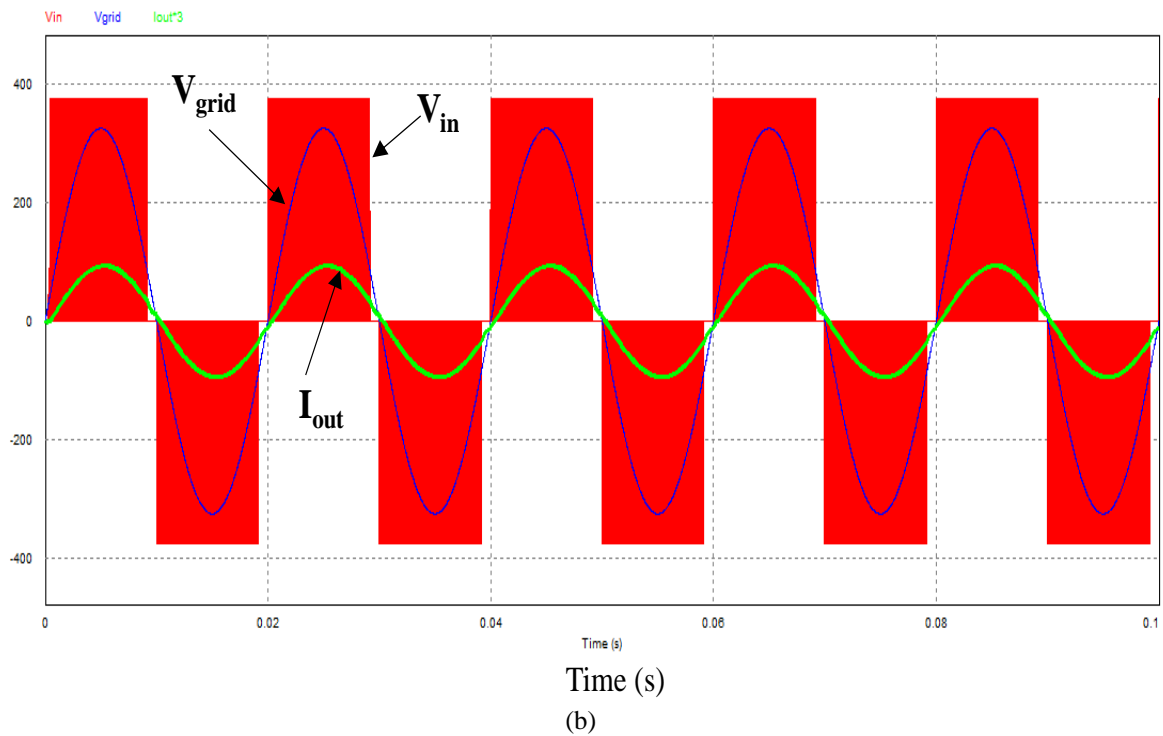

Figure 8. Output signals of PV system (b) inverter output voltage (*continue*)

7. EXPERIMENTAL RESULT

Figure 9 shows a prototype of single-phase inverter with the digital control implemented in a FPGA platform (Spartan-3 of Xilinx) realized and tested. $V_{grid} = 230$ V, and coupling inductance $L = 20$ mH. Figure 10(a) shows the PWM switching signals, inverter output current I_{out} and grid voltage V_{out} . Figure 10(b) shows Inverter output current I_{out} and inverter output voltage V_{inv} (b).



Figure 9. Single-phase inverter prototype

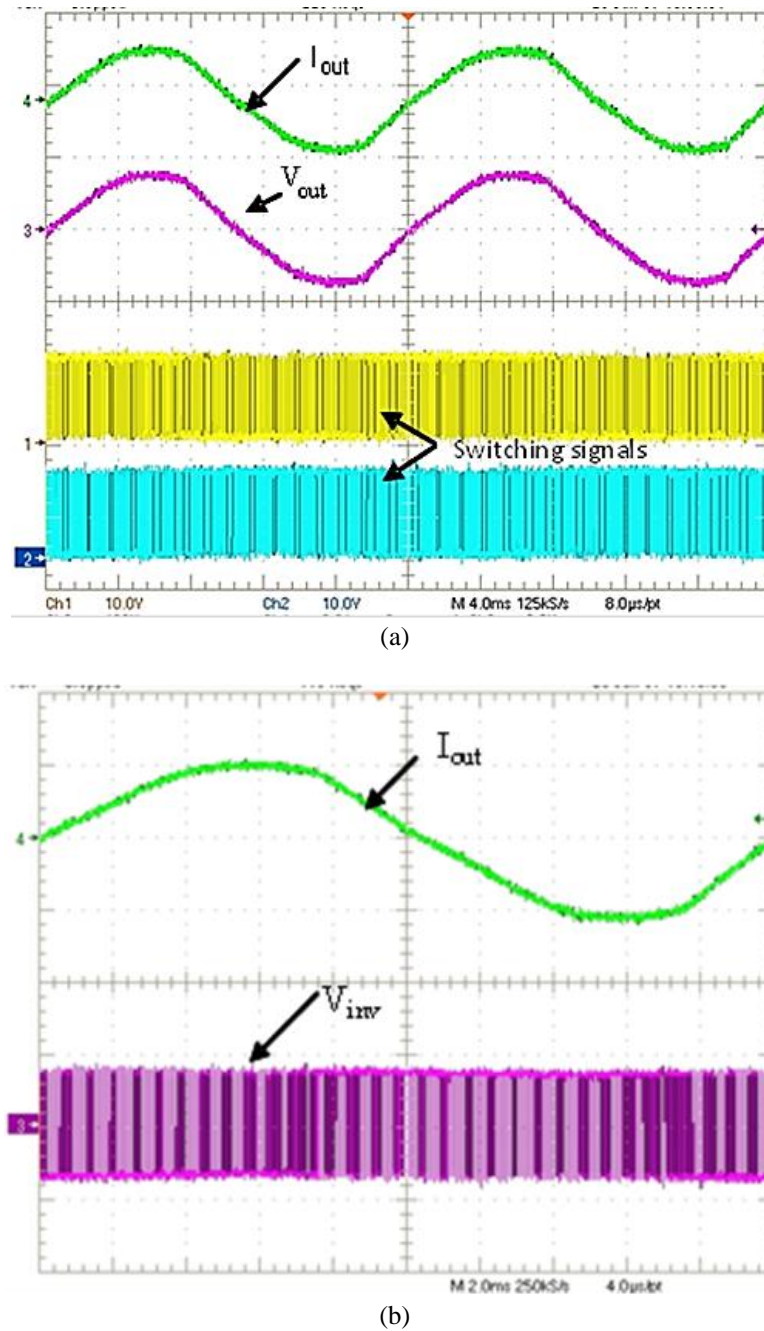

Figure 10. PWM signal, (a) inverter output current I_{out} and grid voltage V_{out} ,
(b) Inverter output current I_{out} and inverter output voltage V_{inv}

8. CONCLUSION

The paper has focused on the design and implementation of the control technique of PV inverter connected to the grid. This control is based on H-Bridge inverter controlled by digital pulse-width modulation (DSPWM) which can synchronise a sinusoidal current output with a grid voltage and control a power factor. The simulation results validate the theoretical predictions and demonstrate the viability of the proposed control. The experimental results show the viability of the bipolaire DSPWM method proposed, the simplicity of the digital implementation. The technique confirm that the control can be applied to control the power and the current injected into the grid. Using Xilinx FPGA to generate PWM provides flexibility to modify the designed circuit without altering the hardware part. This system can improve the power quality output of grid connected PV inverters and lower equipment costs for these systems.

REFERENCES

- [1] X. S. Li, *et al.*, "Analysis and Simplification of Three-Dimensional Space Vector PWM for Three-Phase Four-Leg Inverters," *IEEE Transactions on Industrial Electronics*, vol. 58, pp. 450-464, Feb. 2011.
- [2] M. Calais, J. Myrzik, T. Spooner and V. G. Agelidis, "Inverters for single-phase grid connected photovoltaic systems-an overview," *2002 IEEE 33rd Annual IEEE Power Electronics Specialists Conference. Proceedings (Cat. No.02CH37289)*, Cairns, Qld., Australia, vol. 4, pp. 1995-2000, 2002.
- [3] S. B. Kjaer, J. K. Pedersen, and F. Blaabjerg, "A Review of Single-Phase Grid-Connected Inverters for Photovoltaic Modules," *IEEE Transactions on Industry Applications*, vol. 41, no. 5, 2005.
- [4] L. Hassaine, E. Olfias, J. Quintero, and V. Salas, "Overview of Power Inverter Topologies and Control Structures for Grid connected Photovoltaic Systems," *Renewable & Sustainable Energy Reviews*, vol. 30, pp. 796-807, Feb. 2014.
- [5] Y. Yang and F. Blaabjerg, "Overview of single-phase grid connected photovoltaic systems," *Electric Power Components Systems*, vol. 43, no. 12, pp. 1352-1363, Jul. 2015.
- [6] Y. Yang, F. Blaabjerg, H. Wang, and M. Simoes, "Power Control Flexibilities for Grid-Connected Multi-Functional Photovoltaic Inverters," *IET Renewable Power Generation*, vol. 10, no. 4, pp. 504-513, 2016.
- [7] L. Hassaine and A. Mraoui, "Control strategy based on SPWM switching patterns for grid connected photovoltaic inverter generation systems," In: *AIP conference proceedings*, American Institute of Physics Inc., vol. 1814, 2017.
- [8] L. Hadjidemetriou, E. Kyriakides, Y. Yang, and F. Blaabjerg, "A synchronization method for single-phase grid-tied inverters," *IEEE Transaction on Power Electronics*, vol. 31, no. 3, pp. 2139-2149, 2016.
- [9] S. A. Khajehoddin, M. Karimi-Ghartemani, A. Bakhshai, and P. Jain, "A power control method with simple structure and fast dynamic response for single-phase grid-connected DG systems," *IEEE Transaction on Power Electronics*, vol. 28, no. 1, pp. 221-233, Jan. 2013.
- [10] M.R. Bengourina, M. Rahli, S. Slami, L. Hassaine, "PSO based direct power control for a multifunctional grid connected photovoltaic system," *International Journal of Power Electronics and Drive System (IJPEDS)*, vol. 9, no. 2, pp. 610-621, Jun. 2018.
- [11] L. Hassaine, E. Olfias, J. Quintero, and A. Barrado, "Power Control for Grid Connected Applications based on the Phase Shifting of the Inverter output Voltage with respect to the Grid Voltage," *International Journal of Electrical Power and Energy Systems*, vol. 57, pp. 250-260, 2014.
- [12] L. Hassaine, M.R. Bengourina, "Design and digital implementation of power control strategy for grid connected photovoltaic inverter," *International Journal of Power Electronics and Drive System (IJPEDS)*, vol. 10, no. 3, pp. 1564-1574, Sep. 2019.
- [13] L. Hassaine, E. Olfias, J. Quintero, and A. Barrado, "Digital Control based on the Shifting Phase for Grid Connected Photovoltaic Inverter," in *IEEE Applied Power Electronic Conference and Exposition*, pp. 945 - 951, 2008.
- [14] X. Wang, P. C. Loh, and F. Blaabjerg, "Stability Analysis and Controller Synthesis for Single-Loop Voltage-Controlled VSIs," *IEEE Transaction on Power Electronics*, vol. 32, no. 9, pp. 7394-7404, Sep. 2017.
- [15] N. Chaitanya, P. Sujatha, K. Chandra Sekhar, "Current Controller Based Power Management Strategy for Interfacing DG Units to Micro Grid," *International Journal of Electrical and Computer Engineering (IJECE)*, vol. 7, no. 5, pp. 2300 ~ 2308, Oct. 2017.
- [16] G. Vijaykrishna and Y. Kusumalatha, "Design and Implementation of Three Phase Reversing Voltage Multilevel Inverter," *International Journal of Applied Power Engineering (IJAPE)*, vol. 5, no. 2, pp. 59-71, Aug. 2016.
- [17] Shamala N, and C. Lakshminarayana, "Performance Enhancement in Active Power Filter (APF) by FPGA Implementation," *International Journal of Electrical and Computer Engineering (IJECE)*, vol. 8, no. 2, pp. 689 ~ 698, Apr. 2018.
- [18] N. Chettibi and Mellit, "A FPGA-based real time simulation and control of grid-connected photovoltaic systems," *Simulation Modelling Practice and Theory*, vol. 43, pp. 34-53, Apr. 2014.
- [19] M. Parvez, M. F. M. Elias, N. A. Rahim, and N. Osman, "Current control techniques for three-phase grid interconnection of renewable power generation systems: A review," *Solar Energy*, vol. 135, pp. 29-42, 2016.
- [20] F. S. Lin, J. F. Chen, T. J. Liang, R. L. Lin, and Y. C. Kuo, "Design and implementation of FPGA-based single stage photovoltaic energy conversion system," *The 2004 IEEE Asia-Pacific Conference on Circuits and Systems*, 2004, Proceedings, Tainan, pp. 745-748, 2004.
- [21] S. J. Pinto, G. Panda and R. Peesapati, "An Implementation of Hybrid Control Strategy for Distributed Generation System Interface Using Xilinx System Generator," in *IEEE Transactions on Industrial Informatics*, vol. 13, no. 5, pp. 2735-2745, Oct. 2017.
- [22] A. V. Peterchev and S. R. Sanders, "Quantization resolution and limit cycling in digitally controlled PWM converters," in *IEEE Transactions on Power Electronics*, vol. 18, no. 1, pp. 301-308, Jan. 2003.
- [23] C. Buccella, C. Cecati and H. Latafat, "Digital Control of Power Converters—A Survey," in *IEEE Transactions on Industrial Informatics*, vol. 8, no. 3, pp. 437-447, Aug. 2012.
- [24] A. RezaReisi, H. M. Moradi, and S. Jamasb, "Classification and comparison of maximum power point tracking techniques for photovoltaic system: a review," *Renew. Sustain. Energy Rev.*, vol. 19, pp. 433-443, 2013.
- [25] Hassan Abouobaida, and EL Beid Said, "Practical Performance Evaluation of Maximum Power Point Tracking Algorithms in Photovoltaic System," *International Journal of Power Electronics and Drive System (IJPEDS)*, vol. 8, no. 4, pp. 1744-1755, Dec. 2017.