

Hybrid controller strategy for optimization of cumulated thermal stresses, induced in X-raystube for medicaluse

Rachedi Mohamed, BouananeAbdelkrim

Department of Electrical, Faculty of Technology, L.G.E Laboratory Electrical Engineering,
University Dr. MoulayTahar, Algeria

Article Info

Article history:

Received Jul 15, 2018

Revised Apr 19, 2019

Accepted Apr 27, 2019

Keywords:

Cumulated stresses

Damping

Hybrid controller

Optimization

X-rays tube

ABSTRACT

This work presents a new control strategy of the power supply, in favor of equipment intended for the medical use. Several research investigations have been reserved for the service of this supply type, but there are still some disadvantages, which have challenged their high performance in the practical side, in particular the problems which concern the weight, the size and especially, the efficiency of these installations and this, on the cost side, energy balance, and lifetime of this equipment. A control technique is presented to overcome these constraints; its principle is based on the deduction of a hybrid control of which two controllers are simultaneously used for the same radiological dose, known by the fuzzy logic and the PID which have already been tested [1, 3]. This hybrid control has been greatly enhanced and developed, thanks to its robustness against the various intolerable dynamic states applied to the system and also to the unpredictable external disturbances.

*Copyright © 2019 Institute of Advanced Engineering and Science.
All rights reserved.*

Corresponding Author:

Rachedi Mohamed,

Faculty of Technology,

Department of Electrical, Laboratory of Electrical Engineering, L.G.E,

University Dr. MoulayTahar. Saida, Algeria.

Email: mohamed.rachedi@univ-saida.dz

1. INTRODUCTION

Medical imaging is currently considered one of the hubs of modern medicine in diagnostics and therapeutics. Manipulators in radiology saw their competence spread rapidly in relation especially, with the devastating development of radiological equipment more and more pointed. Supplying this type of X-ray generators requires high voltages with great stability, especially, the development of severe control during the dynamic stage to counteract overruns, which induce intolerable overvoltage. Therefore, an excessive dissipation of energy will be put into play; however a heat sequence concealed in the X-ray tube which degrades the energy efficiency, until the destruction of the tube.

In this perspective several research investigations aimed at optimizing the performance of these equipments, such as size, weight and volume [1], as well as conventionally recognized control means have been adopted and tested. Several control commands have been made to meet these conditions. Among these strategies, PID controllers and fuzzy logic have been used separately and have been able to provide satisfactory results [2]. However, a comparative analysis has made it possible to better concretize the degree of contribution of each of the two controllers [3]. But today, these measures are still insufficient in the face of massive demand, which instantly claims successive radiological doses. As a result, the major problem of this equipment is the cumulative thermal stress induced in the enclosure of the X-ray generator tubes, which strongly dampen the cooling curve of these tubes.

A new hybrid controller technique, which allows dual simultaneous assistance of both PID controllers and fuzzy logic, and this, by permutation, roles of each of the two controllers, in favor of the same

radiological catch. This version of hybrid controller, may be the most suitable solution to maintain a permissible temperature of the enclosure of the tube. In parallel, the system must be subjected to a damping greater than or equal to one, as a necessary and sufficient condition for adaptation of this new control strategy. In this approach, a series-resonant DC-DC converter has been adopted, as is shown in figure 1, of which the resonant circuit L_R-C_R consists of:

- The HF/HV transformer primary leakage inductance, including the inductance of the installation network.
- Parasitic capacitance of the secondary winding layers of the HF / HV transformer, including the selected capacitor on the installation network side [4].

Since the damping of the system is analytically in relation to the resonant circuit, and the load expressed by the fictitious resistance of the X-ray tube, which is a device for dissipating the electric power [5], then, an adequate choice of this resonance circuit, must validate the compliance of this power supply with practice. As a result, the range of loads considered is standardized in accordance with the damping, which is previously set by the resonant circuit L_R-C_R . Therefore, a load selector is called capable of assigning each time the hybrid controller variant needed, according to the damping of the system to perform the desired take of radiology. However, the type of hybrid control is easily chosen to achieve the desired performance.

While respecting the conditions recommended previously, the results obtained were very satisfactory because, the performances of the controller in question established simultaneously, a dynamic state strongly damped, and a static state largely stable and this, in comparison with the results obtained with the two type controllers, used separately.

2. MAIN STAGES OF POWER CIRCUIT FOR RADIOLOGICAL INSTALLATION

In practice, the high supply voltage is generated in a wide range (the order of tens of kV) with currents supplying the anode filament contained in the radio-gene tube, to excite the liberation of X-rays particles. The realization of this power supply uses a DC-DC- resonant converter, equipped with an HF/HT transformer, from which the semiconductors operating at high frequencies are required. Generally, the presentation of this type of assembly is simplified by the presentation of an unfiled installation, as shown in Figure 1.

The major problem of this equipment is reflected by the thermal stresses induced in the enclosure of the generator tubes, and this, following successive radiological take-off actions causing thermal accumulations, which strongly compete with the cooling flow of tubes as explained in Figure 2. Therefore, the supply of this type of X-ray generators requires high voltages characterized by high stability, because the emission of X-rays must be carried out for a very short time. Another condition is imposed; it is the elimination of overvoltage that causes the destruction of the tube.

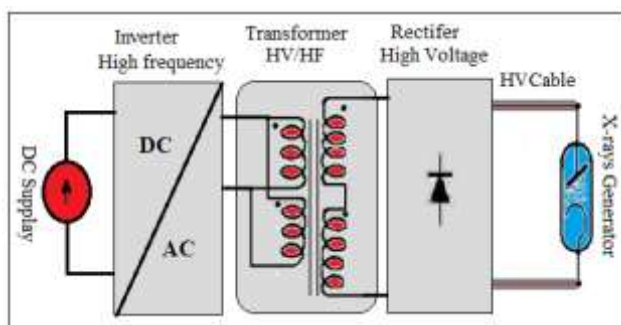

Figure 1. Principal supply of radiological installation

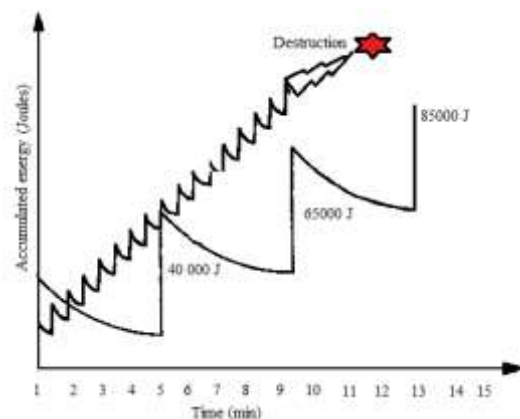

Figure 2. Exposure of the X-rays tube enclosure, to thermal stress, induced by accumulations

3. THE RECOMMENDATIONS OF ENERGY QUALITY IN MEDICAL IMAGING

In practice, certain international standards must be imperatively respected, for the setting under stress of this type of installations, and this, in view of its vital reaction on the patient's path. The generator of an X-ray tube must have the ability to change and adjust X-ray emissions for a very short time. And control the dose assigned to each taken in radiology.

Indeed, an overvoltage can be the object of undesirable arcs against the tube and then, accompanied by a considerable dissipation of energy and consequently, the risk of the destruction of the X-ray tube. Of these facts, an X-ray generator must have the following essential characteristics:

- The transient response is fast, this is valid for the regulation of a wide range of loads.
- The over voltages induced by the overruns must be absolutely eliminated.
- The ripple factor of the output voltage is rated in the static state.

The efficiency of the production of X-rays is very low so, much of the electrical energy is consumed as heat in the X-ray tube enclosure [5]. The exposure parameters controlled by the operator are:

- The voltage (kV), representing a high potential difference between the anodic filament and cathode.
- The intensity (mA), representing the amount of X-ray products.
- The exposure time (ms) also representing the amount of radiation X.

4. ADOPTION OF SERIES RESONANT CONVERTER, SUPPLYING AN X-RAY TUBE

The block diagram of the power circuit is given by Figure 3, which specifies the main stages and the constituent elements of this supply type, through which is manifested the transfer of power. In this type of application, the input is a direct voltage source connected to an inverter, which delivers periodic waveforms at high frequencies; with an order that attains 50 kHz. So in this application, an transformer high voltage and high frequencies, will be required whose model is illustrated in Figure 3.

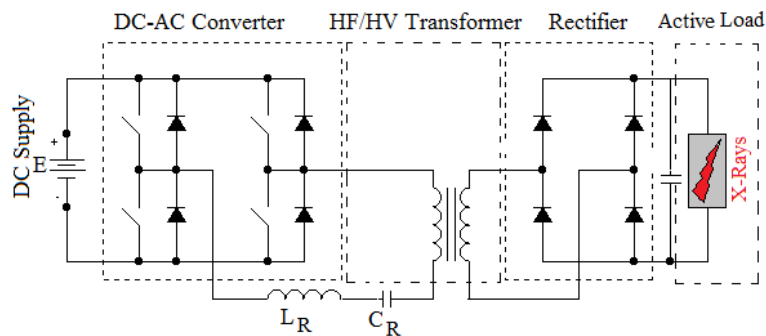

Figure 3. The series resonant converter structure, supplying an X-ray tube

The recommendation of such a transformer is analytically justified by its ability to operate, optionally with an optimal magnetic flux density before saturation, and capable of establishing a balance of power losses as low as possible, and therefore, less heating. The secondary of this transformer is the seat of a high voltage with high frequencies, which, after recovery applied to the X-ray tube terminals.

In view of the favorable switching conditions of the rectifier, the series resonance converter has a structure which is certainly better adapted to high frequency operation. As a result, the field of investigation is deliberately limited to the series resonance converter, and more particularly to that operating at a frequency higher than the resonant frequency.

A simplification of the system in the present application was established, while preserving the technical and economic performance of the assembly operation. Figure 4 shows the electrical diagram of the high-frequency DC-DC resonant converter designed to supply the X-rays tube at high voltage, which is similar to a fictif resistive load. The inverter is equipped with semiconductor components, type IGBT, capable of switching with high frequencies.

Taking into account the validated model of the HF/HV transformer [6], the system comprises the following reactive components:

- L_R ; inductance of the oscillating circuit containing the leakage inductance of the transformer primary L_1 .
- C_R ; compensation capacitor.
- C_p ; parasitic capacitance distributed between the secondary windings of the HF transformer.

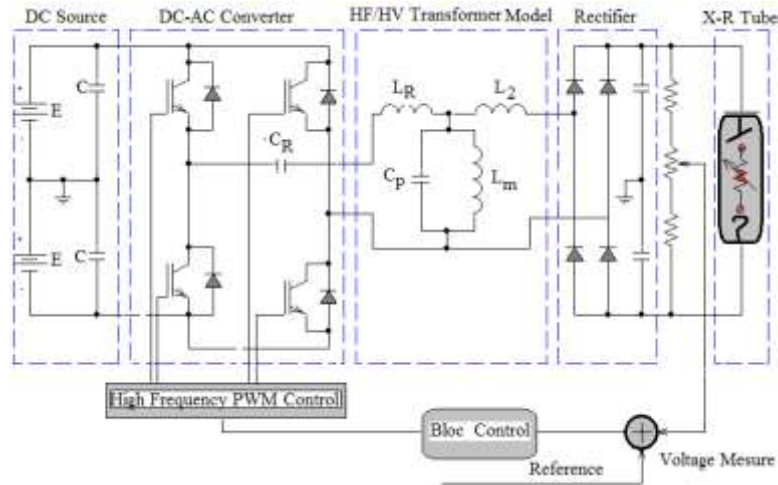

Figure 4. Stages of power circuit DC-DC converter with HF/HV transformer model elements

5. CONTRIBUTION OF RESONANT SUPPLY IN SOFT SWITCHING OF IGBT

The resonant circuit L_R - C_R can contribute strongly to the establishment of the soft switching of the semiconductors, and this, between two successive commutations. Figure 5 and Figure 6 shows the waveforms of the collector-emitter voltage of the IGBT and the collector current during the open and close commutations. These waveforms demonstrate that the resonant pair L_R - C_R , allows a resonant frequency aligning the switching frequency of the semiconductors, can effectively establish a spontaneous soft switching. Indeed, in resonance, the switches can take advantage of either a zero current switching (ZCS) during closing or a zero voltage switching (ZVS) when opening the semiconductor component [7, 8].

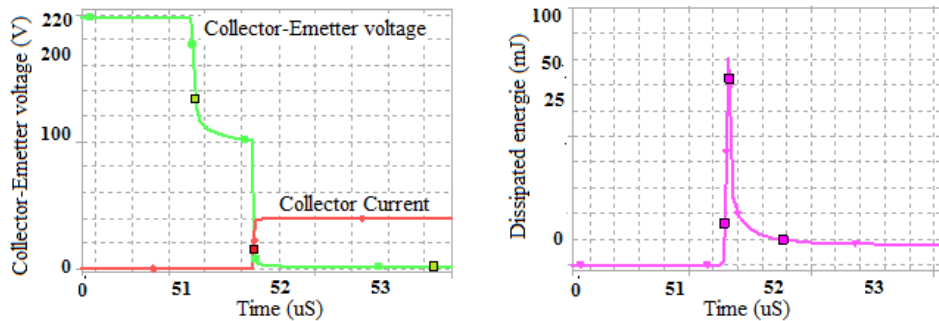

Figure 5. Wave forms of the collector-emitter voltage, the collector current, and dissipated power, with switching on mode IGBT, at high frequencies

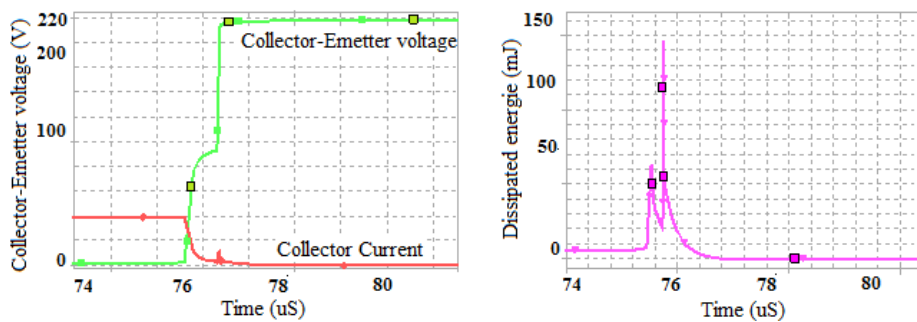

Figure 6. Wave forms of the collector-emitter voltage, the collector current and dissipated power, with switching off mode IGBT, at high frequencies

6. MODELING OF TRANSFER POWER IN DC-DC RESONANCE CONVERTER

In practice, the operator sets the parameters assigned for each radiological dose, according to the desired prescription of medical imaging. Then, this is translated in the X-ray tube a successive energetic dissipation (W) of the active power.

$$W = P \cdot t \quad (1)$$

Thus, the X-ray tube is exposed to thermal stresses that are limited by the manufacturing standards. As a consequence of deduction, the X-ray tube is considered to be an overall intrinsic load, of a resistive nature, from which the amount of active power is dissipated. Not to be confused with the filament resistance of the anode in the tube, which is, also included in this same overall resistance.

The L_R - C_R couple is a determining factor in the quality of the output response of the system because of its ability to affect the system in three ways:

- Effect of L_R - C_R series resonance.
- Effect on the system in transitory state and in static state.
- Direct effect on the load nature, implied, the damping of the system.

Figure 7 illustrates the topology sequences for each instantaneous value of the output response named V_s , and those, during a period of time T having a very small value, since the system in question operates at high switching frequencies of semi-conductors.

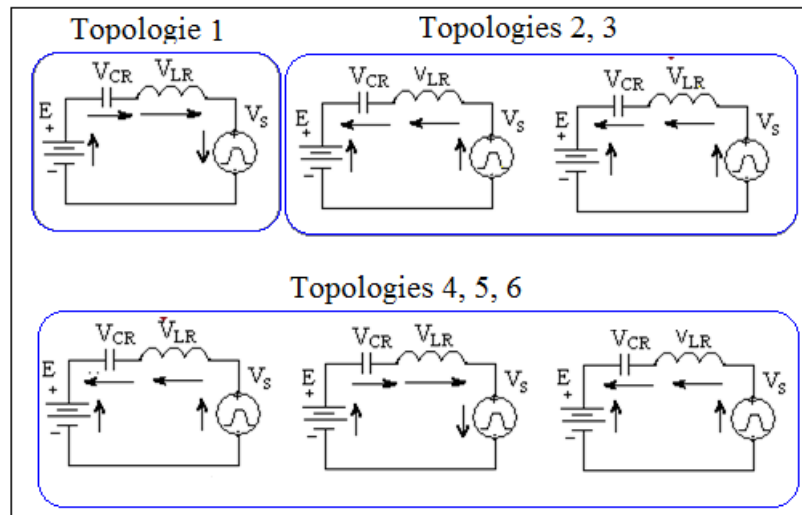

Figure 7. Topologies sequences of DC-DC converter operating during one period T

- Topologie 1; $0 \leq t \leq T/6$:

$$V_{S1} = E - (V_{CR} + V_{LR}) \quad (2)$$

- Topologies 2 and 3 : $T/6 \leq t \leq 3 \cdot T/6$:

$$V_{S2} = -E - (V_{CR} + V_{LR}) \quad (3)$$

- Topologies 4, 5 and 6 : $T/6 \leq t \leq T$

$$V_{S3} = -E - (V_{CR} + V_{LR}) \quad (4)$$

$$V_{CR} = (1/C_R) \int i_C \cdot dt \quad (5)$$

$$V_{LR} = L_R \cdot di/dt \quad (6)$$

L_R and C_R are respectively the inductor and capacitor of series resonant circuit.

By introducing (5) and (6) in each topology equation, a system of differential equations whose solution will be able to describe the static and dynamic characteristics of the whole system. Then, a simplifying approach of the Fourier transformation, allowing the appearance of the main parameters, which establish the modes of operation of this type of assembly. However, after having made the necessary transformations, a new system of equations results:

$$Vs_1 = (p \cdot k / (p^2 + 2 \cdot \zeta \cdot w \cdot p + w^2)) \tag{7}$$

$$Vs_2 = -(p \cdot k / (p^2 + 2 \cdot \zeta \cdot w \cdot p + w^2)) \tag{8}$$

$$Vs_3 = -(p \cdot k / (p^2 + 2 \cdot \zeta \cdot w \cdot p + w^2)) \tag{9}$$

$$Vs_4 = (p \cdot k / (-p^2 + 2 \cdot \zeta \cdot w \cdot p - w^2)) \tag{10}$$

$$Vs_5 = (-p \cdot k / (p^2 + 2 \cdot \zeta \cdot w \cdot p - w^2)) \tag{11}$$

$$Vs_6 = (-p \cdot k / (p^2 + 2 \cdot \zeta \cdot w \cdot p - w^2)) \tag{12}$$

Equation(7) to (12) represents the responses in open loop voltage V_s of the cathode X-ray tube with load factor as expressed by: $Q = Z/R$, Z is the characteristic system impedance. Then, next parameters will be adopted:

- System pulsation:

$$w = 1 / (L_R \cdot C_R)^{1/2} \tag{13}$$

- System gain factor with load resistance nature:

$$k = R \cdot C_R \cdot w^2 \tag{14}$$

- Proper system impedance:

$$Z = 2 \cdot (L_R / C_R)^{1/2} \tag{15}$$

- Proper load damping:

$$2 \cdot \zeta = R \cdot (C_R / L_R)^{1/2} \tag{16}$$

- Proper load damping:

$$4 \cdot \zeta = R \cdot Z \tag{17}$$

7. OUTPUT SYSTEM RESPONSES IN OPEN LOOP

From the point of view of stability, these replies are mainly subject to strong or weak depreciation according to the design of the system in question. So, these responses are similar to those of a second order system in open loop as is showed in Figure 8.

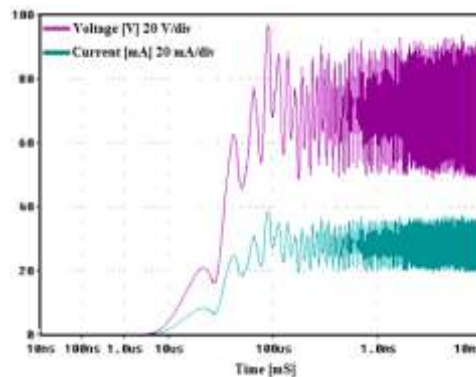

Figure 8. Output characteristics of cathode voltage and anode current, with system in open loop

The output characteristics of the system are shown without adequate control; these forms of waves decay the transient regime, which announces intolerable overruns and more durable. On the other hand, steady state is very difficult to reach in terms of stabilization. This is due to the persistence of oscillations, weakly damped. This allows, instructively use a regulation more efficient, to refine these shortcomings. These responses are devoid of qualifications and are not recommended in medical imaging because this conventional supply type should be absolutely required to reduce extremely the delivered tube voltage ripple. In practice, the range of loads listed in the catalog is indicated by standardized values.

On the other hand, the global resistance reflecting the load of the system is strongly subject to the proportion ($R = U / I$), and therefore, any conventional radiological dose must be applied by assigning the value of the voltage, which is accompanied with its own current value. However, the equation(18), allows introducing the condition of stability of the system, according to the following relation:

$$\zeta \geq 1 \quad (18)$$

Introducing the condition (18) in (17), so as to substitute the load condition to be endorsed by the operator. Let Z be the system's own impedance, so the conditions for designing a load are given as follows:

$$R \geq 4 \cdot 1/Z \text{ and } U/I \geq 1/Z \quad (19)$$

8. COMPARATIVE STUDY ON THE QUALITY OF DC-DC CONVERTER RESPONSES SUBMITTED TO CONTROL

Before starting the new investigation, concerning the hybrid control strategy, some research work has already been carried out. Thus the results obtained have been described as satisfactory, but over time, this type of supply, claims again an even more extensive management in terms of regulation. In order to obtain high quality power factor and continues DC power density absorption, robust method control of tube cathode voltage and anode current in dynamic and static stat an active parallel filtering type voltage will be associate [5]. In this conventional practical type adjustment of load current power factor tacked very satisfied values. Mainly contribution to developer optimal high DC power supply consists to apply the technical fuzzy logic control and PID regulator as a comparison tool. Figure 9 describes basic process regulation conditioning by the follows DC-DC property:

- Optimal transformer operating point witch permuted basic behavior of linear system.
- Favorable input current power factor delivered by installing appropriates parallel active filter.
- X-ray tube load is assimilated to resistor which is linearly proportional with temperature.

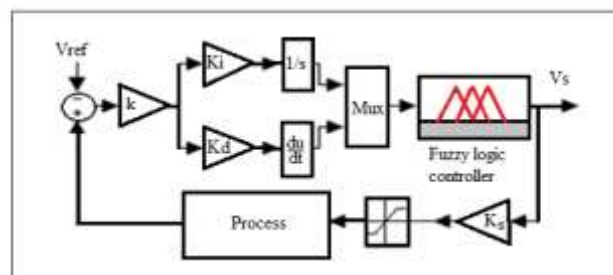

Figure 9. Control system bloc diagram using fuzzy logic regulation

In order to analyse proposed regulation efficiency there are two ways to exanimate output system stability, the first one is reduce in shorter time repetitive over-voltage which causes X-ray tube destruction during transient state, the second one concerns elimination of steady state ripples and offers acceptable output response distortion factor.

To realise these performances it has compared output characteristics obtained by the PID regulator and those determined by fuzzy logic control. By using fuzzy logic controller, state transient side presents an exceptionally applied factor damping on the cathode voltage and anode current waves forms in comparison with results offered by the PID regulator as showed in Figures 10, 11 and 12. In opposition, perfectly steady state with best Factor power quality is illustrated with PID controller. Generally, establishment dynamic state system is realized during 50 milliseconds however, energy quantity liberated inter X-ray tube is admissible.

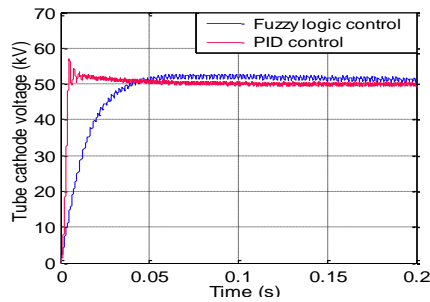

Figure 10. Contribution PID and fuzzy logic control in dynamic and static stat for low load

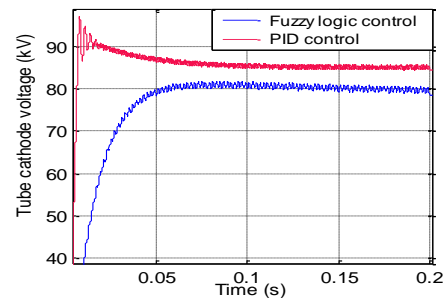

Figure 11. Contribution PID and fuzzy logic control in dynamic and static stat for heavy load

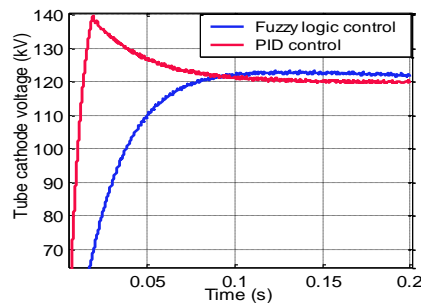

Figure 12. Contribution PID and fuzzy logic control in dynamic and static stat for heavy load.

As a result, the simulation results thus obtained make it possible to test the contributions of the fuzzy logic technique by comparing with those obtained by the PID regulator. Ideally the performances obtained in the dynamic state by the fuzzy controller, are very satisfactory compared to those offered by the conventional regulator and this, with less over voltage and static state more stable, and this, despite the large number of parameters to set in a fuzzy controller, comparing with the conventional PID.

9. CONTRIBUTIONS OF PERFORMANCES REQUIRED BY HYDRIDE CONTROLLER

In order to obtain high quality for supply power in voltage and current, it was proposed a control strategy for dynamic and static stat system with association PID and fuzzy logic [6]. Since the power involved is a function of the cathode voltage of the tube and the variable current of the anode filament in the tube. Since the power involved is a function of the cathode voltage of the tube and the variable current of the anode filament in the tube. Then, by deduction the load soliciting such a quantity of this power, directly influences the damping of the system. As a result, any increase in the value of the power is accompanied by a lower damping, which causes instability of the system. On the other hand, if the power involved is low, a relatively low damping is announced by the system.

9.1. Adaptation of dynamic states in case no standardized load

So, mainly, in this approach, it is necessary to take into consideration the overall resistance of the X-ray tube, which directly affects the damping of the system, as well as the voltage of the cathode of the tube. The wave's forms obtained in Figure 13 and Figure 14 shown the output characteristics of the X-ray tube power supply. In this case, the voltage of the cathode of the tube represents the major magnitude (kV), which causes the greatest dissipation of the power induced in the chamber of the tube, while the current is assumed constant through the resistance of the anode filament.

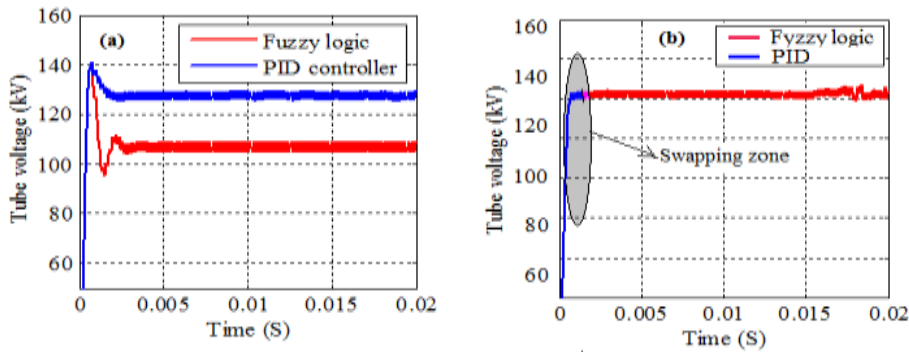

Figure 13. Output characteristics that are subject to low damping equal to 0.5

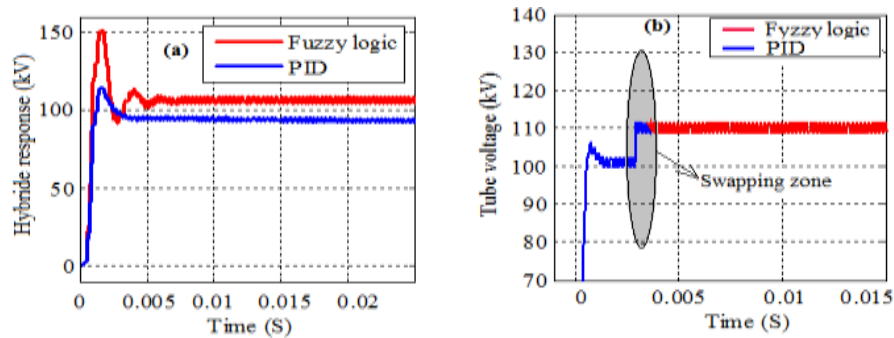

Figure 14. Output characteristics that are subject to low damping equal to 0.85

Figure 13(a) shows the shape of the voltage of the cathode ray tube, the system is countered at a damping equal to 0.5, in this case, the PID controller shows good performance in dynamic state, compared to the Fuzzy logic, which is passive against over voltages. On the other hand, these deficiencies were compensated by association the hybrid controller (PID-Fuzzy logic), which shows a great capacity for regulation. Figure 13(b).Shows swapping action, between the two controllers, established by hybrid controller, for damping 0.5. In the same way, the Figure 14(b) and illustrate advantages, of high qualities of responses, which are rated ideal and this with a damping equal to 0.85.

9.2. Adaptation of dynamic states, case standardized load

On the other hand, Figure 15, a reversal role is adopted to proceed to another hybrid control alternative, which assists both controllers in the same radiological catch. A limitation of the PID controller has been noted, in the face of the overruns during dynamic state, on the other hand the Fuzzy logic controller has developed a good rigidity in this state, which is announced overruns greatly softened. So Figure 15(b) illustrated the strongly swap action, between the two controllers, established by hybrid controller, damping 1.

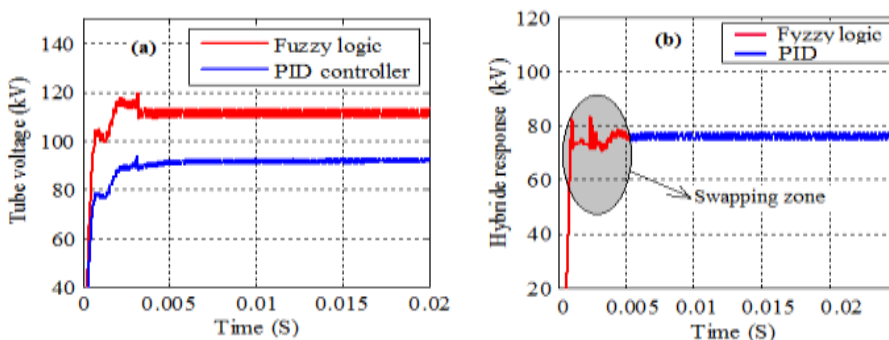

Figure 15. Output characteristics that are subject to low damping equal to 1

10. ANALYZES AND DISCUSSIONS OF THE RESULTS

Under the light of the results found, which are highly rated, it is necessary to know the type of load, which one wishes to supply, in order to standardize the electrical quantities quoted in the specifications. In this context, the system's own damping is fixed for each X-ray, a great softening of the overruns has been observed, with the PID controller, while with the Fuzzy Controller, the dynamic state suffers in some cases from exceeding. At the same time, high quality signals are obtained in a static state as watches in Figure 13 and Figure 14. Indeed, the strategy of the hybrid control whose two controllers share roles by switching. This technique offers ideal performance during the static and dynamic state. Nevertheless, these results are achievable for damping, which are selected low, between 0.5 and 0.85.

Differently to previous cases, Figures 15 and 16 shows clearly, the total control of transient and permanent state, thanks to the hybrid control. This realizing in very satisfactory response qualities, however, several load ranges have shown that the control swapping variant, between Fuzzy logic-PID is valid only for loads inducing damping greater than or equal to one (*normalized loads*). Even more interesting, for a damping higher than one ($\zeta > 1$), the waves forms obtained in Figure 16(b) and Figure 17(b), pronounced strongly, the satisfactory profitability of this control technique, and most importantly, the variant of the hybrid controller which assists the fuzzy logic in a dynamic state, then the PID controller which takes the raises in static mode. The test of robustness is simultaneously shown in Figure 18, which appear the spontaneity of the entire system, to reach its stability, and those, following a disturbance strongly injected by the external network.

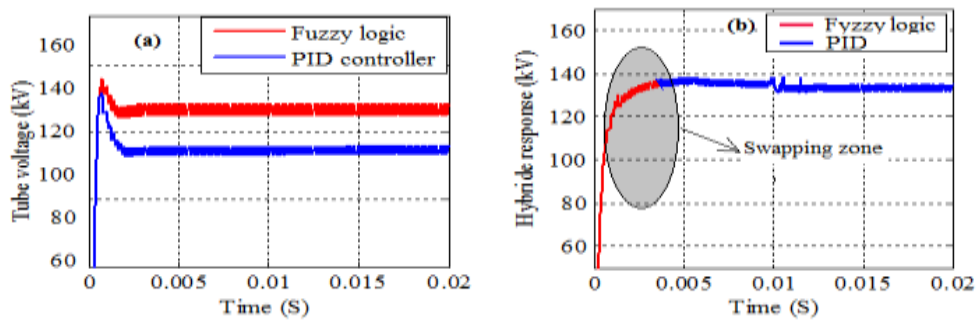

Figure 16. Output characteristics that are subject to low damping equal to 1.5

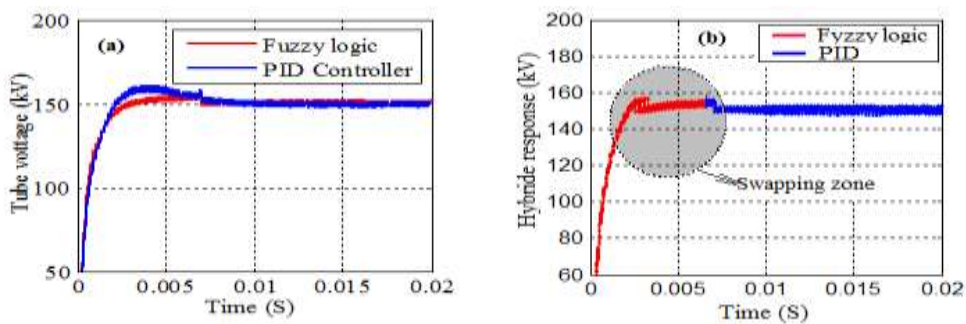

Figure 17. Output characteristics that are subject to low damping equal to 2

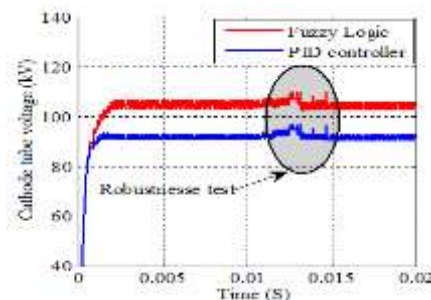

Figure 18. Robustness test of the two controllers, facing the disturbances

11. CONCLUSION

In this study, all the determining factors were taken into account in the assembly of medical imaging equipment, to import a contribution, with which, the performance of these equipments will be as much as before, the most ideal. The proposed technique is aimed primarily at the reduction of thermal accumulations, causing the destruction of the enclosure of the X-ray tube. This will allow increasing the number of successive radiological catches, without any preliminary reserves, this, is feasible only by respecting the directives imposed by the assembly in question.

According to several results obtained with different radiological doses, which, of course, correspond to the standard conditions, expressed by the electrical quantities, the version of the hybrid controller, using simultaneously, the Fuzzy logic controller of the transient side, and the PID controller in steady state, was the most appropriate strategy for this application. This regulation strategy remains valid, with a necessary and sufficient condition, which claims the system response, with a damping greater than or equal to one.

By respecting the standard norms, the interval dictates the load conditions, indicated in the specifications of this type of power supply in medical imaging; the hybrid controller can provide high stability performance and maintain robustness, especially in dynamic and static states. Consequently, this strategy calls for a load selector, capable of assigning each time, the hybrid controller option required for radiological capture. By selecting, the electrical parameters for the radiological dose; either the damping involved in the system, the type of hybrid control is easily chosen to obtain the desired signal.

REFERENCES

- [1] Y. Cheon, et al., "Study Of a Resonant Converter Using Power Transistors In 25 Kw X-Rays Tube Power Supply," *International Review Of Automatic And Control Power Electronics Specialists, ESA, Proceedings, IEEE*, vol. 5, pp. 295-306, 1985.
- [2] M. Rachedi and M. Bourahla, "Development of Control Strategy for DC-DC Converter by Adjusting the Optimum Operating Point of HF/HV Transformer," *International Review Of Automatic And Control (IREACO)*, vol. 4, pp. 414-420, 2011.
- [3] M. Rachedi and M. Bourahla, "Adaptation of Radiological Supply HV / HF for Medical use," *International review of physics (IREPHY)*, vol. 3, pp. 1311-139, 2009.
- [4] J. Sun and T. Nakaoka, "Mode PWM Dc-Dc Converter With A High Voltage Transformer Link And Its Control Methods For Medical Use X-Ray Power Supply," *EPE, August 1999*, Lausanne, vol. 7, pp. 514-521, 2011.
- [5] M. Rachedi and M. Bourahla, "Optimization Strategy of Distortion rate Control for High Power Transfer Supplying an X-ray Tube," *Journal of Electrical Engineering (JEE)*, vol. 63, pp. 81-87, 2012.
- [6] W. Gerard, et al., "Optimised Transformer Design: Inclusive of High -Frequency Effect," *Transaction on Industrial Electronics*, vol. 2, pp. 112-123, Jun 1998.
- [7] F. Lee, et al., "A Comparative Study of Switching Losses of IGBT's Under Hard .Switching, Zero Voltage Switching and ZCS," *International Conf. Rec. IEEE. PESC*, vol. 4, pp. 1196-1204, 1994.
- [8] J. Carlos, et al., "Novel ZCS PWM Converters," *Transaction on Industrial Electronics*, vol. 3, pp. 1242-1258, Mar 1997.

BIOGRAPHIES OF AUTHORS



Rachedi Mohamed born in 1966 June 30 to Youb (w) Saïda, Algeria. Graduated from the Faculty of Electrical Engineering (engineer) at the Bel-Abbes University of Technology in 1991 and took the position of assistant lecturer with the Department of Electrical of Saida University. In 2002 received his Master in the field of Electrical Power Engineering and control, in 2003, was appointed associate assistant Master from 2005 he is graduated Assistant Master category A. He was the President of the pedagogical Committee of the Faculty of Electrical Engineering in Saida (2005– 2007). He is attached to the laboratory control and optimization of electric drives, electrical engineering USTO, 2002. He has contributed at many international's publications and Conference. Having a doctorate in science at USTO University, Oran, Algeria, and then attached to LGE laboratory, Saida University. Until 2018, teacher providing, teaching courses, and directed work in metrology and teaches module of energy quality, with practical work. In parallel, assures the student leader in the axes of electronic power control.



Bouanane Abdelkrim is born in SAIDA, Algeria in 1970. I obtained a diploma of engineer in Electrotechnics in 1995. I received my Master in 2006 at the ENSET Oran and PHD at the ENPO oran in 2013. I am a teacher in the Department of Electrical Engineering, Faculty of Technology at the Dr. Moulay Taher University of SAIDA. My research interests include intelligent control of power system and FACTS, Electrical Machines and Renewable Energies. I am a member in electrotechnical engineering Laboratory (L.G.E).