

An active technique for power saving in WSN under additive white gaussian noise channel

Raad Farhood Chisab

Department of Electrical techniques, Technical Institute Kut, Middle Technical University (MTU), Iraq

Article Info

Article history:

Received May 5, 2018

Revised Sep 9, 2018

Accepted Sep 23, 2018

Keywords:

Additive white gaussian noise

Parameters optimization

Power minimization

Wireless sensor networks

ABSTRACT

The WSN works with feature of self-power supply by solar cell or by the battery or together at the same time. Therefore, the power dissipation is the big problem in wireless sensor network (WSN) especially when it is works for long time. The efficient method for reducing the power consumption within working is needed. The process of reducing waste power is one of the top priorities of scientists and designers of wireless sensor networks. The aim of this paper is to find the dominant method to reduce the power consumption in the wireless sensor network in order to stay works for long time and maintain the links with other nodes without loss of connection and transfer the information correctly. In this paper, a modified method was invented to minimize power utilization per data bit in a connection. This new method depends on the optimization process for reducing the power consumption as low as possible. All the tests of simulation process were done in additive white Gaussian noise (AWGN) channel. Numerical results demonstrated that the new method reduce the power when different values of noise are present with different types of modulation. Also the distance that the WSN will reach the information to it will be increase with presence of various noise amounts with different types of modulation. As a result, the power was decreased and the signal was reach more distance.

Copyright © 2019 Institute of Advanced Engineering and Science.
All rights reserved.

Corresponding Author:

Raad Farhood Chisab,

H.O.D Department of Electrical Techniques, Technical Institute-Kut,

Middle Technical University,

Al-Za'franiya, 10074 Baghdad, Iraq.

Email : raadfarhood@yahoo.com, Raad.FArhood@kti.mtu.edu.iq

1. INTRODUCTION

The WSN is a substructure included of detecting, calculating, and communication parts which provides a manager the facility to tool, detect, and respond to actions and occurrences in a definite location. The location may be the physical domain, a biotic scheme, or an "IT" structure. Sensor Network schemes are understood by spectators as a vital tool that will practice chief placement in the following next era for an excess of uses never the smallest being general safety [1]. In a sensor network four simple modules are exist: 1) a gathering of "distributed or localized sensors"; 2) a joining network (commonly, however not permanently, "wireless-based"); 3) a dominant location of info gathering; 4) a group of calculating incomes at the essential space to dealing information association, occasion trend, and information mining [2]. In this context, the detecting and calculation nodes are well thought-out part of the "sensor network". Actually, selected of the calculating are complete within the net itself [3]. Due to the possibly great amount of information composed, algorithmic procedures for information controlling show a significant part in "sensor networks" [4].

The calculation and connection organization related with "sensor networks" is regularly particular to this situation and ingrained in the expedient and "application-based" landscape of these nets. Power of the Node or life of the battery is vital plan thoughtfulness [5]. Currently, sensors may be termed as "smart"

cheap node fitted out with several aboard sensing fundamentals. They are lower rate lower-energy released multi-functional sensors that are understandably homed to a vital “sink node” [6]. Sensors are a device that internet-worked through a sequence of multi-hops small-space little-energy wireless-communication associates. Overall, surrounded by the sensor space, WSNs service argument-concerned with arbitrary-contact channel allocation and broadcast methods that are currently combined within “IEEE 802 family” of principles; truly, that methods are initially industrialized in the last 1960s specifically for wireless environs and for great groups of detached nodes with restricted channel-organization cleverness. Still, additional channel organization methods are besides existing [7]. Figure 1 shows the simple parts of the WSN system and demonstrates how can deals with it using the internet and how users can benefit from the data that it provides to the system. Figure 2 shows the general protocol stack that is used in WSN and what is the benefit of each stack. The protocol stack consists of five layers which are: “Upper layers, Transport, Networking, data Link layer and finally physical layer”. WNs normally communicate data to gathering positions that collective selected or totally of the info. WSNs have sole features, for example, however not restricted to, energy restrictions and restricted battery lifetime for the WNs, dismissed information gaining, short responsibility period, and, several to single streams [8]. The aim of WSN designer is to improve a wireless networking resolution that maintenances lower and near to middle information amounts. This design will have little energy ingesting. This design will also have assurances safekeeping and dependability. The location of “sensor nodes” never predetermined, letting arbitrary placement in unreachable lands or vibrant circumstances; still, this also show that “sensor network protocols” should have auto-organizing abilities [9].

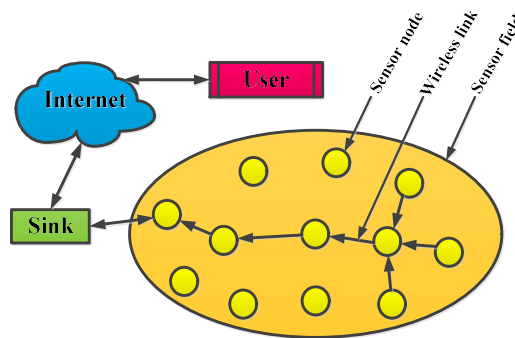

Figure 1. The simple construction of WSN

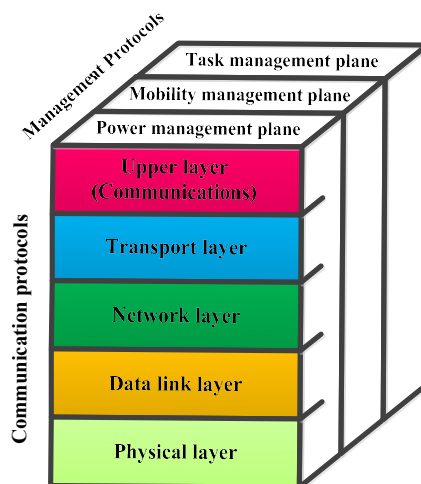

Figure 2. The general sensor networks protocol stack

2. THE USES OF WSN

Habitually, the network of wireless sensors is usage within situation of “high-end applications” like radioactivity and “nuclear-threat detection systems”, “over-the-horizon” defense detection for boats, and so on. A small list of using the sensors can be summarized as in the fields of :-“Military applications, Monitoring inimical forces, Monitoring friendly forces and equipment, Military-theater or battlefield surveillance, Targeting, Battle damage assessment, Nuclear, biological, and chemical attack detection, Environmental applications, Microclimates, Forest fire detection, Flood detection, Precision agriculture, Health applications, Remote monitoring of physiological data, Tracking and monitoring doctors and patients inside a hospital, Drug administration, Elderly assistance, Home applications, Home automation, Instrumented environment, Automated meter reading, Commercial applications, Environmental control in industrial and office buildings, Inventory control, Vehicle tracking and detection, Traffic flow surveillance” [10-15].

3. HARDWARE AND SOFTWARE STRUCTURE

In the wireless sensor network and exactly when need to study the behavior of this network we need to study the components of software and hardware. In Figure 3 it can be notice the overall component of design for hardware components. In Figure 4 the general component of software in WSN is appear and this is different for company to other which depends on using the types of WSN. The general hardware component is mainly consisting from power, Computational logic and storage, Sensor transducers and Communication. While the WSN is consist from software components which are: Operating system (OS), Sensor drivers, Communication processors, Communication drivers, Data processing mini-apps. The general components of software in WSN consists from operating system, actuator, storage, memory, location finding system, communication radio and other components such as drivers to complete the function of software part of WSN [16].

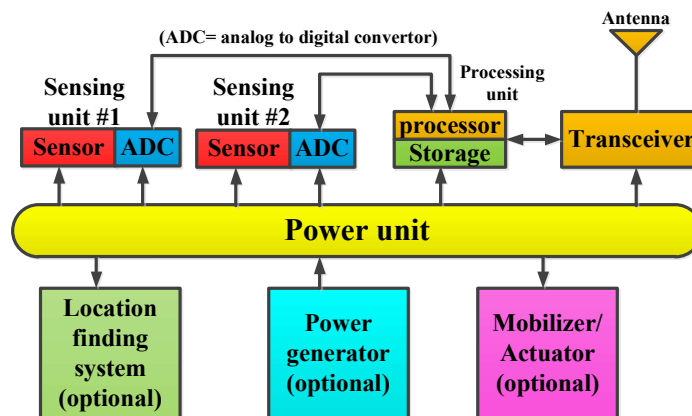

Figure 3. The common hardware components of WSN

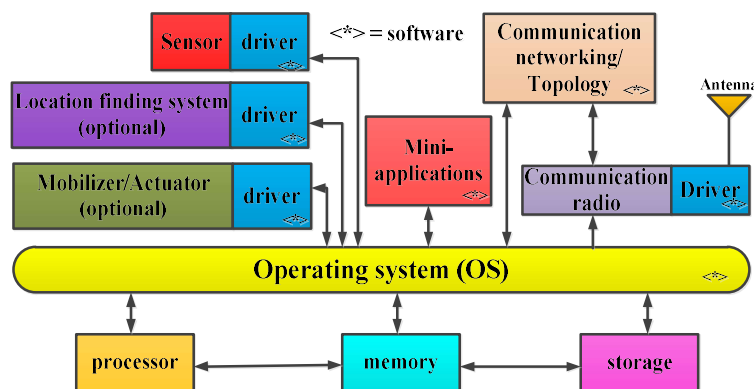

Figure 4. The common software components of WSN

4. THE MODEL OF PACKET STRUCTURE AND OVERALL SYSTEM

The structure of the information packet is displayed within Figure 5. It contains of four modules: “payload, upper layer header, PHY/MAC-header, and preamble”. It is existent LL bit within payload for every packet. Within “upper layer header” there is “control information” additional by “the upper layers”. These are “routing information, packet ID”. Also be existent the LUH bit in the “upper layer header”. It can be seen from the point of the “PHY and MAC layers the payload and the upper layer header are indiscernible”. So, these two parts are “modulated and coded” equally [17]. On the other hand, “PHY and MAC headers” are a previous defined modulation structure, like BPSK for an un-coded scheme and “coded BPSK” for a coded structure. This is done for the purpose of that “PHY and MAC headers” transmit significant control info, like info concerning “modulation and coding” for the “payload and the upper layer header”. So, the mapping type of the “PHY/MAC-header” will become strong and recognized to the receiver previously [18]. Therefore, receiver will continuously de-mapping the income “PHY/MAC-header”. So, it is not important what mapping structure the “payload and upper layer header” usage. Lastly, “the preamble” is a definite previous well-defined order that works for the determination of harmonization, formation of the “automatic gain controller (AGC)”. The distance and period factors for these modules are itemized in Table 1.

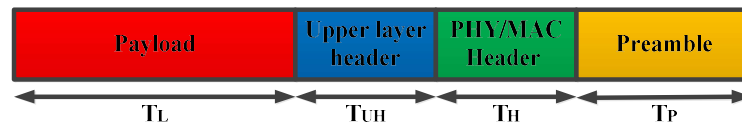

Figure 5. The construction of the information packet

Table 1. The Construction Factors for Information Packet

Packet parts	Span (bits)	Time (s)	Mapping type
“Preamble”	-	T_P	-
“PHY/MAC header”	L_H	T_H	Binary phase shift keying
“Upper layer header”	L_{UH}	T_{UH}	Adaptive modulation
“Payload”	L_L	T_L	Adaptive modulation

5. THE MODEL OF TRANSMITTER AND RECEIVER

In a sensor node, power is expended for detecting, information treating and communicate between nodes. In this manuscript, only the power ingesting within the process of communication is measured, because the power ingesting of detecting and information treating never disturb that optimization system and is typically insignificant. In transmitter terminal, power ingesting caused by the spread power and the power spent in the device. In receiver terminal, the lone power ingesting is that of the circuit. To enable the investigation of the power ingesting, we assuming universal “transmitter and receiver” simulations which are presented in Figure 6 and Figure 7.

5.1. Transmitter

As shown in Figure 6, the most important part of the power overwhelms within the component are: “DAC, LPF, BPF, mixer, synthesizer and PA”. It will be regard the power sinks in these parts are fixed. But only the power delivered to PA will be defined as:

$$W_{PA} = \beta W_{total} \quad (1)$$

Where W_{total} represented the total transmitted power. $\beta = \frac{\varepsilon}{\rho} - 1$

Where ε is the “peak to average ratio”. Also ρ is the “drain efficiency”

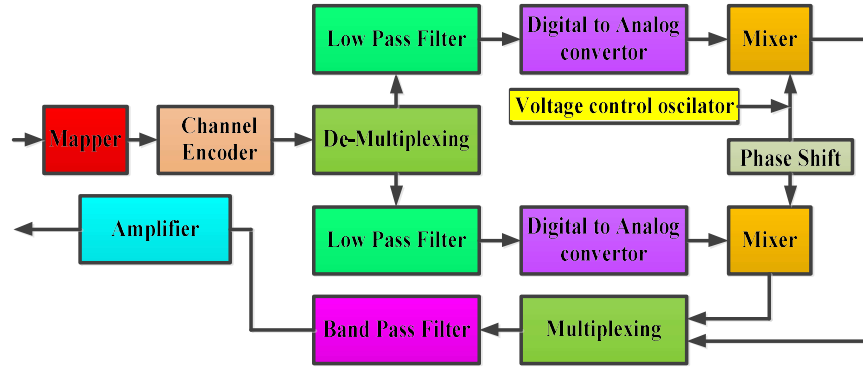

Figure 6. Spreader or “Transmitter” construction by Direct Mapping

5.2. Receiver

As shown in Figure 7, the most important parts from the receiver that overwhelms power are: “ADC, LPF, LNA, mixer, synthesizer, LFA and decoder”. The power delivered to “LPF, LNA, mixer, and synthesizer” will be regard as fixed.

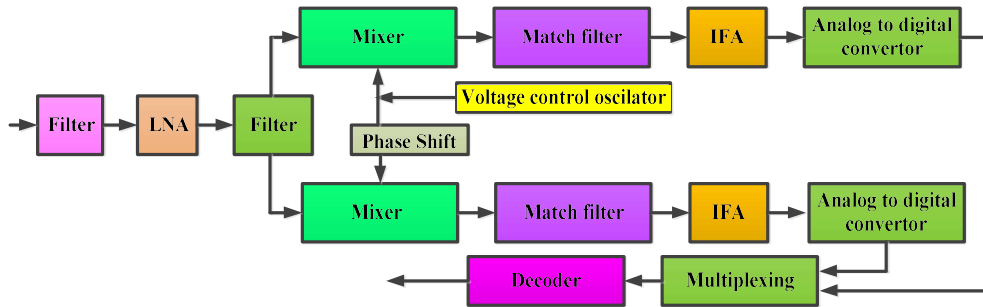

Figure 7. Receiver construction by direct De-Mapping

6. THE POWER CONSUMPTION MINIMIZATION PROSES

Within this manuscript the transmitter with the receiver regarded as stable for the time equal to T_s in seconds. It is assumed that $T_s = \frac{T_L + T_{UH} + T_H}{R_c} + T_p$ where R_c is the “rate for channel code”. For un-code case the value of R_c is set to one. So, the entire power feeding that needs to transfer or obtains “ L_L data bits” is:

$$W = \left(\frac{W_t}{G_c} + W_{AMP} + W_c \right) T_{on} \tag{2}$$

It can be shown that W_t represents the power transmitted in case of un-coded scheme. While G_c is the gain of the coding process. $W_{PA} = \beta W_t$ represents the power sinks in the power amplifier. Finally, W_c is regarded as the power delivered for the parts of the sending and receiving circuits. The power that is spread W_t is calculated by the SNR γ in a receiver and the probability of error in bits P_b . The magnitude γ can be defined as $\gamma = \frac{W_r}{2BN_0}$. In this equation the W_r represents the received power while B represents the bandwidth of the signal. The quantity N_0 represents the spectral power density of an additive white Gaussian noise channel. It can also find $\gamma = f(P_b)$ using the equation of “exponential approximation” of the “Q-function”.

In addition, by depending on the equations of signal propagation it can be seen that $W_t = GW_r$. The value G is approximate equal to $G \sim d^{3.5}$ and it is denote to path loss. So, the W_t can be calculated by $W_t = 2BN_0G\gamma$. It can be seen that the power dissipated inside the circuit for the sending and receiving end is equal to:

$$W_c = 2W_{mix} + 2W_{syn} + W_{fil} + W_{DAC} + W_{LNA} + W_{ADC} + W_v \tag{3}$$

where :

W_{mix} Denote to power dissipated inside the mixer.

W_{syn} Denote to power dissipated inside the frequency synthesizer.

W_{fil} Denote to power dissipated inside the filters.

W_{DAC} Denote to power dissipated inside the digital to analog convertor.

W_{LNA} Denote to power dissipated inside the low noise amplifier.

W_{ADC} Denote to power dissipated inside the analog to digital convertor.

W_v Denote to power dissipated inside the Viterbi decoder.

The amount of the W_{mix} , W_{syn} , W_{fil} and W_{LNA} are regarded as stable and not more changed while the value of W_{DAC} , W_{ADC} and W_v are calculated through the experiments and it is variable for each cases. So, the power consumption is:

$$W = \frac{(1+\beta)2T_{on}G\gamma N_0 B}{G_c} + W_c T_{on} \quad (4)$$

7. PACKET OPTIMAZATION FOR POWER DISSIPATED

In this part more than one assumption will be assumed. The first assumption is that the error in the PHY/MAC header is neglected. This assumption is regarded because the “length of the packet body is bigger than PHY/MAC header”. Therefore, the error extra occurs in packet body. The second reason for our assumption of no error is that the forceful type of modulation that is used in the PHY/MAC-header. Therefore, the error is seldom occurring in PHY/MAC-header. The more important thing that when the error is occurred within received packet then the process of retransmission is done. Now, the “probability of error” within packet occurs in the packet that containing L_L data

$$P_{pe} = 1 - (1 - P_b)^{L_L + L_{UH}} \quad (5)$$

In this paper more than one consideration is taken. First one is that the process of retransmission is works. Second, the “inter packet space IPS” is regarded as 5ms. Also take up the procedure of transmission and process of receiving will take the time equal to T_{tr} second to change from the “off (sleep)” condition to the “on (active)” condition. Third, the period for the “frequency synthesizer” to turn on was fixed and it was equal to 5 μ s. fourth, the power ingesting during T_{tr} , W_{tr} was around equal to W_{syn} . The value of W_{syn} represents the power ingesting in “frequency synthesizer”. Also the value T_{on} represent the period of transmission of unique packet. The period which is known as “ T_{ACK} is the period when the transmitter waiting for the acknowledgment from the receiver”. This value which is $T_{ACK} \approx \frac{L_H}{BR_c} + T_P$. The powers delivered for every limit are defined as:

$$W_{tr} = W_{syn} T_{tr} \quad (6)$$

$$W_{IPS} = W_{syn} T_{IPS} \quad (7)$$

$$W_{LN} = (W_{cr} - W_v) T_{ACK} \quad (8)$$

$$W_{ACK} = W_{cr} T_{ACK} \quad (9)$$

$$W_{tx} = \left[\frac{(1+\beta)2BN_0G\gamma}{G_c} + W_{ct} \right] T_{on} \quad (10)$$

$$W_{tx}^{ACK} = \left[\frac{(1+\beta)2BN_0G\gamma}{G_c} + W_{ct} \right] T_{ACK} \quad (11)$$

$$W_{rx} = W_{cr} T_{on}. \quad (12)$$

It can be noticed that the good providing unique packet with total amount of transmission was “m”. at the beginning the “m-1” broadcast the power intake through T_{ACK} in the spreader was W_{LN} . This assumption because there is no necessity to receives response from receiver. In the final providing, the power ingesting through the T_{ACK} time at the transmitter is W_{ACK} . There is also one important assumption is that the through the “inter-packet space T_{IPS} ” just the “frequency synthesizer” participate for power ingesting. W_{tx}^{ACK} Represents the power ingesting for transferring the acknowledgment at the time when receives the final

packet “ m^{th} packet”. Also, there is important assuming which is in time for first T_{ACK} , the power ingesting at the receiver is nil. So, the entire transmission and receiving power ingesting for the (m) sends are:

$$W_t(m) = (2W_{IPS} + W_{tx} + W_{LN})(m - 1) + 2W_{tr} + 2W_{IPS} + W_{tx} + W_{ACK} \quad (13)$$

$$W_r(m) = (2W_{IPS} + W_{rx})m + 2W_{tr} + W_{tx}^{ACK} \quad (14)$$

So, in order to effectively provide a packet, then “the average power” ingesting is:

$$\bar{W} = \sum_{i=1}^{\infty} [W_t(i) + W_r(i)P_r\{m = i\}] \quad (15)$$

It can be noticed that the amount (m) represents the account of broadcasts. The amount of $P_r\{m = i\}$ represents the possibility when the account of broadcasts equal to i . this equation was defined as $P_r\{m = i\} = P_{pe}^{i-1}(1 - P_{pe})$. Then some process for simplified the equation is done and will got the equations which is:

$$\bar{W} \approx \frac{(2W_{IPS} + W_{tx} + W_{LN})}{1 - P_{pe}} + 2W_{tr} + W_v T_{ACK} + \frac{(2W_{IPS} + W_{rx})}{1 - P_{pe}} + 2W_{tr} + EW_{tx}^{ACK} \quad (16)$$

So, the power ingesting per data bit is:

$$\bar{W}_{bit} = \frac{\bar{W}}{L_L} \quad (17)$$

In order to make the power \bar{W}_{bit} as minimum as possible it will makes the $\frac{\partial \bar{W}_{bit}}{\partial L_L} = 0$. This will give the result as:

$$A_1 L_L^2 + B_1 L_L + C_1 = 0 \quad (18)$$

Known as:

$$A_1 = \frac{W_{on} P_b}{B_{\eta}} \quad (19)$$

$$B_1 = P_b (4W_{IPS} + W_{LN} + W_{on} T_p + \frac{W_{on} L_H}{B_{R_c}} + \frac{W_{on} L_{UH}}{B_{\eta} R_c}) \quad (20)$$

$$C_1 = - \left(4W_{IPS} + W_{LN} + 4W_{tr} + W_{tx}^{ACK} + W_v T_{ACK} + W_{on} T_p + \frac{W_{on} L_H}{B_{R_c}} + \frac{W_{on} L_{UH}}{B_{\eta} R_c} \right) \quad (21)$$

Also it is known as:

$$W_{on} = \frac{2(1+\beta)BN_0G_{\gamma}}{G_c} + W_c \quad (22)$$

Using the (18) and when simplified it we will get the optimal quantity of data bits inside the “packet L_L ” then it will got (23).

$$L_L^* = -B_1 + \sqrt{B_1^2 - 4A_1 C_1} / 2A_1 \quad (23)$$

Similarly, the peak objective of P_b will be initiate by resolving the equation $\frac{\partial W_{bit}}{\partial P_b} \Big|_{L_L^*} = 0$. The final solution for optimal objective P_b will be create via the subsequent estimate.

$$P_b \ln P_b \approx P_b^{P_b} - 1 \quad (24)$$

$$P_b^{P_b} \approx -10P_b + 1 \quad (25)$$

So, at the time when apply the M-QAM, the result will be

$$P_b^* \approx \frac{1}{1+(L_L+L_{UH})[\ln_b^2+10+\frac{W_c T_{on}+4W_{IPS}+W_{LN}}{\frac{2}{3}(2^b-1)A_2}]} \quad (26)$$

Known that

$$A_2 = \frac{(1+\beta)2BN_0G(d)T_{on}}{G_c} \quad (27)$$

After assuming that the distance is approximately great. This lead to that $A_2 \approx \infty$ and the (26) will be equal to:

$$P_b^* \approx \frac{1}{1+(L_L+L_{UH})[\ln_b^2+1]} \quad (28)$$

So, the aim of errors probability in bit wills ultimately merging to the value exclusively calculated via the length of the information packet and the type of modulation. Therefore, when the value P_b^* merging this leads to that the value of L_L^* is also will merge for greater broadcast space.

8. RESULT AND DISCUSSIONS

In this paper there is more than one consideration that is used in simulation that is applied to resolve the problem of reducing the power dissipated in the WSN. These considerations are used to simplify the process of optimization and minimize all the calculation that is used in this paper. Some of these simplifications that are used are: “take a bandwidth of 25 KHz, $L_{UH}=240$ bits, $L_H=64$ bits, $T_P=55$ ms, $R_c=1/2$. Similarly, the packet length, L_L is restricted to 120 kilobytes”.

In this simulation six types of modulation are taken which are BPSK, QPSK, 8-PSK, 16PSK, 4-QAM, 16-QAM. Figure 8 shows the relation between the power consumption and specified amount of noise which is the multiplier of noise (N_0) with different type of modulation. It is shown that when the noise is small values like N_0 , $2N_0$ the value of power that is needed to transmit the data or information is lower and the power began to increased when the noise is increased. When try to examine the relation of modulation type with this curve it is shown that in case of BPSK gives lower power than other type with the same amount of noise N_0 and then 4-QAM and then 8-PSK. In this curve it can conclude that when noise is increased this means the power needed to transmit the information will have increased also but this relation is different for different values of modulation types. When we switch to Figure 9 it can be seen that this relation is the same which is between noise and power consumed but in this figure the optimization method was applied that used in this paper. It is noticed from Figure 9 that the value of power is less than that for Figure 8 with the same type of modulations. Therefore, it is concluded that this procedure of optimization is more benefit for reducing the power consumed that is need for transmit the information as compared with Figure 8 that has the same relation but without use the optimization method that is used in this paper.

Figure 10 and Figure 11 shows the relation between noise and the distance that the WSN can reach the information to it. In Figure 10, it can be seen that when the noise is equal to N_0 the distance about 6.5m but when the noise is increased ($2N_0$, $4N_0$, $8N_0$ and so on) then the distance will be decreased because the effects of noise on the ability of information to reach higher distance will be more until reach to 1m when the noise reach to value of $128N_0$. In Figure 11, it can be noticed that the same relation is satisfied but with the use of optimization technique and it is shown that the value of distance with the noise amount of N_0 is equal to 30m and this amount will be reducing when the noise is increase and reach to 9m when the noise raised until $128N_0$. it can be shows that the best or long distance that can be reach for broadcast can be got from the case when using the BPSK modulation type and then 4-QAM type then 8-PSK then 16QAM and finally the minimum case with 16-PSK

It is shown from Figure 12, which is explains the relation between the power transmitted with the distance that the WSN will reach it when transmit the signal, when the distance is very small (near zero meter) the power is very small which about $0.4 \cdot 10^{-5}$ W and this amount of power will increase with the distance increased until reach to $1.6 \cdot 10^{-5}$ W (these two value for the modulation type which is 4-QAM). It is shown that the changing of modulation type will effect on the power dissipated for signal and it is shown when the modulation is 4-QAM dissipate power less than from 16QAM or 8-PSK and also lower than 16-PSK. On the other hand, when using the optimization method as shown in Figure 13, the Power transmitted will be reduced with the same type of modulation as compared with the relation without optimization. For example, the power dissipated with the distance near to zero will be about $1.2 \cdot 10^{-7}$ W with modulation of 4-QAM.

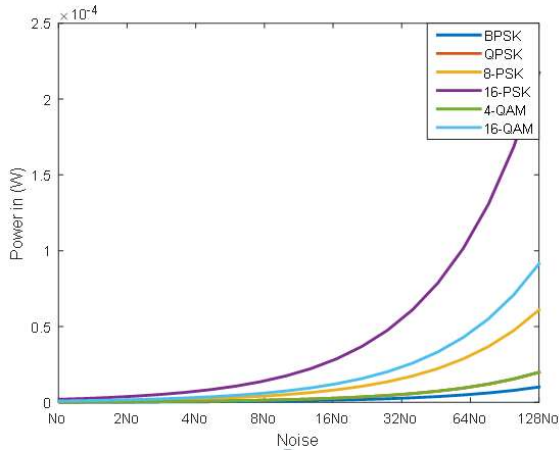

Figure 8. Relation between noise and power dissipated without minimization method

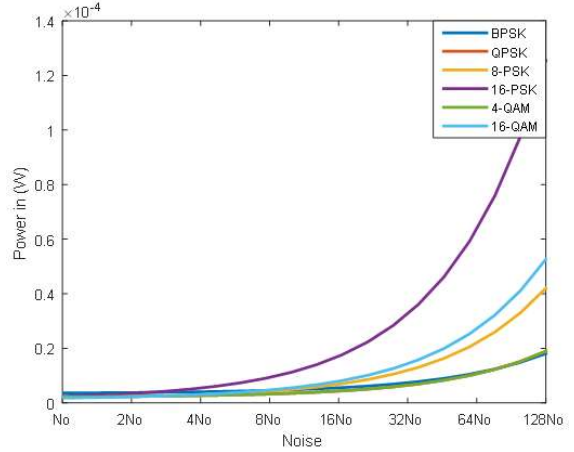

Figure 9. Relation between noise and power dissipated with minimization method

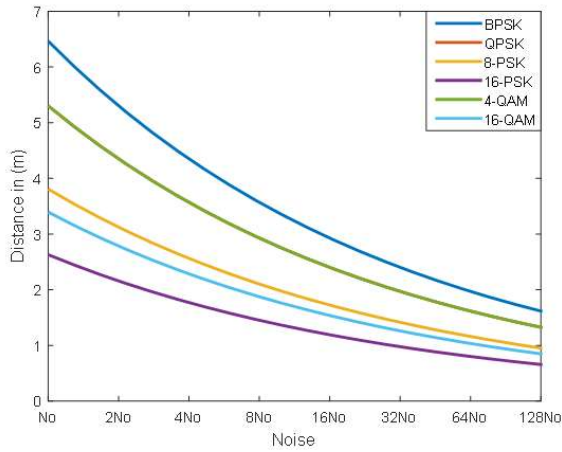

Figure 10. Relation between noise and distance without minimization method

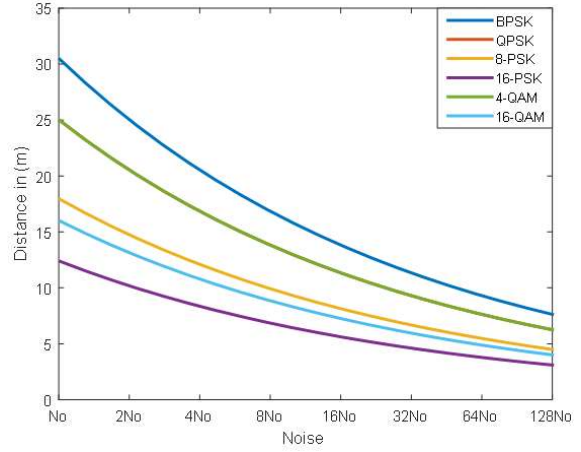

Figure 11. Relation between noise and distance with minimization method

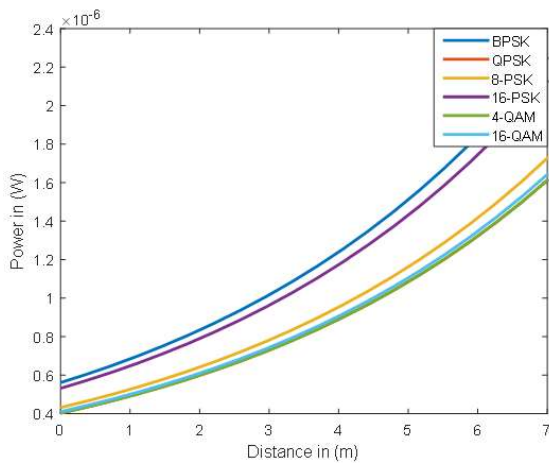

Figure 12. Relation between distance and power dissipated without minimization method

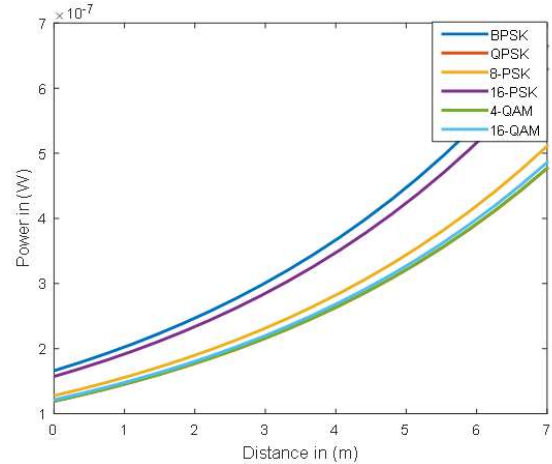

Figure 13. Relation between distance and power dissipated with minimization method

9. CONCLUSION

In this paper a strong method for optimization is done in which the power parameter is reduced for transmitted signal. Also using more than one types of modulation is done in order to show the variety of result according to changing the modulation and how it effects on the results such as power and distance with the presence of noise. It can be concluding that when the noise increases this lead to increase the power dissipated to transmit the power for the signal between the WSN. Also when the noise increases the distance that the signal will reached will be decreased because the noise effects on the efficiency of the signal therefore the distance will be decreased. On the other hand, it is concluded that when we need to transmit the signal to higher distance then need more power therefore when the distance increased lead to power increased also. All this examination for efficiency of the system is done with different types of modulation which are BPSK, QPSK, 8-PSK, 16-PSK, 4-QAM and 16-QAM. Therefore, we can notice more than one curve for each test. All previous tests are done with and without the optimization technique and can notice that when using the optimization, the power will be reduced and this will lead to monster benefit that is the long battery life and this is the target for all designers of WSN.

REFERENCES

- [1] K.K. Yap, V. Srinivasan, M. Motani, "MAX: Human-centric Search of the Physical World", in: *Proceedings of the Third International Conference on Embedded Networked Sensor Systems (Sensys)*, San Diego, CA, 2005.
- [2] I.Akyildiz, S.Weilian, Y. Sankarasubramaniam, and E. Cayirci, "A Survey on Sensor Networks," *IEEE Communications magazine*, vol. 40, pp. 102–114, Aug. 2002.
- [3] W. Heinzelman, A. Chandrakasan, and H. Balakrishnan, "An Application Specific Protocol Architecture for Wireless Microsensor Networks", *IEEE Transactions on Wireless Communications*, pp. 660–670, Oct. 2002.
- [4] O. Younis and S. Fahmy, "Distributed Clustering in Ad-Hoc Sensor Networks: A Hybrid, Energy-Efficient Approach", in *Proceedings of the 23rd Annual Joint Conference of the IEEE Computer and Communications Societies (INFOCOM)*, 2004
- [5] C. Schurgers, V. Tsiatsis, S. Ganeriwal and M. Srivastava, "Optimizing Sensor Networks in the Energy-Latency-Density Design Space", *IEEE Transactions on Mobile Computing*, pp. 70–80, Jan. 2002.
- [6] S. Cui, A. J. Goldsmith, and A. Bahai, "Energy-constrained Modulation Optimization", *IEEE Transactions on Wireless Communications*, vol. 4, no. 8, pp. 2349–2360, Sep. 2005.
- [7] Raad Farhood Chisab and C. K. Shukla, "Comparative Study in Performance for Subcarrier Mapping in Uplink 4G-LTE under Different Channel Cases", *International Journal of Advanced Computer Science and Applications (IJACSA)*, vol. 5, No. 1, 2014.
- [8] V. Raghunathan, C. Schurgers, P. Sung and M. Srivastava, "Energyaware Wireless Microsensor Networks", *IEEE Signal Processing magazine*, vol. 19, pp. 40–50, Mar. 2002.
- [9] K. Lorincz, D. Malan, T.R.F. Fulford-Jones, A. Nawoj, A. Clavel, V. Shnayder, G. Mainland, M. Welsh, S. Moulton, "Sensor Networks for Emergency Response: Challenges and Opportunities", *Pervasive Computing for First Response (Special Issue), IEEE Pervasive Computing*, October–December 2004.
- [10] Annapurna H S, M. Siddappa, "MTKD: An Algorithm for Multi-Tier Key Distribution for Securing Group Communication in WSN", *Institute of Advanced Engineering and Science (IAES), International Journal of Advances in Applied Sciences (IJAAS)*, ISSN 2252-8814, Vol 6, No 1, pp 23-31, 2017.
- [11] Lee ladhar annepu, "Cut Detection in Remote Versatile Wireless Sensor Mobile Networks", *Institute of Advanced Engineering and Science (IAES), international Journal of Advances in Applied Sciences (IJAAS)*, ISSN 2252-8814, Vol 3, No 4, PP 202-205, 2014.
- [12] K. Panimozhi, G. Mahadevan, "QoS Framework for a Multi-stack based Heterogeneous Wireless Sensor Network", *Institute of Advanced Engineering and Science (IAES), International Journal of Electrical and Computer Engineering (IJECE)*, ISSN: 2088-8708, Vol 7, No 5, DOI: <http://doi.org/10.11591/ijece.v7i5.pp2713-2720>, 2017.
- [13] Younes El Assari, Mounir Arioua, Imad Ez-zazi and Ahmed El Oualkadi, "Energy Performance of LDPC Scheme in Multi-Hop Wireless Sensor Network with Two Base Stations Model", *Institute of Advanced Engineering and Science (IAES), International Journal of Electrical and Computer Engineering (IJECE)*, ISSN: 2088-8708, Vol 7, No 2, DOI: <http://doi.org/10.11591/ijece.v7i2.pp933-941>, 2017.
- [14] Raad Farhood Chisab and C.K Shukla, "The Downlink 4G-LTE in Fading Channel Based on the Multiwavelet Transform", *IEEE Sixth International Conference on Computational Intelligence and Communication Networks (CICN)*, 14-16 Nov, 2014, pp 233-236, Available at: <http://ieeexplore.ieee.org/document/7065480/>, 2014.
- [15] I.F. Akyildiz, M.C. Vuran and O.B. Akan, "A Cross-layer Protocol for Wireless Sensor Networks", in: *Proceedings of the Conference on Information Science and Systems (CISS)*, 2006.
- [16] V. Rajendran, K. Obraczka and J.J. Garcia Luna Aceves, "Energy Efficient, Collision-free Medium Access Control for Wireless Sensor Networks", in *Proceedings of the First International Conference on Embedded Networked Sensor Systems (Sensys)*, Los Angeles, CA, 2003.
- [17] K. Seada, M. Zuniga, A. Helmy and B. Krishnamachari, "Energy-efficient Forwarding Strategies for Geographic Routing in Lossy Wireless Sensor Networks", in *Proceedings of the Sensys'04*, Baltimore, MD, 2004.
- [18] F. Liu, M.J.M. Rivera and X. Cheng, "Location-aware Key Establishment in Wireless Sensor Networks", in *Proceedings of the International Wireless Communications and Mobile Computing Conference (IWCMC)*, Vancouver, Canada, 2006.

BIOGRAPHIES OF AUTHORS

Dr. (Eng.) Raad Farhood Chisab was born in Baghdad-Iraq at 1975. He received the B.Sc. degree in Electrical Engineering and M.Sc. degree in Control and Computer Engineering from College of Engineering-University of Baghdad-Iraq. At 2015 the author gets his Ph.D. degree in Electronic and Communication Engineering from SHIATS University-INDIA. From 2005 the author works as lecturer, researcher and training supervisor in the Ministry of Higher Education and Scientific Research –Middle technical university-Iraq. He is working now as the head of electrical techniques department in technical institute–Kut–Middle technical university. His researchs interest includes signal processing, image processing, wireless communication, mobile technology, wireless sensor network, IOT and 5G Technology.