

A New Photovoltaic Energy Sharing System between Homes in Standalone Areas

A. Mezouari¹, R. Elgouri², M. Igouzal³, M. Alareqi⁴, K. Mateur⁵, H. Dahou⁶, L. Hlou⁷

^{1,3,4,5,6,7}Laboratory of Electrical Engineering & Energy Systems, Faculty of Science Ibn Tofail University, Morocco

²Laboratory of Electrical Engineering and Telecommunications Systems, National School of Applied Sciences (ENSA), Ibn Tofail University, Morocco

Article Info

Article history:

Received Mar 8, 2018

Revised May 31, 2018

Accepted Jul 29, 2018

Keyword:

Monitoring

Photovoltaic panels

Renewable energy sources

Solar energy sharing

Switching matrix

ABSTRACT

Today, global energy consumption is dominated by fossil fuels such as oil, coal and gas. The intensive consumption of these energy sources gives rise to greenhouse gas emissions and therefore an increase in CO₂ emissions. Photovoltaic energy has persistently been considered as a green and pollution-free renewable energy source to overcome greenhouse effect and energy crisis. This paper describes a new method of photovoltaic energy sharing in standalone micro-grids using photovoltaic panels. This approach is based on automatic electrical energy sharing depending on the state of charge (SOC) of the electrical storage unit using by each home and on the electrical power consumption of each home. The monitoring system is connected to each home in micro-grid, it manages each home's energy use, and assigns more energy to a large energy-consuming home. This architecture contributes to reducing total energy lost.

*Copyright © 2018 Institute of Advanced Engineering and Science.
All rights reserved.*

Corresponding Author:

Abdelkader Mezouari,

Engineering Laboratory of Electrical Engineering & Energy Systems,

Faculty of Science, Ibn Tofail University,

Kenitra, Morocco.

Email: mezouariabd@gmail.com

1. INTRODUCTION

In more recent years, the world is faced with climate change and forced to think of ways to reduce greenhouse gas emissions, renewable energy sources [1], [2] has gained momentum as an alternative to non-renewables and polluting sources such as oil, gas and coal. The solar energy has become one of popular way to power homes and buildings. Photovoltaic technology has advanced and made solar panels more flexible and easier to install. Solar power not only has the capacity to power an individual home, but even with a storage system there is often an excess of energy generated that can be exploit.

To go one-step beyond this, reseachers are developing the idea of sharing this excess energy with other homes within the community and starting microgrids for sharing the excess of electricity between homes in standalone areas. One of the biggest challenges with solar sharing is the unpredictability of photovoltaic system outputs and the difficulty of matching the energy demand and supply for consumers.

A number of previous studies have presented different methods of renewable energy sharing in microgrids to reduce total energy costs or avoid electrical energy waste [3]. An efficient energy sharing system [4] has been developed based on a cluster controller to share energy among homes. Energy is shared with other homes through additional DC power line. Each home is equipped with a photovoltaic system and an energy storage unit. Another study has proposed a distributed incentive-driven energy sharing system in a sustainable microgrid to solve the mismatch between energy generation and consumption in each home [5], [6]. It uses a common power line as an energy sharing media; an information line is used for ensure the communication between homes. The power switch is used to control energy sharing. Another solution, one

that brings a new approach to managing and optimizing distribution of electricity coming from the photovoltaic system in standalone micro-grids and recovering the maximum of electrical energy waste using a new system of electrical power mutualization between homes in standalone areas [7]. This approach draws upon the electrical energy required from each home. Moreover, it can respond to the high-energy requirements by each home in real time. The proposed system is used to control and share automatically the PV blocks among as many homes as possible.

The purpose of this work is to present a new approach of managing and optimizing the distribution of electrical energy coming from the photovoltaic panels between homes in standalone micro-grids. This approach is based on automatic photovoltaic energy sharing depending on the state of charge (SOC) of the electrical storage unit using by each home and on the electrical power consumption of each home. Moreover, the present architecture can limit the electrical energy waste and respond to the high-energy requirements by each home in real time. The proposed system is used to control and share automatically the PV panels among as many homes as possible. The rest of this paper is organized as follows: Section II introduces the photovoltaic energy sharing system (PVESS), the switch topology and discusses the PVES algorithm. Section III gives an overview of the system architecture. Section IV present the discussion and results. Finally, Section V concludes the paper.

2. PHOTOVOLTAIC ENERGY SHARING SYSTEM (PVESS) DESCRIPTION

2.1. Switching Matrix

The photovoltaic energy sharing (PVES) system is used to control and share automatically the PV panels or strings between homes in standalone areas. Figure 1 shows the synoptic of the photovoltaic energy sharing system, all homes are connected to the system, it manages the sharing of photovoltaic panels between two homes at least; each home is equipped with photovoltaic panels, electrical storage unit and DC/DC converter. The photovoltaic panels are connected to different homes load via a switching matrix. Figure 2 shows the interconnections between homes and different panels.

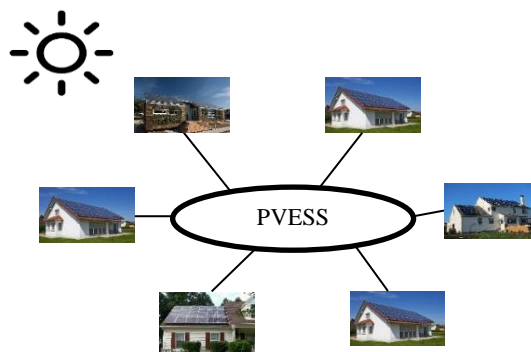

Figure 1. Synoptic Diagram of the photovoltaic energy sharing system in standalone microgrid

The switching matrix is composed by N_{sw} relays to allow a parallel combination between shared PV panels or strings and different, according to the topology shown in Figure 2.

$$N_{sw} = N_{pv} * N_h \quad (1)$$

Each PV panel will have to be connected to any other string of any home. Thus, the positive terminal of a PV panel will be connected to the positive terminal of any other string. Likewise, the negative terminal will have a means of connecting to the negative terminal of any other string. However, for the reconfiguration system used, only $(N_{pv} * N_h)$ switches will be utilized to reconfigure the PV panels connection. N_h is the number of homes in standalone microgrid and N_{pv} is the number of photovoltaic panels such:

$$N_{pv} = \sum_{U=1}^{N_h} N_p(U) \quad (2)$$

$N_p(U)$: is the number of personal blocks of each home.

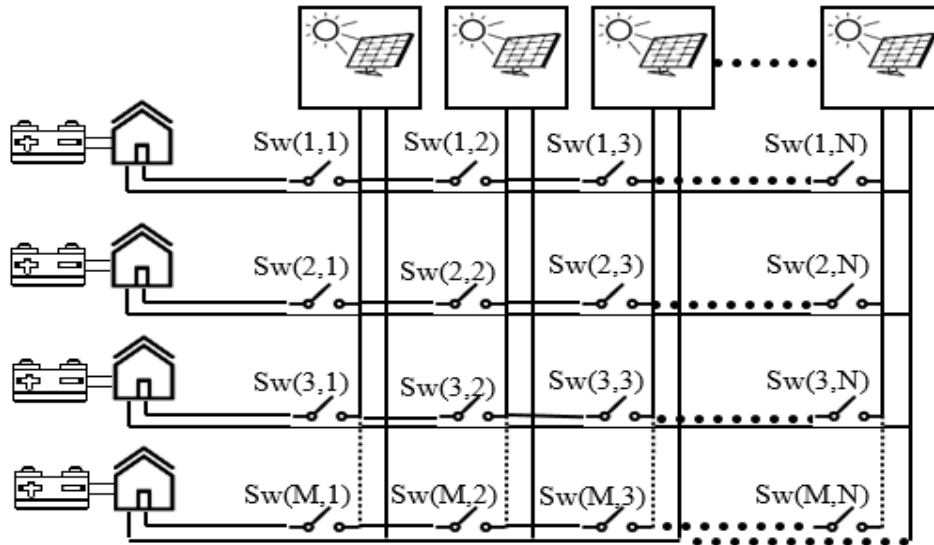

Figure 2. Schematic Diagram of the PVBM Switching Matrix

2.2. PVES Algorithm

To control the switching matrix and generate the adequate PV panels configuration. An algorithm of PV panels sharing is developed in order to reconfigure the PV panels and connect them in parallel with the different homes in standalone micro-grid, depending on the state of charge of the electrical storage unit using by each home and on the electrical power requirement of each home. The proposed algorithm applies to N_{pv} number of photovoltaic panels and N_h number of homes.

This algorithm is developed so that any home, in case of trouble, can connect at least to his personal PV panels. Figure 3 shows the flowchart of the algorithm implemented in the microcontroller for controlling the switching matrix. The proposed algorithm consists in reacting instantly following the change of the input variables (the state of charge of the electrical storage unit using by each home and on the electrical power requirement of each home) and calculates the optimal configurations of the switching matrix according to the following steps:

Step 1: Identify the total number of homes (N_h) in standalone microgrid and the number of personal PV panels (N_p) of each home.

Step 2: calculate the electrical power consumption (P_h) of the first home (k), estimate his battery state of charge (SOC) and detecte the number of free PV panels (Bank). According to this three parameters, the PVES algorithm responds as follows:

- In the case where the battery of this home (k), is fully charged and his electrical power consumption is less than the maximum power provided by one PV panel (P_{pv}). The PVES algorithm subtracts all the PV panels connected to this home (k) and adds them to the Bank (construct the reserve of PV panels to share them with other homes ($k \neq k$)). Then the algorithm passes to the next home.
- In the case where the battery of this home (k), is fully charged and his electrical power consumption is greater than the maximum power provided by one PV panel P_{pv} . The PVES algorithm passes to the next user ($k + 1$).
- In the case where the battery of this home (k) is discharged, the PVES algorithm tests the reserve of free PV panels dedicated to the sharing with other homes (the Bank). Two cases are possible:
 1. If the number of the home (k) personal PV panels ($N_p(k)$) is strictly greater than the number of instantaneous connected PV panels ($N_h(k)$) to this home: The PVES algorithm searches for another user ($k \neq k$) which uses a number of PV panels greater than the number of his own PV panels. The control device subtracts a block from the home k' and adds it to the home k . Then the PVES algorithm passes to the next home ($k + 1$).
 2. If the number of the personal PV panels ($N_p(k)$) to the home (k) is less than or equal to the instantaneous number of connected blocks ($N_h(k)$) to this user: the PVES algorithm passes to the next user ($k + 1$).

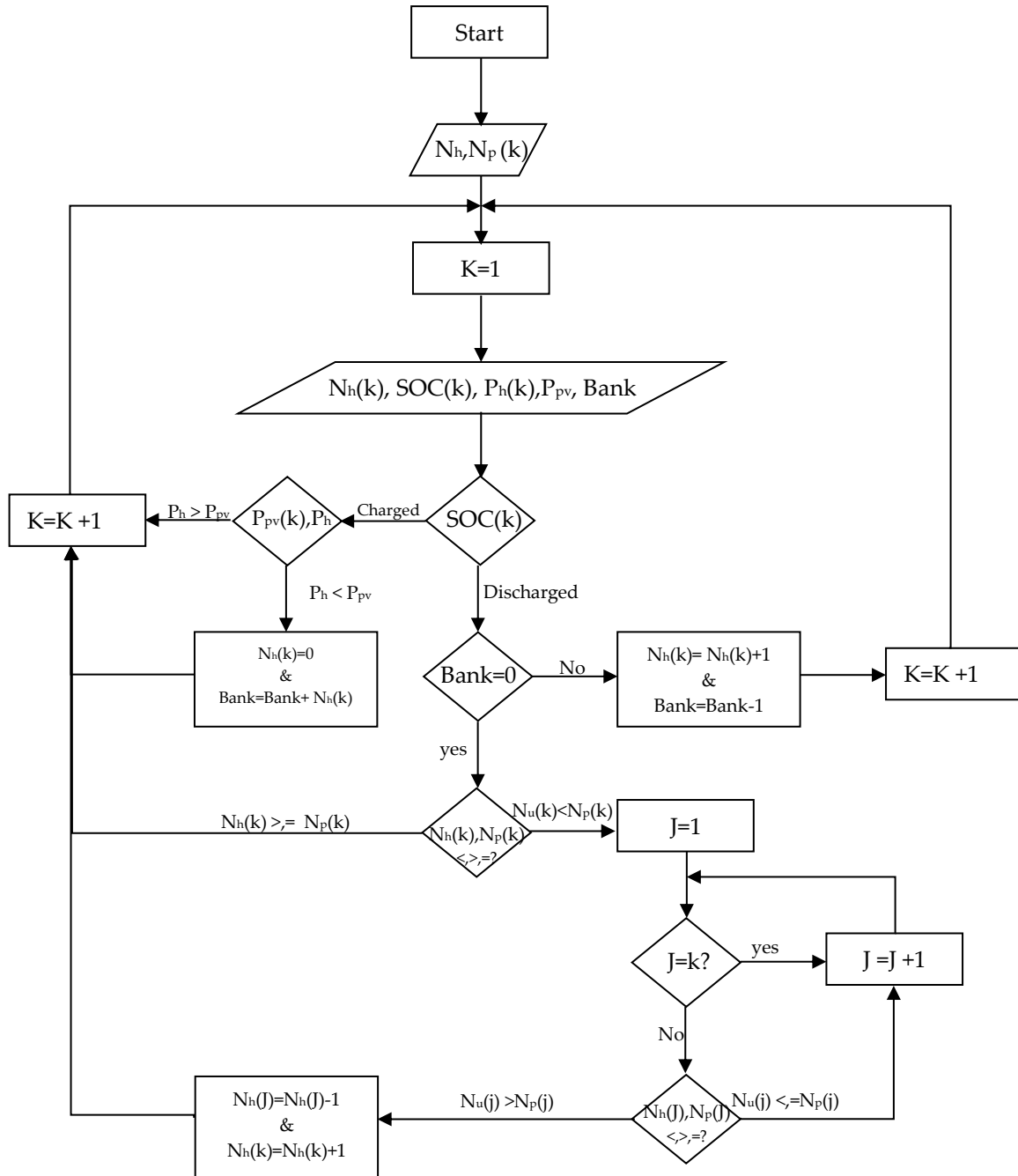

Figure 3. Flowchart of PVES algorithm

3. PVES SYSTEM OVERVIEW

In this section, we briefly overview the system architecture and introduce the hardware architecture to achieve photovoltaic energy sharing among multiple homes in standalone microgrid. The proposed energy sharing system uses electronic devices to control the energy sharing among homes. The PVES collects information (battery SOC and electrical power consumption) from homes and then arranges the PV panels sharing among homes.

3.1. Battery SOC Determination

The most used methods for state-of-charge (SOC) estimation in lead acid and lithium-ion battery are based on ampere-hour counting [8], estimation of the open-circuit-voltage (OCV) [9], impedance measurement [10], in particular the ohmic and the DC internal resistance of the cell. For each method, there

are advantages and drawbacks. In the PVES system, the method based on ampere-hour counting is used to estimate the SOC battery of each home.

The ampere-hour counting or balance charge is a sign conform measurement of the amount of balanced charge, which has been stored in or taken out of the cell, normed to the nominal capacity C_N . More exactly: The SOC of the battery at any hour t , $SOC(t)$, depends on the SOC at the previous hour $SOC(t-1)$. The following conditions need to be taken into consideration for energy flows from $(t-1)$ to t : At any given hour, the battery SOC will be given by the expression:

$$SOC(t) = SOC(t-1) + \eta_c P_c - \eta_d P_d \quad (3)$$

In which, η_c is the battery charging efficiency, and η_d is the battery discharging efficiency. The following general expression derived from (3) applies to the battery dynamics:

$$SOC(t) = SOC(0) + \eta_c \sum_{\tau=1}^t P_c(\tau) - \eta_d \sum_{\tau=1}^t P_d(\tau) \quad (4)$$

where $SOC(0)$ is considered as the initial SOC of the battery, the SOC at the time $t_0=0$. $\eta_c \sum_{\tau=1}^t P_c(\tau)$ is the power accepted by the battery at time t and $\eta_d \sum_{\tau=1}^t P_d(\tau)$ is the power discharged by the battery at time t . The available battery bank capacity must not be less than the minimum allowable capacity SOC_{min} and must not be higher than the maximum allowable capacity SOC_{max} [11] with:

$$SOC_{max} = (1 - DOD)SOC_{min}$$

where DOD is the depth of discharge expressed as a percentage.

3.2. System desiegn

The scenario proposed in this paper present standalone microGrid nodes in a small community with five homes. Where each home is equipped with two PV panels (100W), battery (12V / 700Ah) and DC/DC inverter for charge controlling. In this embodiment, all PV panels are able to be share with other homes, which makes ten blocks are permanently shared between the five homes. As shown in Figure 4 the different component of PVES system communicate between them using a programmable electronic board. In order to be able to distribute the PV panels on the different homes and to process all possible configurations, the switching matrix consists of fifty electronic relays connecting each home to the different PV panels. According to the topology described in Figure 2. The switches are controlled by an electronic board, which delivers a control voltage for each switch (5V closed relay, 0V open relay). In this system, a battery state of charge estimator is used for each home; a current sensor and a voltage sensor are installed at the load terminals of each home to detect the electrical power consumption. The value of this power will be compared with a threshold value P_b equal to the maximum power delivered by one photovoltaic panel. An Arduino, FPGA board or a nother programmable electronic board is used as controlling and processing unit to implement the method of PVES managing according to the steps described in the flowchart of Figure 3.

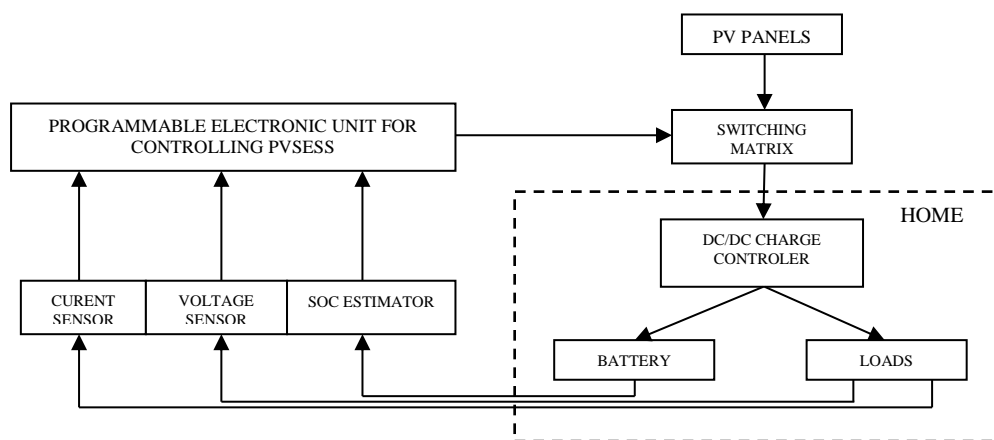

Figure 4. The PVES system component

4. RESULTS AND DISCUSSION

According to the example of scenario presented in this paper, Table 1 summarizes during one month the daily electrical power consumption of each home in standalone microgrid, the percentage of days with a fully charge batteries, the percentage of days with discharged batteries and the average value of electrical energy wasted due to a fully charge of the batteries.

Table 1. Random scenario of electrical power consumption of five homes during one month with and without using PVESS

Homes	Daily avrege consumption [Wh]	percentage of days with fully charged batteries %		percentage of days with discharged batteries %		electrical energy wasted (Daily avrege) [Wh]	
		Without Using PVESS	Using PVESS	Without Using PVESS	Using PVESS	Without Using PVESS	Using PVESS
Home 1	760	0	45	20	5	222	50
Home 2	700	29	75	0	0	291	36
Home 3	498	79	95	0	0	439	25
Home 4	760	0	40	35	15	186	5
Home 5	199	100	100	0	0	700	55

In this typical scenario and during one month, Figure 5 presents the comparison between the amount of electrical energy lost by each home in the standalone microgrid, with and without using the photovoltaic energy sharing system. According to Figure 6, the PVESS can recover and share more than 97% of exceeded electrical energy produced by the home 4 and more than 90% of electrical energy produced by all homes on the microgrid, compared to standalne homes equipped with a conventional photovoltaic system.

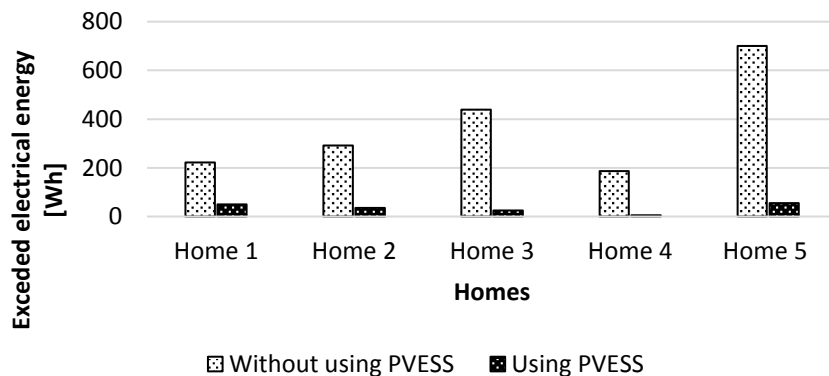

Figure 5. Electrical energy lost produced by each home with and without using PVES system

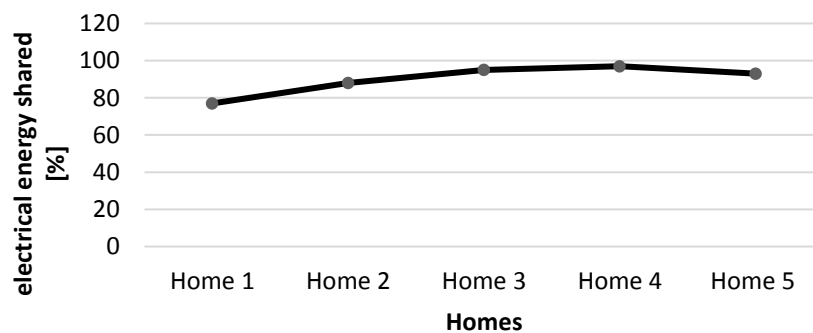

Figure 6. Percentage of electrical energy surplus shared by each home

Thus, the PVES method presented in this paper allows recovery of maximum electrical energy waste and share it with other homes in micro-grid. In addition, proposed system can serve as a basis for analysing and managing critical situations, not treated by the photovoltaic blocks mutualization system, described in the paper [7]. The PVBM system does not take into account the state of charge of the batteries. Which causes:

- The batteries of any home can totally discharged after the mutualization process.
- Decreasing the number and length of battery discharge, which affect a battery's ability to deliver power.

In addition, the systems of photovoltaic energy sharing that does not take into account the SOC of the batteries, increases the total number of charge/discharge cycles and decreases the battery life. Finally, the PVES system described in this paper proposes a decreasing in the number of DC/DC inverter compared to the PVBMS.

5. CONCLUSION

This paper, proposes a new system of photovoltaic energy sharing in standalone micro-grids using photovoltaic panels. This proposed system is based on automatic electrical energy sharing, depending on the state of charge (SOC) of the electrical storage unit using by each home and on the electrical power consumption of each home. The electrical sharing system is connected to each home in micro-grid, according to the topology of switching matrix developed in this paper. It manages each home's energy use, and assigns more energy to a large energy-consuming home. This architecture contributes to reducing total energy lost. We also developed a consumer energy sharing algorithm to minimize consumers' electrical lost and improve the energy sharing efficiency.

REFERENCES

- [1] Muruganantham B., *et al.*, "Challenges with renewable energy sources and storage in practical distribution systems," *Renewable and Sustainable Energy Reviews*, vol. 73, pp. 125-134, 2017.
- [2] Kodanda R. and Mannam V., "Operation and Control of Grid Connected Hybrid AC/DC Microgrids using RES," *International Journal of Power Electronics and Drive Systems*, vol/issue: 5(2) pp. 195-202. 2014.
- [3] Bounthan B., *et al.*, "Optimal Generation Scheduling of Power System for Maximum Renewable Energy Harvesting and Power Losses Minimization," *International Journal of Electrical and Computer Engineering (IJECE)*, vol/issue: 8(4) pp. 1954-1966. 2018.
- [4] T. Zhu, *et al.*, "Sharing renewable energy in smart microgrids," *ACM/IEEE International Conference on Cyber Physical Systems, Philadelphia, USA*, pp. 219-228, 2013.
- [5] W. Zhong, *et al.*, "iDES: incentive-driven distributed energy sharing in sustainable microgrids," *International Green Computing Conference, Dallas, USA*, pp. 1-10, 2014.
- [6] V. Kiray, *et al.*, "A modeling study of renewable and stored energy sharing and pricing management system developed for multi-apartment complexes," *IEEE PES innovative smart grid technologies Europe*, Istanbul, Turkey, pp. 1-6, 2014.
- [7] A. Mezouari, *et al.*, "A New Photovoltaic Blocks Mutualization System for Micro-Grids Using an Arduino Board and Labview," *International Journal of Power Electronics and Drive Systems (IJPEDS)*, vol/issue: 9(1), pp. 98-104, 2018.
- [8] K. S. Ng, *et al.*, "Enhanced Coulomb counting method for estimating state-of-charge and state-of-health of lithium-ion batteries," *Applied Energy*, vol/issue: 86(9), pp. 1506-1511, 2009.
- [9] J. Chiasson and B. Vairamohan, "Estimating the state of charge of a battery," *IEEE Transactions on Control Systems Technology*, vol/issue: 13(3), pp. 465-470, 2005.
- [10] S. Rodrigues, *et al.*, "A review of state-of-charge indication of batteries by means of A.C. impedance measurements," *Journal of Power Sources*, vol/issue: 87(1-2), pp. 12-20, 2000.
- [11] S. Vosen and J. Keller, "Hybrid energy storage systems for standalone electric power systems: optimization of system performance and cost through control strategies," *International Journal of Hydrogen Energy*, vol/issue: 24(12), pp. 1139-1156, 1999.

BIOGRAPHIES OF AUTHORS

Abdelkader Mezouari, 29 years old, is a fourth year doctoral student, and member of laboratory electrical engineering and energy systems, Ibn Tofail University, Kenitra, Morocco received his master degree in microelectronics in 2013.



Rachid Elgouri is professor in National School of Applied Sciences (ENSA), Ibn Tofail University, Kenitra, Morocco. His research interests in electrical engineering and renewable energy include the modeling and design optimization of renewable energy systems, the development of microelectronic energy systems and power electronic converters for renewable energy sources applications and the development of sensors and electronic measurement systems and information security.



Mohammed Alareqi was born in Taiz, Yemen in 1974. He received the B.S in Applied physics from university of technology, Baghdad, Iraq and M.S degree in microelectronics in 2010 from university of ibn tofail, Kenitra, Morocco. He is PHD student and staff member of laboratory electrical engineering and energy systems, Ibn tofail university, Kenitra Morocco.



Khalid Mateur received his master degree in microelectronics in 2011, now he is PHD student and member of laboratory electrical engineering and energy systems, Ibn tofail university, Kenitra Morocco.



Hamad DAHOU master degree and phd student, Member of Electrical Engineering and Energy Systems Laboratory



Laamari Hlou is director of Laboratory electrical engineering and energy systems, Ibn tofail university, Kenitra Morocco. His research interests in electrical engineering and renewable energy include the modeling and design optimization of renewable energy systems, the development of microelectronic energy systems and power electronic converters for renewable energy sources applications and the development of sensors and electronic measurement systems and information security.