

## Investigation and Analysis of Space Vector Modulation with Matrix Converter Determined Based on Fuzzy C-Means Tuned Modulation Indexs

Ch. Amarendra, K. Harinadh Reddy

Department of Electrical and Electronics Engineering, K. L. University, India

---

### Article Info

#### Article history:

Received Apr 28, 2016

Revised Jul 10, 2016

Accepted Jul 29, 2016

---

#### Keyword:

Matrix Converter  
Direct Space Vector  
Modulation  
Indirect Space Vector  
Modulation  
Fuzzy c-Means (FCM)

---

### ABSTRACT

Matrix converter performs energy conversion by directly connecting input phases with output phases through bidirectional switches. Conventional power converters make use of bulky reactive elements which are subjected to ageing, reduce the system reliability. The matrix converter (MC) stands as an alternative to conventional power converter. Furthermore MC's provide bidirectional power flow nearly sinusoidal input and sinusoidal output waveform and controllable input power factor. In this work, three modulation methods have been simulated using MATLAB and compared on the basis of input current harmonics, output voltage harmonics and number of switching per cycle. The three techniques simulated are, Optimal Venturini method, Direct Space Vector Modulation (DSVM) and Indirect Space Vector Modulation (ISVM) on Conventional Matrix Converter (CMC) and obtained form Fuzzy c-Means (FCM). DSVM with FCM is proposed for obtaining best results compared to other three techniques.

Copyright © 2016 Institute of Advanced Engineering and Science.  
All rights reserved.

---

### Corresponding Author:

Ch. Amarendra,  
Research scholar, Department of Electrical and Electronics Engineering,  
K. L. University,  
Green fields, Vadeswaram, Guntur.  
Email: amarendraamrita@gmail.com

---

## 1. INTRODUCTION

The matrix converters are one stage converters capable of providing sinusoidal voltage and frequency transformation. Each output line is linked to each input line via a bidirectional switch. These bidirectional switches provides to acquire voltages with variable amplitude and frequency at the output side by switching input voltage with various modulation algorithms. The matrix converter is a single stage converter which has an array of  $m \times n$  bidirectional power switching to connect directly;  $m$ -phase voltage source to  $n$ -phase load. The matrix converter of  $3 \times 3$  switches shown in Figure 1 has highest practical interest because it connects a three phase voltage source with a three phase load.

Normally, the matrix converter is fed by a voltage source and, for this reason the input terminals should not be shorted. On the other hand the load has typically an inductive nature and for this reason an output phase must never be opened. Defining the switching function of a single switch:

$$S_{kj} = \begin{cases} 1 & \text{switch } S_{kj} \text{ closed} \\ 0, & \text{switch } S_{kj} \text{ open} \end{cases} \quad K = \{A, B, C\} \quad j = \{a, b, c\} \quad (1)$$

The restriction is expressed as

$$S_{Aj} + S_{Bj} + S_{Cj} = 1 \quad j = \{a, b, c\} \quad (2)$$

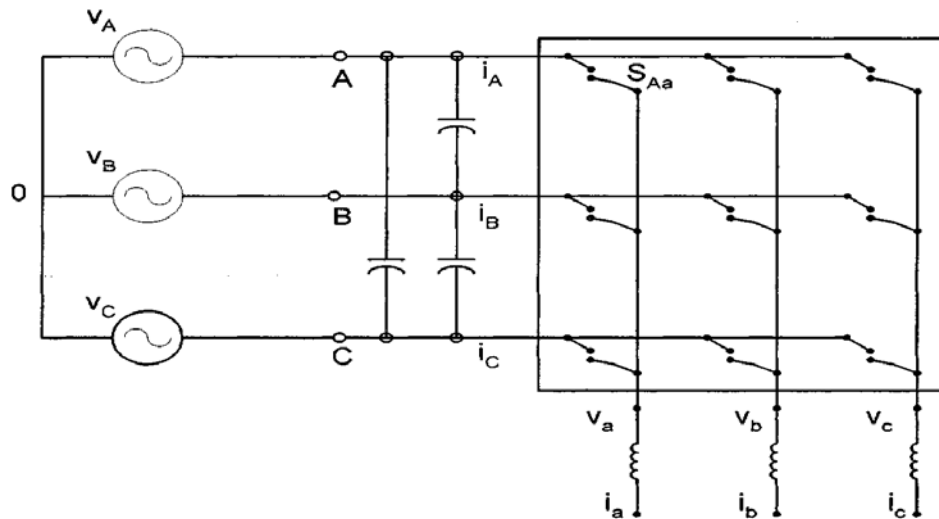

Figure 1. 3×3matrix converter topology

The input and output voltage can be expressed as vectors defined by

$$V_o = \begin{bmatrix} v_a(t) \\ v_b(t) \\ v_c(t) \end{bmatrix} \quad V_i = \begin{bmatrix} v_A(t) \\ v_B(t) \\ v_C(t) \end{bmatrix} \quad (3)$$

The input and output current can be expressed as vectors defined by

$$I_i = \begin{bmatrix} i_a(t) \\ i_b(t) \\ i_c(t) \end{bmatrix} \quad I_o = \begin{bmatrix} i_A(t) \\ i_B(t) \\ i_C(t) \end{bmatrix} \quad (4)$$

The relationship between load and input voltage can be expressed as

$$\begin{bmatrix} v_a(t) \\ v_b(t) \\ v_c(t) \end{bmatrix} = \begin{bmatrix} S_{Aa}(t) & S_{Ba}(t) & S_{Ca}(t) \\ S_{Ab}(t) & S_{Bb}(t) & S_{Cb}(t) \\ S_{Ac}(t) & S_{Bc}(t) & S_{Cc}(t) \end{bmatrix} \begin{bmatrix} v_A(t) \\ v_B(t) \\ v_C(t) \end{bmatrix} \quad (5)$$

By considering that the bidirectional power switches work with high switching frequency, a low-frequency output voltage of variable amplitude and frequency can be generated by modulating the duty cycle of the switches using their respective switching function.

Let  $m_{kj}(t)$  be the duty cycle of switch  $S_{kj}$  defined as  $m_{kj}(t) = t_{kj} / T_{seq}$ . Which can have the following values

$$0 < m_{kj} < 1 \quad k = \{A, B, C\}, \quad j = \{a, b, c\}. \quad (6)$$

The Alsina and Venturini Method (AV Method) is the first to produce sinusoidal input and output wave forms with minimal higher order harmonics and no sub harmonic components. The most popular switching algorithm is space vector modulation that allows the control of input current and output voltage vectors independently. Space vector Modulation has many advantages with respect to AV and Optimal AV modulation techniques, such as obtain maximum voltage transfer ratio ( $0 < q' < 0.866$ ) without adding third harmonics, minimize the number of switching operations per cycle. These three modulations for Matrix Converter have been proposed in literature [1]-[4]. Many aspects such as Total Harmonic Distortion (THD), complexity of implementation and number of switching operations per cycle play an important role in determining an appropriate modulation strategy.

## 2. ALESINA – VENTURINI METHOD (AV METHOD)

A first solution is obtained by using the duty cycle matrix approach. This strategy allows the control of the output voltages and input power factor, and can be summarized in the following equation, valid for unity input power factor.

$$m_{kj} = \frac{t_{kj}}{T_{seq}} = \frac{1}{3} \left[ 1 + \frac{2v_k v_j}{v_{im}^2} \right] \quad \text{for } k=A,B,C \text{ and } j=a,b,c \quad (7)$$

Assuming balanced supply voltages and balanced output conditions, the maximum value of the voltage transfer ratio 'q' is 0.5. This low value represents the major drawback of this modulation strategy.

## 3. ALESINA - VENTURINI 1989 (OPTIMUM AV METHOD)

In order to improve the performance of the previous modulation strategy in terms of maximum voltage transfer ratio, a second solution has been presented in [2],[3]. In this case the modulation law can be described by the following relationship, valid for unity power factor, and maximum voltage transfer ratio 'q' is 0.866.

$$m_{kj} = \frac{1}{3} \left[ 1 + \frac{2v_k v_j}{v_{im}^2} + \frac{4q}{3\sqrt{3}} \sin(\omega_i + \beta_K) \sin(3\omega_i t) \right] \quad (8)$$

for  $K=A, B, C$  and  $j=a, b, c$   $\beta_K = 0, 2\pi/3, 4\pi/3$  for  $K = A, B, C$  respectively.

## 4. DIRECT SPACE VECTOR MODULATION (DSVM)

The DSVM has following advantages compared to AV Method and Optimal AV Method  
a. Maximum voltage transfer ratio (0.866) without utilizing the third harmonic component injection method.  
b. Reduce the effective switching frequency in each cycle, and thus the switching losses.  
c. Minimizing the input current and output voltage harmonics. At any switching time, there are 27 switching for connecting output phase to input phases. These switching combinations can be analyzed in three groups, Group I - Each output phase is directly connected to three input phases inters with six switching combinations. Group II - There are 18 switching combinations in the second group active voltage vector formed at variable amplitude and frequency. Amplitude of the output voltage depends on the selected input line voltages. Group III - Last group with three switching combinations consists of zero vectors. In this case, all the output phases are connected to the input phase. Output line voltage and input current space vectors are used in the application of the Space Vector Modulation (SVM) to the matrix converter. The duty cycle for the four non-zero vectors

$$\delta_1 = (-1)^{k_o+k_i+1} \frac{2m \cos(\theta'_o - \frac{\pi}{2}) \cos(\theta'_i - \frac{\pi}{2})}{\sqrt{3} \cos(\Delta\theta)} \quad (9)$$

$$\delta_2 = (-1)^{k_o+k_i} \frac{2m \cos(\theta'_o - \frac{\pi}{2}) \cos(\theta'_i + \frac{\pi}{6})}{\sqrt{3} \cos(\Delta\theta)} \quad (10)$$

$$\delta_3 = (-1)^{k_o+k_i} \frac{2m \cos(\theta'_o + \frac{\pi}{6}) \cos(\theta'_i - \frac{\pi}{2})}{\sqrt{3} \cos(\Delta\theta)} \quad (11)$$

$$\delta_4 = (-1)^{k_o+k_i+1} \frac{2m \cos(\theta'_o + \frac{\pi}{6}) \cos(\theta'_i + \frac{\pi}{6})}{\sqrt{3} \cos(\Delta\theta)} \quad (12)$$

Where  $m$  is the modulation index,  $\Delta\theta$  is the displacement angle measured between input voltage vector  $V_i$  and input current vector  $I_i$ ,  $k_v$  and  $K_i$  are the voltage and current sectors respectively.

$$\theta'_o = \theta_o - (k_v - 1) \frac{\pi}{6} \quad (13)$$

$$\theta'_i = \theta_i - (k_i - 1) \frac{\pi}{6} \quad (14)$$

If the sign of any duty cycle is negative then the vector of group II must have a negative sign. The duty cycle of the zero vector  $V_{so}$  and  $I_{so}$  is such that the total duty cycle must be the unit at a fixed sampling frequency.

$$\delta_0 = 1 - \delta_1 + \delta_2 + \delta_3 + \delta_4 \quad (15)$$

Table 1. Position switching vectors of group 2 in terms of the voltage and current sectors, for each non-zero vector

Current Sector	Voltage Sector											
	1 or 4			2 or 5				3 or 6				
1 or 4	9	7	3	1	6	4	9	7	3	1	6	4
2 or 5	8	9	2	3	5	6	8	9	2	3	5	6
3 or 6	7	8	1	2	4	5	7	8	1	2	4	5
	$S_1$	$S_2$	$S_3$	$S_4$	$S_1$	$S_2$	$S_3$	$S_4$	$S_1$	$S_2$	$S_3$	$S_4$

## 5. Indirect Space Vector Modulation (ISVM)

This modulation technique applies the well developed Pulse Width Modulation (PWM) strategies of converter to a matrix converter modulation algorithm. The objective is still the same as direct space vector. Synthesize the output voltage vectors from the input voltages and the input current vector from the output currents. The output voltages and input currents are controlled independently in ISVM. The advantage of this modulation scheme is that it is easier to implement the well established PWM converter modulation to the MC. As the matrix converter can equivalently be represented as inverter and rectifier stages split by a fictitious DC link this is done by dividing the switching functions into the product of rectifier and inverter switching function. Two space vector modulations for current source rectifier and voltage source inverter stages should be implemented and then the two modulation results should be combined.

$$\begin{bmatrix} S_{11} & S_{21} & S_{31} \\ S_{12} & S_{22} & S_{32} \\ S_{13} & S_{23} & S_{33} \end{bmatrix} = \begin{bmatrix} S_7 & S_8 \\ S_9 & S_{10} \\ S_{11} & S_{12} \end{bmatrix} \cdot \begin{bmatrix} S_1 & S_3 & S_5 \\ S_2 & S_4 & S_6 \end{bmatrix} \quad (15)$$

$$\begin{bmatrix} V_A \\ V_B \\ V_C \end{bmatrix} = \begin{bmatrix} S_7 & S_8 \\ S_9 & S_{10} \\ S_{11} & S_{12} \end{bmatrix} \cdot \begin{bmatrix} S_1 & S_3 & S_5 \\ S_2 & S_4 & S_6 \end{bmatrix} \cdot \begin{bmatrix} V_a \\ V_b \\ V_c \end{bmatrix} \quad (16)$$

### 5.1. SVM for the rectifier stage

The rectifier part of the equivalent circuit can be assumed as a current source rectifier with the averaged value of  $I_{dc}$  and is represented as follows

$$I_{dc} = \frac{\sqrt{3}}{2} I_{out} \cdot m_v \cdot \cos(\theta_{out}) \quad (17)$$

$I_{out}$  is the peak value of output current  $\theta_{out}$  is the output load displacement angle and  $m_v = V_{out}/V_{dc}$ . The input current space vector  $I_{ref}$  is extracted as

$$I_{ref} = \frac{2}{3} (I_a + \alpha I_b + \alpha^2 I_c) \quad (18)$$

The nine rectifier switches have nine permitted combinations avoid an open circuit at the DC-link. These combinations include three zero and six non zero input currents. The reference input current vector is synthesized by impressing the adjoining switching vectors ( $I_\gamma$ ) and ( $I_\delta$ ) with duty cycle ( $d_\gamma$ ) and ( $d_\delta$ ) respectively.

$$I_{ref} = I_\gamma \cdot d_\gamma + I_\delta \cdot d_\delta \quad (19)$$

The duty ratios of active vectors are

$$d_\gamma = \frac{T_\gamma}{T_s} = m_c \sin\left(\frac{\pi}{3} - \theta_i\right) \quad (20)$$

$$d_\delta = \frac{T_\delta}{T_s} = m_c \sin(\theta_i) \quad (21)$$

$$d_{OC} = \frac{T_{OC}}{T_s} = 1 - d_\delta - d_\gamma \quad (22)$$

Where  $\theta_i$  indicates the angle of the reference current vector. The current modulation index  $m_c$  defines the desired current transfer ratio such as

$$m_c = \frac{I_{ref}}{I_{DC}}; 0 \leq m_c \leq 1$$

## 5.2. Fuzzy C-Means for SVM

The classification of modulation indexes are obtained in rectifier and inverter of MC was fine-tuned and clustered with help of Fuzzy c-Means. The fine-tuned modulation indexes ( $m_c$ ,  $m_v$ ) for purpose of SVM. The detailed algorithm with Fuzzy c-Means as follows

### Algorithm (step by step)

1. Fix "c" i.e,  $2 \leq c \leq n$  and initialize partition matrix

$$U^{(0)} \in M_c$$

Where U with "c" rows and "n" columns

2. Calculate the c centre vector,  $v_i^{(r)}$  using following equation

$$V_{ij} = \frac{\sum_{k=1}^n (\mu_{ik})^2 X_{kj}}{\sum_{k=1}^n (\mu_{ik})^2} \quad (23)$$

Where  $i=1,2,\dots,c$ ,  $j=1,2,\dots,n$ ,  $\mu_{ik}$  is the member ship function

3. Update  $U^{(r)}$  calculate updated characteristics function (for all i,k)

$$d_{ik} = \left[ \sum_{\substack{i=0,1,\dots,c \\ j=1,\dots,m \\ k=1,\dots,n}} (X_{kj} - V_{ij})^2 \right]^{\frac{1}{2}} \quad (24)$$

$X_{ik}$  is the input of SVM. Find membership value of partition matrix element

$$\mu_{ik}^{r+1} = \left[ \sum_{j=1}^c \left[ \frac{d_{ik}^r}{d_{jk}^r} \right]^{m^{1-1}} \right]^{-1} \quad (25)$$

Where  $m^1$ . weight factor

4. If  $\max [\mu_{ik}^1 - \mu_{ik}^0] \leq \epsilon$  (tolerance level) stop; otherwise set  $r=r+1$  and return to stop.

This fuzzy c-mean algorithm is used to fine tune the current modulation index  $m_c$ , voltage modulation index  $m_v$ . The proposed Fuzzy Based Space Vector Modulation is the novel modulation strategy for matrix converter.

## 6. SIMULATION RESULTS

In order to compare the performance of different modulation techniques applied to the matrix converter voltage source connected to electrical appliances in the field of domestic and industrial. In a simulation electrical appliance has considered as a practical RL specified branches. In this work, three modulation methods for Matrix Converter have been simulated on MATLAB/simulink and compared on the basis of input current harmonics, output voltage harmonics and number of switching operations per cycle. The simulation diagram as shown in the Figure 2 to 3, the output voltage waveforms, input current waveforms and THD analysis were shown in Figure 4 to 8. FCM is used in both ISVM and DSVM.

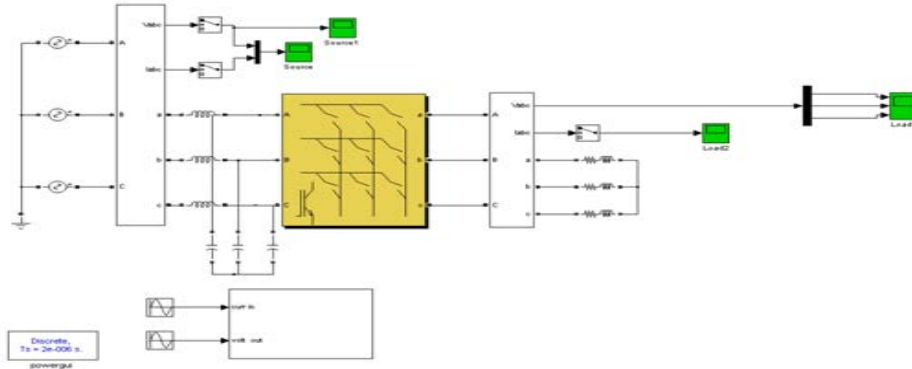

Figure 2. matrix converter simulink diagram

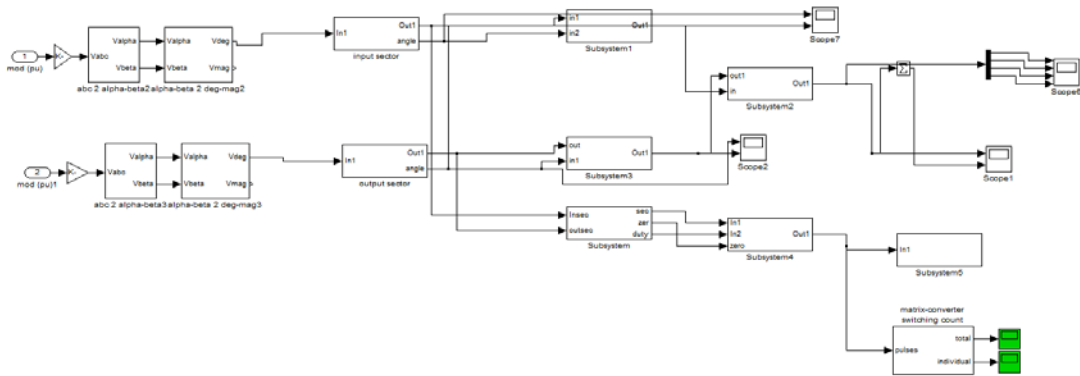

Figure 3. Direct SVM subsystem for switching pulse generation

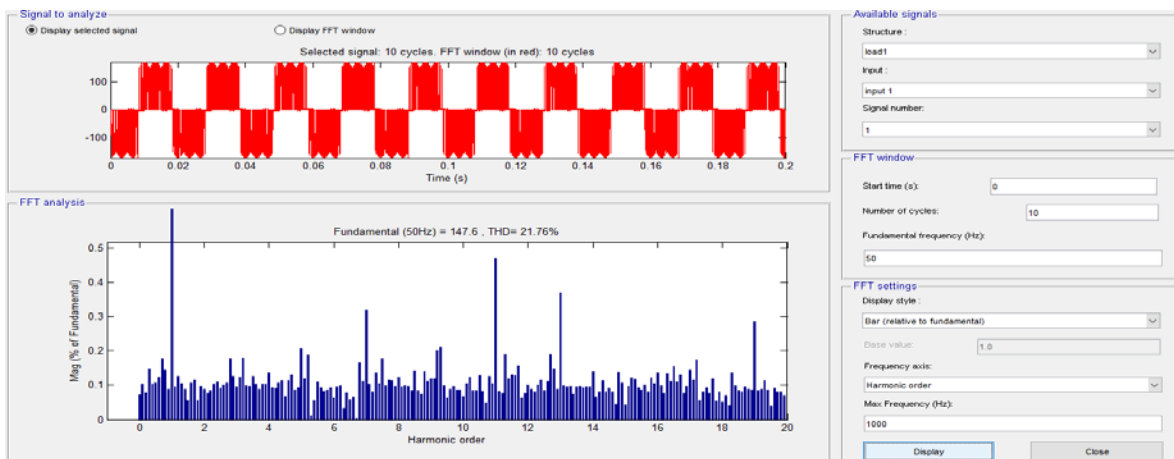

Figure 4. ISVM with FCM Output Voltage THD analysis

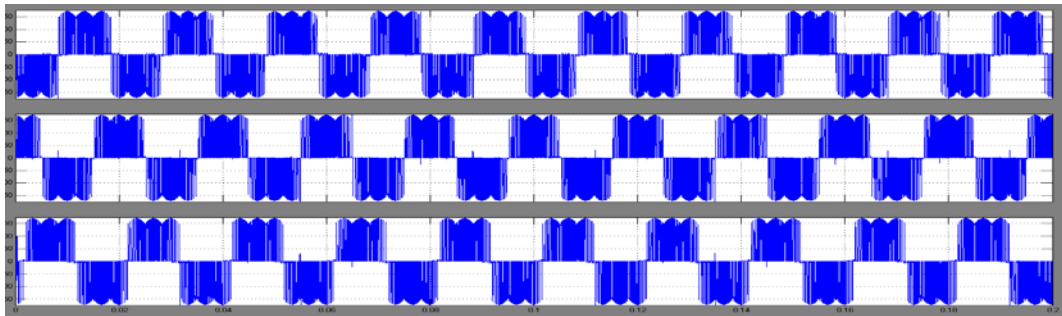

Figure 5. DSVM output volatge waveform

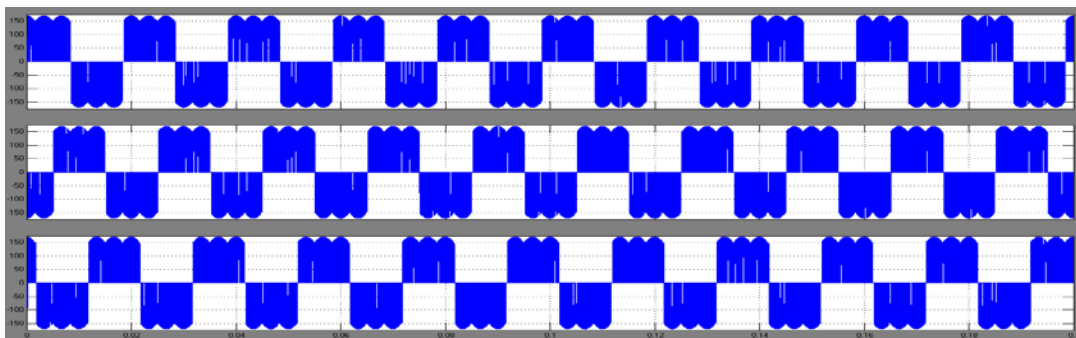

Figure 6. ISVM with FCM output volatge waveform

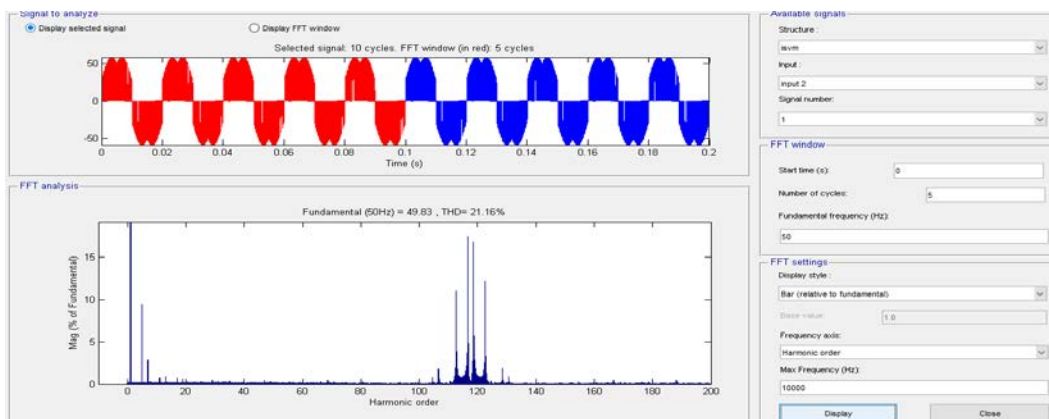

Figure 7. ISVM with FCM input current harmonics

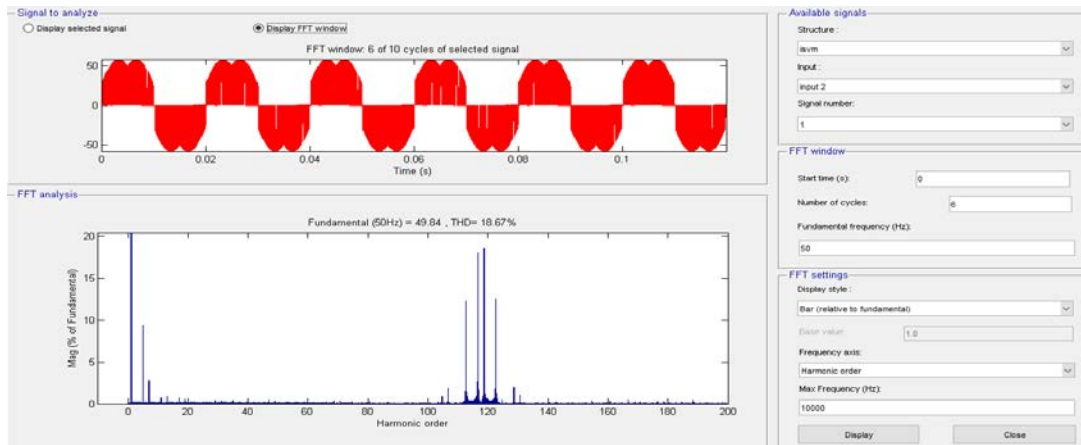

Figure 8. DSVM with FCM input current harmonics

The test parameters are presented in Table 2. The simulations were performed in MATLAB/simulink, the summary of result were tabulated in Table 3.

Table 2. Test case system parameters

PARAMETERS	VALUE
Source voltage (peak)	100
System frequency	50Hz
Load Resistance	10ohms
Load Inductance	10 $\mu$ H
Switching frequency	2.5KHz
Modulation index	0.866

Table 3. Results Summary

Modulation Techniques	Optimal AV Method	ISVM with FCM	DSVM with FCM
Input Current Harmonics	29.63	21.16	18.67
Output Voltage Harmonics	34.55	21.76	20.26
Number of Switching Operations per Cycle	105	85	91

## 7. CONCLUSION

Matrix Converter with simple RL load has been simulated with Direct Space Vector Modulation reduced the input current THD by “9%“, output voltage THD by “14%” from the results of Optimal AV method. Switching operations per cycle for DSVM is more compare to ISVM and Optimal AV method this is because of the better utilization of zero switching states .Eventhough DVSM results more switching operations per cycle compare with the other methods, in THD point of view DSVM gives the best results compared with other two methods with fine tuning of madulation indexes in both inverter and rectifier stages.

## NOMENCLATURE

$V_a(t), V_b(t), V_c(t)$ -	Output Voltages
$V_A(t), V_B(t), V_C(t)$ -	Input Voltages
$I_a(t), i_b(t), i_c(t)$ -	Output Currents
$i_A(t), i_B(t), i_C(t)$ -	Input Currents
$m$	Modulation Index
$\delta$	Duty ratio
$\theta_{out}$	Output load displacement angle
$K_i, K_v$	Input current sector, Output voltage sector



## REFERENCES

- [1] M. Venturini and A. Alesina, "Generalised transformer: a new bidirectional, sinusoidal waveform frequency converter with continuously adjustable input power factor," in *the IEEE Power Electronics Specialists Conference (PESC '80)*, Atlanta, Ga, USA, pp. 242–252.
- [2] A. Alesina and M. G. B. Venturini, "Analysis and design of optimum-amplitude nine-switch direct AC-AC converters", *IEEE Transactions on Power Electrons*.
- [3] L. Huber and D. Borojevic, "Space vector modulated three phase to three-phase matrix converter with input power factor correction," *IEEE Transactions on Industry Applications*, vol/issue: 31(6), pp. 1234–1246, 1995.
- [4] Ch. Amarendra and P. V. Pattabhiram "Comparative study of DSVM and ISVM for matrix converter," *Indian Journal of Applied Research (IJAR)*, vol/issue: 3(6), 2016.

## BIOGRAPHIES OF AUTHORS



Ch. Amarendra was born in India on July 25, 1990. He received B.Tech Degree in Electrical and Electronics Engineering From Amrita School of Engineering in 2011, India. He completed M.Tech degree in Power Electronics and Drives from K. L. University in 2013, India. Presently he is a part time research scholar in K.L.University. His research interests include matrix converter, Particle swarm optimization, Electrical Drives and Poly phase Drives.



Dr. K. Harinadha Reddy was born in India on July 02, 1974. He received B.E. degree in Electrical and Electronics Engineering from K.U. in 1997, India. He completed M.Tech degree in Electrical Power Systems Emphasis High Voltage Engineering from J. N. T. University - Kakinada Campus in 2006, India. He obtained Ph. D degree in Electrical Power Systems from Andhra University Campus in the year 2012. At present he is working as Professor in Electrical and Electronics Engineering department at K L University, India. 10 papers are published in various national and international journals. His research interests include AI techniques and their applications to Power System, Electrical Drives, FACT devices and Integrated Renewable Energy Systems.