

Designing Framework for Standardization Case Study: Lithium-Ion Battery Module in Electric Vehicle Application

Wahyudi Sutopo¹, Evizal Abdul Kadir²

¹Department of Industrial Engineering, Faculty of Engineering, Sebelas Maret University, Surakarta, Indonesia

²Information Technology Department, Faculty of Engineering, Universitas Islam Riau, Pekanbaru, Riau 28282, Indonesia

Article Info

Article history:

Received Apr 6, 2017

Revised Jun 2, 2017

Accepted Jun 16, 2017

Keyword:

Battery module framework

Electric vehicle

Lithium-ion battery

Standardization

ABSTRACT

Standardization is one of the important things before to deploy a product. Regulation such as national standard has important roles in industry. The roles of standard such as ensuring safety for consumer and producer, increasing product competitiveness, and reducing trade barriers. Indonesia is currently in the stage of developing industry of electric vehicle, so that standard which is related to electric vehicle, one of it is standard for the electric vehicle battery. Besides that, Indonesia does not have a relevant standard to regulate. This study is intended to make a framework for standardization of lithium-ion battery module product using A Framework for Analysis, Comparison, and Testing of Standard (FACTS) approach. There are three stages in FACTS approach, they are analysis, comparison, and testing. Based on the result of this research, the framework of lithium-ion battery module product standard consists of 8 parameters.

*Copyright © 2018 Institute of Advanced Engineering and Science.
All rights reserved.*

Corresponding Author:

Wahyudi Sutopo,
Department of Industrial Engineering,
Faculty of Engineering,
Sebelas Maret University,
Surakarta, Indonesia.
Email: wahyudisutopo@gmail.com

1. INTRODUCTION

Global warming is one of the newest issues which are related to environmental damage. One of the causes of global warming is increasing amount of CO₂ emissions which are produced by fossil fuel. Therefore, most of people switch fossil fuel to green energy sources such as solar, wind, etc. Battery is one of green energy embodiments that can reduce the using of fossil fuels. It can efficiently store electricity in chemicals and release it according to demand [1], [2]. Electric vehicle is one of technologies that utilize battery as energy source and usually the battery which is used is rechargeable battery. The battery has huge effect for electric vehicle performance [3], [4]. Battery stores energy chemically, and convert chemical energy into electrical energy by electrochemical reaction [5], [6]. Battery is currently developed in various types, such as lead-acid battery, nickel metal hydride, nickel cadmium, lithium-ion battery etc. Each type of batteries has different performance and characteristic [6].

Currently, rechargeable lithium-ion batteries are under the consideration of an electrical vehicle because they have been showing good characteristic such as high energy density, long cycle life, high power density, stable voltage, no memory effect and environmental friendliness [7-9]. Countries which are recently excel in developing lithium-ion rechargeable battery for electric vehicle are US, China, Germany, Japan, and Korea [10]. The countries also dominate battery manufacture industry in Indonesia. They can be market leader easily in Indonesia because unavailability of lithium-ion rechargeable battery regulation or standard in Indonesia which can be used as reference to regulate all of things which are involved in battery industry.

Regulation such as national standard has important roles in industry, the roles such as:

- a. Ensuring safety for consumer and producer
- b. Increasing product competitiveness
- c. Reducing trade barriers

Process to establish a standard is called as standardization. Standardization is defined as process of formulating, defining, applying, maintaining, imposing, and supervising standard which is done orderly and involves roles of relevant stakeholders [11]. Standardization is done by government through a national standardization organization. In Indonesia, government regulates standard product through by national organization which is called National Standard Agency (BSN) [12].

Given the important roles standard and unavailability of lithium-ion battery standard for electric vehicle application, this research tried to figure out how to make a framework for standard of lithium-ion battery in electric vehicle by using FACTS approach. Standardization for lithium-ion battery in electric vehicle is done gradually, that means the standard is made for the smallest part to the whole battery system in electric vehicle. The whole battery system in electric vehicle consists of battery cell, battery module, battery pack, and battery management system. Figure 1 shows the detail of battery system of electric vehicle.

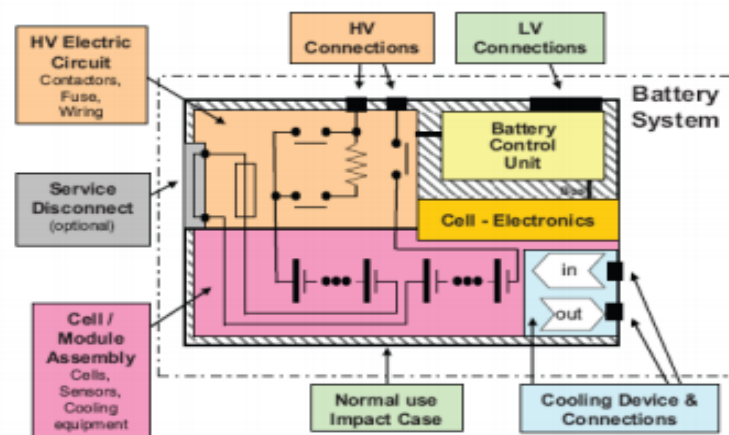

Figure 1. Battery system of electric vehicle [10]

Case of this research is how to make a framework for product standard of lithium-ion battery in electric vehicle especially in module level. According to IEC 62620, module battery is group of cells connected together either in a series and/or parallel configuration with or without protective devices (e.g. fuse or PTC) and monitoring circuitry [13], [14]. Every battery module in assembly process consists of battery cells, the cell to cell interconnection, and the battery cell insulation, sensors, the cooling components, the Battery Module Controller (BMC) and the housing [15]. Figure 2 shows the battery module product. The framework for standard of lithium-ion battery module is done by using FACTS approach (A Framework for Analysis, Comparison, and Testing of Standard). FACTS approach analyzes, compares, and tests standard [16]. This approach is partially based on the Zachman Framework, which is used to bridge the perceived gap between standards as developed by domain expert and those standards as understood by stakeholders [16].



Figure 2. Module battery product [17]

FACTS concept considers stakeholder requirements when designing standard framework, it is in line with BSN's consensus principle which considers relevant stakeholder opinions or requirements and does not side with a certain party or stakeholder to get the decision. Based on these, one of stages in FACTS namely, verification test is done by focus group discussion. In this research, the FGD involved the relevant stakeholders as participant.

2. RESEARCH METHOD

The object of this study is lithium-ion rechargeable battery which is used in electrical vehicle especially in module level. There are 3 stages in FACTS approach, they are analysis, comparison, and testing. The detail stages in FACTS can be seen in Figure 3. The analysis consists of a stakeholder and technical analysis [16]. The stakeholder analysis must be done to get stakeholder's requirements. Each stakeholder may also have multiple perspectives, for examples a manufacturing company can be either a buyer or a producer [16]. After doing stakeholder analysis, the next step which is done in stage of analysis is technical analysis. The technical analysis is intended to convert stakeholder's requirements into technical requirements by using Zachman framework which is used 6 based questions and they are What, How, When, Where, Who and Why (5W1H) [16].

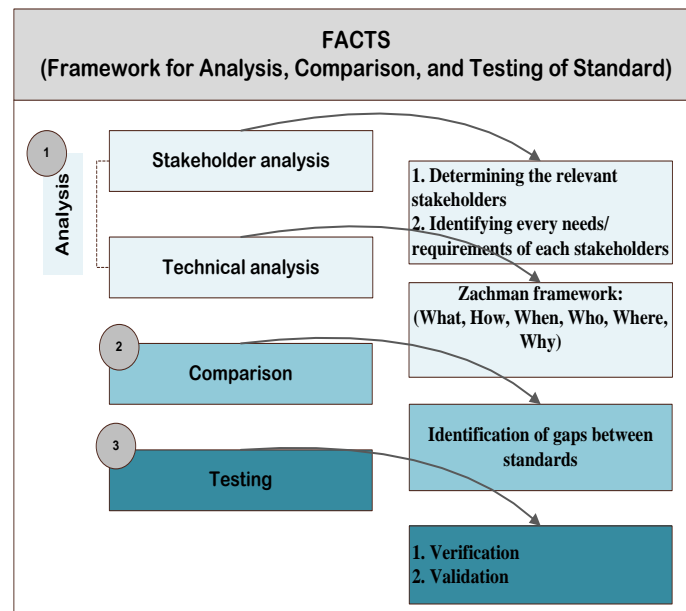

Figure 3. Stages of FACTS Approach

The Comparison is intended to do identification of gaps and overlaps between two or more analysis results [14]. The last stage of FACTS is testing. Testing is done by doing verification and validation. Verification is done through Focus Group Discussion (FGD) and interview by using questionnaire. Validation is done by testing the product (Lithium-ion rechargeable battery) in accordance with the tests which have been decided.

3. RESULTS AND DISCUSSION

3.1. Analysis

Stakeholder analysis was intended to define stakeholder requirements. In this research, the stakeholders which involved are government, battery tester laboratory, battery manufacture, the relevant experts, electric vehicle manufacture, and consumer. Table 1 shows the requirements of each stakeholder.

Technical analysis was intended to convert each stakeholder requirements into technical requirements. It help to define tests which needed for lithium-ion rechargeable battery in electric vehicle application. Technical analysis was done by using Zachman framework which used 6 basics questions (what, how, when, who, where, and why). Table 2 shows technical requirements of each stakeholder.

Table 1. Stakeholder Requirements

No	Stakeholder	Stakeholder Requirements
1	Government	high energy, small size, environmental friendliness, low emission, electric car can reach long distance (300 km), fast charging and safe
2	Battery testing laboratory	Low emission level, high safety, high power density, fast charging, high energy density, high safety, heat/ thermal resistance, good capacity, environmental friendliness
3	Battery manufacture	high energy density, high safety, heat/ thermal resistance, no over heated, long life cycle
4	The relevant experts	small size, light weight, fast charging, heat resistance, good capacity, long life cycle, save energy, good energy density
5	Electric vehicle manufacture	supporting to reach long distance (120 km/ hour), high power, supporting in fast speed, fast charging, water resistance (can be operated when the rain and flood are coming)
6	Consumer	environmental friendliness, supporting to reach long distance, low cost electric vehicle

Table 2. Technical requirements and comparison references standard

No	Stakeholder Requirements	Technical requirements	Comparison of referenced standard		
			ISO 12405-1	ISO12405-2	ISO 12405-3
1	High energy, good capacity : (government), high energy density : (Battery testing laboratory, Battery manufacture, The relevant experts)	Energy density (Wh/kg) measurement through a test is needed	sub-section 7.1 and 7.2 (energy and capacity test at different temperature and different discharge rate)	sub-section 7.1 and 7.2 (energy and capacity test at different temperature and different discharge rate)	
2	high power density: (Battery testing laboratory), high power: (Electric vehicle manufacture)	Power (Watt) measurement through a test is needed	sub-section 7.3 (power and internal resistant test)	sub-section 7.3 (power and internal resistant test)	
3	save energy: (The relevant experts)	Energy efficiency test is needed	sub-section 7.8 (energy efficiency test only for system)	sub-section 7.4 (energy efficiency test at fast charging only for system)	
4	long life cycle : (Battery manufacture, The relevant experts)	Cycle life test is needed	sub-section 7.9 (cycle life test only for system)	sub-section 7.7 (cycle life test only for system)	
5	high safety : (Battery testing laboratory, Battery manufacture)	Vibration test is needed	sub-section 8.3 (vibration test for high power applications)	sub-section 8.2 (vibration test for high energy applications)	sub-section 7.2 (mechanical test in form a vibration test)
		Mechanical shock test is needed	sub-section 8.4 (mechanical shock test for high power applications)	sub-section 8.4 (mechanical shock test for high energy applications)	sub-section 6.2 (mechanical test in form a mechanical shock)
		Electrical test and abuse test	sub-section 9.2 (short circuit protection)	sub-section 9.2 (short circuit protection)	sub-section 9.1 (short circuit protection)
			sub-section 9.3 (overcharge protection only for system)	sub-section 9.3 (overcharge protection only for system)	sub-section 10.1 (overcharge protection only for system)
	sub-section 9.4 (overdischarge protection only for system)	sub-section 9.4 (overdischarge protection only for system)	sub-section 10.2 (overdischarge protection only for system)		
7	fast charging : (Battery testing laboratory, Battery manufacture)	energy efficiency test at fast is needed		sub-section 7.4 (energy efficiency test at fast charging only for system)	

No	Stakeholder Requirements	Technical requirements	Comparison of referenced standard		
			ISO 12405-1	ISO12405-2	ISO 12405-3
8	thermal resistance : (Battery testing laboratory, Battery manufacture)	performance test at low and high temperature	sub-section 7.6 and 7.7 (cranking power at high and low temperature only for system)		
		reliability and climatic test which is related to thermal is needed	sub-section 8.1 (Dewing - temperature change test) sub-section 8.2 (thermal shock cycling)	sub-section 8.1 (Dewing - temperature change test) sub-section 8.2 (thermal shock cycling)	sub-section 7.1 (climatic test in form dewing test) sub-section 7.2 (climatic test in form thermal shock cycling test)

3.2. Comparison

Comparison was intended to know the gap between each standard which was used as reference. The standards which were used in this research is ISO 12405 series 1, 2 and 3. ISO 12405-1 provides specific test procedures for lithium-ion battery packs and systems specially developed for propulsion of road vehicles especially for high-power applications [40]. There are 4 main tests, namely general test, performance test, reliability test and abuse test. ISO 12405-2 provides specific test procedures for lithium-ion battery packs and systems specially developed for propulsion of road vehicles especially for high-energy applications [41]. ISO 12405-3 provides specific test procedures and related requirements to ensure an appropriate and acceptable level of safety of lithium-ion battery systems specifically developed for propulsion of road vehicles [42]. The other test is consisting of 5 steps, namely mechanical test, climatic tests, simulated vehicle accidents, electrical tests and system functionality tests. Subsequently, the comparison result between each test in the reference standards was associated to the result of technical analysis. Table 2 shows the result of technical analysis and comparison of standards.

3.3. Testing

There are two primary phases to test, first is verification and second is validation. Verification was done by Focus Group Discussion (FGD) with the stakeholders and interviewing the stakeholders using questionnaire. Verification was intended to know whether the standard had captured all the stakeholder requirements or not [16]. The verification through by FGD was done twice. The first is internal FGD which is done by drafters who consisted of battery testing laboratory, battery manufacture and the relevant experts. First FGD gave result that there were only 2 tests which were relevant to module battery lithium-ion, they were energy & capacity test and power and internal test which reference on ISO 12405-1 and ISO 12405-2. There were only 2 tests because the cost of module battery is expensive so the participants of FGD agreed that tests which have destructive character such as vibration, mechanical shock and short circuit were only to be done in cell level.

The second verification is external FGD, which was attended by all of the stakeholders in Indonesia. The FGD gave result that the national standard of lithium-ion battery module for electric vehicle still needed other tests which is intended to test the connection between cells in module form (assembled cell), ability of battery module in water environment, and the function of cooling system in battery module. Besides that, the stakeholders agreed that the cells which are used in module should be tested in accordance with cell standard. Besides doing FGD, the verification tests also have done by interviewing stakeholders by using questionnaire. Table 3 shows the questionnaire result.

Based on FGD and questionnaire, the new frameworks for module test have been done. The result is there are 8 parameters in standard. They related to battery cell performance, density energy of battery module, power of battery module, vibration, mechanical shock, water immersion, loss of thermal control/cooling, and short circuit. Figure 4 shows the detail of new framework for lithium-ion battery module in electric vehicle application.

The next steps after verification test is validation test. Validation test is going to be done by testing the module battery accordance with parameters in standard which have been agreed by all of the stakeholders.

Table 3. Recapitulation of questionnaire result

Framework of Module Battery Standard	Stakeholders					
	1	2	3	4	5	6
The standard regulates the current value of energy density (Wh/kg)	*	Yes	No	Yes	*	*
The standard regulates the current value of power (Watt)	*	Yes	No	Yes	*	*
Vibration test	*	Yes	Yes	Yes	*	*
Mechanical shock test	*	Yes	No	Yes	*	*
Thermal shock cycling test	*	Yes	No	No	*	*
Short circuit test	*	Yes	No	Yes	*	*

Note:

1. Government
 2. Battery testing laboratory
 3. Battery manufacture
 4. The relevant experts (R&D battery)
 5. Electric vehilce manufacture
 6. Consumer
- *still under discussion

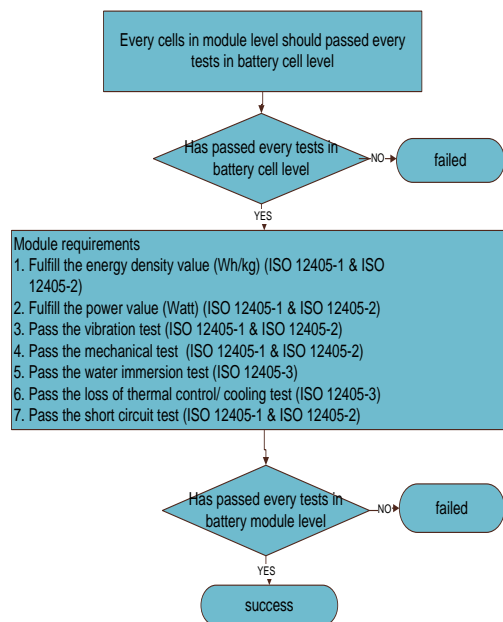

Figure 4. Framework of standard for lithium-ion battery module in electric vehicle application

4. CONCLUSION

This research used FACTS model to approach and make a framework for national standard of lithium-ion battery module in electric vehicle application. The content of standard shall consider the requirement of stakeholder. There are 6 stakeholders which are involved in standardization. Namely are government, battery testing laboratory, battery manufacture, the relevant experts, electric vehicle manufacture, and consumer. Based on the last FGD there are 8 parameters which must be fulfilled by lithium-ion battery module standardization.

ACKNOWLEDGEMENTS

This work was supported under Minister of Higher Education of Indonesia through University Sebelas Maret Research Grant.

REFERENCES

- [1] Q. Wang, P. Ping, X. Zhao, G. Chu, J. Sun, and C. Chen, "Thermal runaway caused fire and explosion of lithium ion battery," *Journal of Power Sources*, vol. 208, pp.210-224, February 2012., in press.
- [2] J. Chen, "Recent progress in advanced materials for lithium ion batteries," *Materials*, ISSN 1996-1944, 2013, in press.
- [3] I.A. Majid, R. F. Rahman, N.A. Setiawan, and A.I. Cahyadi, "*Electric vehicle battery dynamics modelling using support vector machine*," Joint International Conference on Rural Information & Communication Technology and Electric –Vehicle Technology, November 2013
- [4] X. Hu, F. Sun, and Y. Zou, "Estimation of state of charge of lithium-ion battery pack for electric vehicles using an adaptive luenberger observer," *Energies*, Vol. 3, ISSN. 1996-1073, September 2010, in press.
- [5] W.D. Indra, I.A. Majid, F.Sya'bani, R.F. Rahman, and A.I. Cahyadi, "*Battery modeling for lithium polymer battery management system*," Joint International Conference on Rural Information & Communication Technology and Electric –Vehicle Technology, November 2013.
- [6] A. Moshirvaziri, "Lithium-ion battery modeling for electric vehicles and regenerative cell testing platform," University of Toronto, Thesis, 2013.
- [7] C.H. Kim, M.Y. Kim, H.S. Park and G.W. Moon, "A modularized two-stage charge equalizer with cell selection switches for series-connected lithium-ion battery string in an HEV," *IEEE*, Vol. 27, No.8, August 2012, in press.
- [8] L. Lu, X. Han, J. Li, J. Hua, and M. Ouyang, "A review on the key issues for lithium-ion battery management in electric vehicles," *Journal of Power Sources*, vol. 226, pp. 271-288, 2013., in press.
- [9] F. Iskandar, A.S. Nisa, and M.M. Munir, "*Solvothermal synthesis of lithium iron phosphate from a high concentration precursor*," Joint International Conference on Rural Information & Communication Technology and Electric –Vehicle Technology, November 2013, in press.
- [10] H.J. Garche, B. Riegel, and C. Xiao, "Vehicle batteries in china and germany," German Chinese Sustainable Fuel Partnership (GCSFP), March 2009
- [11] BSN, "Pengantar standardisasi edisi kedua. Jakarta: badan standardisasi nasional", 2014.
- [12] BSN, "Tentang BSN," retrieved online: http://bsn.go.id/main/bsn/isi_bsn/43, June 2016.
- [13] IEC 62620, "Secondary cells and batteries containing alkaline or other non-acid electrolytes – Secondary lithium cells and batteries for use in industrial applications," 2014.
- [14] A. Tornow, M.P. Wollschlager, F. Dietrich, and K. Droder, "Detection and identification of assembly characteristics of lithium-ion battery modules using rgb-d imagery," *ELSEVIER, Procedia CIRP* 44, pp. 401-406, 2016.
- [15] S. Al-Hallaj, and J.R. Selman, "Thermal modeling of secondary lithium batteries for electric vehicle/hybrid electric vehicle applications," *Journal of Power Sources*, Vol. 110, pp. 341-348, 2002.
- [16] P. Witherell, S. Rachuri, A. Narayanan, and J.H. Lee, "FACTS: a framework for analysis, comparison, and testing of standards. National Institute of Standards and Technology, United States, 2013.
- [17] ISO, "Electrically propelled road vehicles- test specification for lithium-ion traction battery packs and system- high –power applications," Switzerland: ISO, 2011, in press.
- [18] ISO, "Electrically propelled road vehicles- test specification for lithium-ion traction battery packs and system- high –energy applications," Switzerland: ISO, 2012, in press.
- [19] ISO, "Electrically propelled road vehicles- test specification for lithium-ion traction battery packs and system- safety performance requirements," Switzerland: ISO, 2014, in press.

BIOGRAPHIES OF AUTHORS



Wahyudi Sutopo received his Master of Engineering and PhD in Industrial Engineering. He is currently a Associate Professor in Sebelas Maret University, Surakarta. His research is related to the battery and standardization of lithium battery and gets funded from ministry of higher education of Indonesia. Beside research his also active in professional consultancy in various of automotive industry in Indonesia and International.



Evizal Abdul Kadir received his Master of Engineering (M.Eng) and PhD in Wireless Communication from Faculty of Electrical Engineering Universiti Teknologi Malaysia, Malaysia in 2008 and 2014. He is currently a Senior Lecturer in Universitas Islam Riau (UIR), Indonesia. He have been worked in several companies that provide system solution in telecommunication and radio frequency identification (RFID), currently is continuing his research activity related to the wireless communication, computer networking and information system, Radio Frequency Identification (RFID) and Wireless Sensor Network (WSN). His research interest is in the field of antenna design, smart system, RFID, wireless sensor network and computer networking.