

Gauss-Seidel Method based Voltage Security Analysis of Distribution System

Gagari Deb¹, Kabir Chakraborty²

¹Department of Electrical Engineering, Tripura University (A Central University), India

²Department of Electrical Engineering, Tripura Institute of Technology, India

Article Info

Article history:

Received Mar 6, 2017

Revised Jul 27, 2017

Accepted Aug 11, 2017

Keyword:

Bus voltages

DSSI

Load multiplier factor

Phasor measurement unit

Voltage security

ABSTRACT

Complexity of modern power network and Large disturbance results voltage collapse. So, voltage security analysis is important in power system. Indicators are helpful in voltage stability analysis, as they give information about the state of the system. In this paper a new indicator namely Distribution System Stability Indicator (DSSI) has been formulated using the information of Phasor Measurement Unit (PMU). The proposed indicator (DSSI) is tested on standard IEEE 33 bus radial distribution system. The suggested indicator is also applicable to the equivalent two bus system of a multi-bus power system. The proposed indicator is calculated for different contingent conditions at different system load configurations. The result of DSSI is verified with the standard indicator (VSI) which proves applicability of the proposed indicator. The bus voltages of all the buses at base loading and at maximum loading are evaluated for base data and for tripping of most critical line.

Copyright © 2018 Institute of Advanced Engineering and Science.

All rights reserved.

Corresponding Author:

Gagari Deb,
Department of Electrical Engineering,
Tripura University(A Central University),
Suryamaninagar-799022, Tripura, West, India.
Email: gagarideb@tripurauniv.in

1. INTRODUCTION

Radial Distribution system has a large number of buses. So, it is not possible to maintain adequate bus voltage at each bus. This will increase the chance of voltage instability at the buses [1]. Increase in load demand will reduce the voltage at the receiving end which increases reactive power demand, if the power system is not able to supply the same there will be voltage collapse [2]. For proper operation of power system the voltage stability of the power system should be increased [3]. To improve power system stability and security, planning and operation of power system is essential [4]. Stability analysis may be of two forms- static and dynamic. In static analysis load flow based simulation is performed and in dynamic analysis time domain based analysis is performed [5]. With the implementation of phasor measurement unit (PMU) in power system for voltage security analysis the security level of power system has been increased. Online based methods and offline based methods both have been studied by the researchers for gaining information about voltage stability of power system using phasor measurement unit [6].

Different techniques have been used for voltage stability analysis. P-V curve and Q-V curve method [7-9] are the traditional methods of voltage stability analysis. Many indices such as SVSI [10], L-index [11], L_{mn} and VCPI [12], integrated voltage stability indicators [13] etc. can predict voltage instability in a power system. Other methods such as radial basis function and kohonen's self-organising feature map can also be found in literature for voltage stability analysis [14], [15]. In recent years a lot of work has been done in the area of voltage stability. Voltage stability analysis was done by the researchers using nodal analysis [16], modified differential evolution [17], coupled single port circuit [18], circuit theory

approach [19], catastrophe theory [20], chaotic particle swarm optimization algorithm [21], vector regression model [22] etc. Along with the other methods phasor measurement unit based schemes are also been used in power system to monitor voltage stability [23], [24]. PMU in substation gives voltage and current phasors information in a microsecond when the reading is taken. It capable the system for online monitoring. By using PMU data in the current literature accurate rating can be obtained.

This paper deals with a new voltage stability indicator which is used for monitoring voltage stability condition in base case as well as at maximum loading condition considering different line tripping condition. The developed distribution system stability indicator (DSSI) is tested on phasor measurement unit incorporated power system model of standard IEEE 33 bus radial distribution system. The result of DSSI indicator can accurately identify the critical conditions of line outage. The result is verified with the standard VSI indicator [25]. The change of bus voltages from base value to tripping of Line Number 23 is also shown for base load and maximum load.

2. RESEARCH METHOD

In this paper phasor measurement unit (PMU) incorporated voltage security analysis has been performed. PMU is allocated in every bus to give both magnitude and angle information of bus voltage and current.

Figure 1 shows the flowchart of the proposed method.

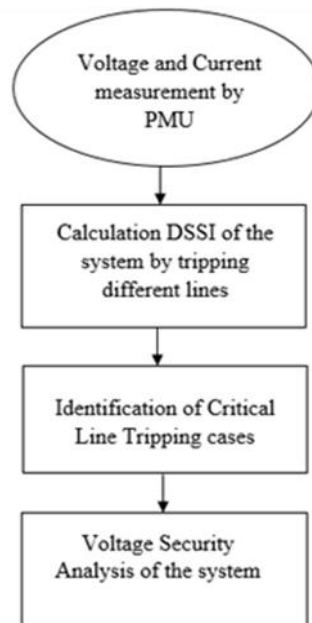

Figure 1. Flowchart of the proposed method

By using PMU at every bus of the concerned multi-bus system the voltage and current can be measured accurately at the same instant of time. These real time data from PMU are used in the proposed method to calculate the distribution system stability indicator (DSSI). Then this technique find the value of DSSI indicator for different conditions and from them identify the critical cases. From the results the voltage security analysis is performed.

3. DERIVATION OF THE PROPOSED INDEX FROM GAUSS-SEIDEL EQUATION

Figure 2 depicts a simplified two bus network where source is connected with bus number 1 (slack bus) and a load is connected to bus number 2 (load bus). To make the system observable in respect to voltage, phasor measurement unit is installed in both the buses. The current flow between bus number 1 and

bus number 2 is I. The load absorbs apparent power $S_2 = P_2 + j Q_2$ from the system. Two buses are connected together by impedance $Z_{eq} = R_{eq} + jX_{eq}$.

Assuming slack bus voltage equal to unity,

$$R_{eq} = \frac{P_{Gen} - P_{Load}}{P_{Gen}^2 + Q_{Gen}^2}, X_{eq} = \frac{Q_{Gen} - Q_{Load}}{P_{Gen}^2 + Q_{Gen}^2}$$

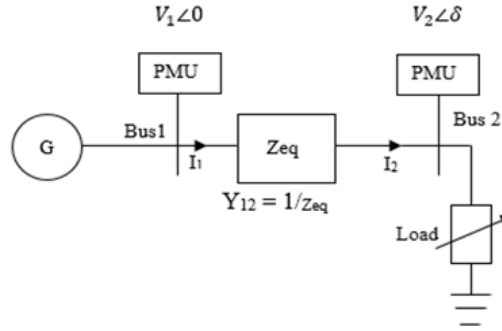

Figure 2. PMU incorporated simplified two bus network

The voltage at the receiving end bus that is at Bus number 2 is given as

$$V_2 = V_1 - \frac{Z_{eq}(P_{Gen} - jQ_{Gen})}{V_1} \quad (1)$$

The Gauss-Seidel load flow Equation for the two bus system can be written as

$$V_2 = \frac{1}{Y_{22}} \left[\frac{P_2 - jQ_2}{V_2^*} - Y_{12}V_1 \right] \quad (2)$$

Where, V_1 is the voltage at bus number 1, V_2 is the voltage at Bus number 2 and Y_{22} is the admittance of Bus number 2.

Equation (2) can be written as

$$\frac{P_2 - jQ_2}{V_2^*} - Y_{12}V_1 = V_2 Y_{22} = I_2 \quad (3)$$

$$\text{But, } I_1 = I_2 = I \quad (4)$$

From the two bus system of Figure 2 current I, can be written as,

$$I = \frac{V_1 \angle 0 - V_2 \angle \delta}{Z_{eq}} \quad (5)$$

Equating Equation (3) and Equation (5) it can be written that,

$$\begin{aligned} \frac{V_1 \angle 0 - V_2 \angle \delta}{Z_{eq}} &= \frac{P_2 - jQ_2}{V_2^*} - Y_{12}V_1 \\ \Rightarrow \frac{V_1 \angle 0 - V_2 \angle \delta}{Z_{eq}} + Y_{12}V_1 &= \frac{P_2 - jQ_2}{V_2^*} \\ \Rightarrow \frac{V_1 \angle 0 - V_2 \angle \delta}{Z_{eq}} + Y_{12}V_1 &= \frac{P_2 - jQ_2}{V_2 \angle -\delta} \\ \Rightarrow \frac{V_1 \angle 0 - V_2 \angle \delta + Y_{12}V_1 Z_{eq}}{Z_{eq}} &= \frac{P_2 - jQ_2}{V_2 \angle -\delta} \\ \Rightarrow V_1 V_2 \angle -\delta - V_2^2 + Z_{eq} Y_{12} V_1 V_2 \angle -\delta &= Z_{eq} P_2 - j Q_2 Z_{eq} \end{aligned} \quad (6)$$

Taking real part from Equation (6) it can be written as

$$\begin{aligned}
V_1 V_2 \cos \delta - V_2^2 + Y_{12} V_1 V_2 Z_{eq} \cos \delta &= Z_{eq} P_2 \\
\Rightarrow Z_{eq} P_2 - Y_{12} V_1 V_2 Z_{eq} \cos \delta &= V_1 V_2 \cos \delta - V_2^2 \\
\therefore Z_{eq} &= \frac{V_1 V_2 \cos \delta - V_2^2}{P_2 - Y_{12} V_1 V_2 \cos \delta} \quad (7)
\end{aligned}$$

Taking derivative of both sides of Equation (7) with respect to V_2 it can be written that,

$$\frac{d Z_{eq}}{d V_2} = \frac{(V_1 \cos \delta - 2V_2)(P_2 - Y_{12} V_1 V_2 \cos \delta) - (V_1 V_2 \cos \delta - V_2^2)(0 - Y_{12} V_1 \cos \delta)}{(P_2 - Y_{12} V_1 V_2 \cos \delta)^2} \quad (8)$$

After simplification Equation (8) can be written as,

$$\frac{d Z_{eq}}{d V_2} = \frac{Y_{12} V_1 V_2^2 \cos \delta - 2P_2 V_2 + P_2 V_1 \cos \delta}{(P_2 - Y_{12} V_1 V_2 \cos \delta)^2} \quad (9)$$

At critical point of voltage stability,

$$\frac{d Z_{eq}}{d V_2} = 0$$

So, Equation (9) it can be written as,

$$(Y_{12} V_1 \cos \delta) V_2^2 - (2P_2) V_2 + P_2 V_1 \cos \delta = 0$$

So, critical voltage at the receiving end of the equivalent two bus network is written as,

$$\therefore V_{2cri} = \frac{[P_2 - (P_2^2 - Y_{12} V_1^2 P_2 \cos^2 \delta)^{0.5}]}{Y_{12} V_1 \cos \delta} \quad (10)$$

Distribution system stability indicator (DSSI) can be formulated by the difference between the receiving end voltage of the equivalent two bus distribution system at base case and critical voltage at the receiving end of the equivalent two bus distribution system and can be written as,

$$DSSI = V_2 - V_{2cri}$$

Where, V_2 is the receiving end voltage of the two bus equivalent system and V_{2cri} is the critical voltage at the receiving end of the same system. So, at the critical point of voltage stability the difference between these two will be zero. The value of the proposed indicator will provide information about the voltage stability of the system. The higher value of DSSI indicator means the system is less secure in terms of voltage stability and lower value of DSSI indicator means more secure is the system in terms of voltage stability.

4. SIMULATION AND RESULTS

The program is simulated in MATLAB software and the developed indicator (DSSI) is implemented in standard IEEE 33 bus radial distribution system. The system is consist of active power load of 3715 kW and reactive power load of 2300 kVA. The whole system is reduced into two bus equivalent network. The result of DSSI indicator is compared with standard VSI indicator. The simulation results are described in the following sections.

4.1. Identification and Verification of Critical Contingency Cases

Contingencies are the harmful situations on power system that may occur during steady state condition of power system. The contingency condition may be outage of generators or tripping the line of a power system. To check the accuracy of the proposed indicator, DSSI is calculated for different contingent conditions of the said IEEE 33 bus radial distribution system. The results are verified by the standard VSI indicator.

Table 1 shows the results of the test.

Table 1. Contingency test results at base loading condition

System Configuration number	System Configuration	DSSI	VSI
1	Base case	0.9397	0.7332
2	Line 17 tripped	0.9398	0.7333
3	Line 19 tripped	0.9399	0.7342
4	Line 24 tripped	0.9401	0.7348
5	Line 30 tripped	0.9403	0.7357
6	Line 29 tripped	0.9409	0.7381
7	Line 23 tripped	0.9412	0.7395

Figure 3 shows the graph of DSSI indicator and VSI indicator for base case and various contingency conditions at base loading depicted in Table 1.

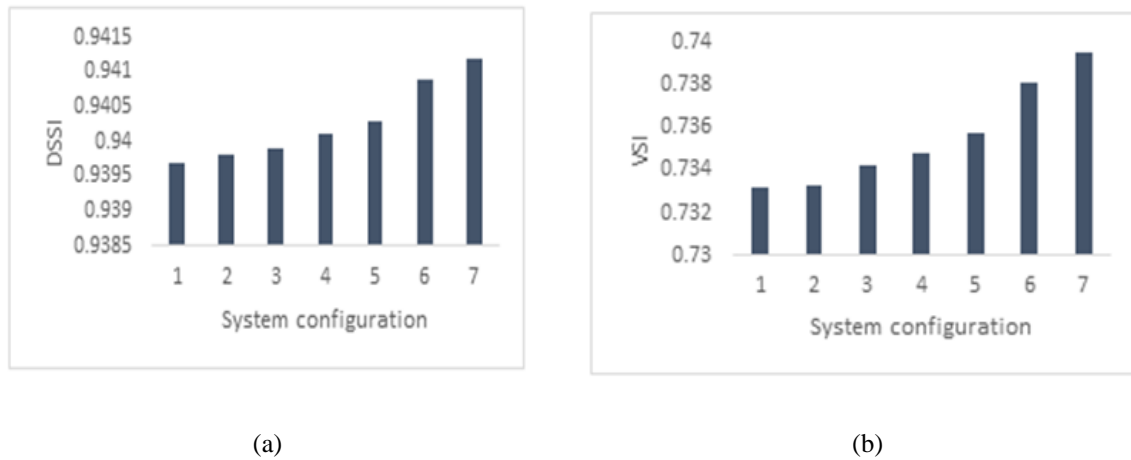

Figure 3. Plot of (a) DSSI and (b) VSI indicator for different configurations at base loading

Table 1 and Figure 3 clearly show that most severe contingency is system configuration 7 i.e. tripping of line number 23 because the value of the DSSI indicator is highest in this case. Proposed indicator, DSSI gives accurate result which is verified by the VSI indicator.

After performing contingency test at base load the loads of all the buses have increased successively with an increment of 5% until the load flow program fails to give solution. Maximum loading at which load flow program runs is known as the critical loading of the system. At maximum loading condition contingency test is performed to evaluate the change in the DSSI indicator value of the concerned power system.

Table 2 shows the result of contingency test at maximum loading condition.

Table 2. Contingency test results at maximum loading condition

System Configuration number	System Configuration	DSSI	VSI
1	Base data at maximum loading	0.9755	0.8877
2	Line 17 tripped	0.9756	0.8878
3	Line 19 tripped	0.9757	0.8881
4	Line 24 tripped	0.9758	0.8884
5	Line 30 tripped	0.9759	0.8889
6	Line 29 tripped	0.9760	0.8899
7	Line 23 tripped	0.9761	0.8906

Figure 4 shows the graph of DSSI indicator and VSI indicator for base case and various contingency conditions at maximum loading point.

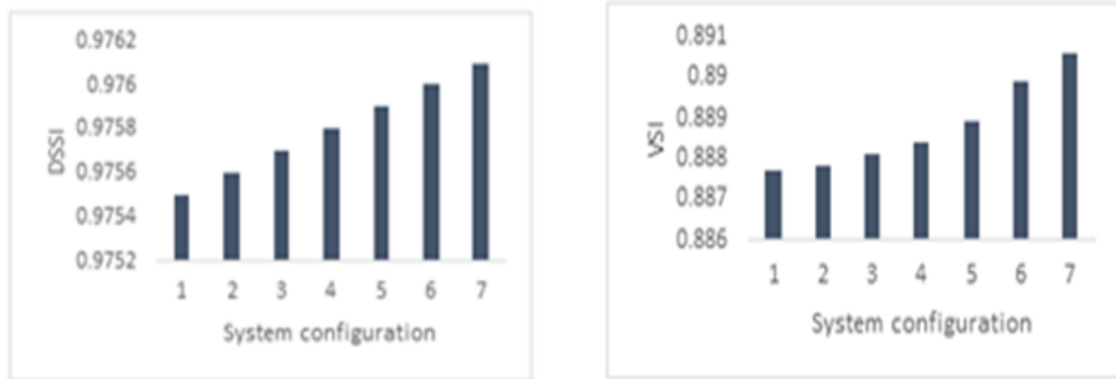

(a)

(b)

Figure 4. Plot of (a) DSSI and (b) VSI indicator for different configurations at maximum loading

Table 2 and Figure 4 proves that at maximum loading condition the worst situation is system configuration number 7 i.e. tripping of line number 23. The accuracy of the DSSI indicator is checked with VSI indicator.

At base loading, the effects of tripping of various lines affect the state of the system and accordingly the value of the indicator changes from base case. So, the change in the indicator values will give indication about tripping of line. With the change in load demand, the indicator value changes at every contingency. At the maximum loading condition the value of the indicator will be different from the indicator values at base loading for the same contingencies.

Figure 5 displays the change of DSSI indicator from base loading to maximum for different contingencies.

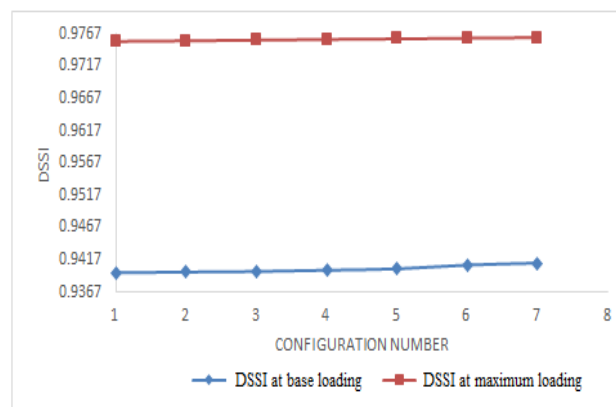

Figure 5. Comparison of DSSI value at base loading and at maximum loading

Figure 5 shows that at maximum loading condition the value will be higher than those obtained at base loading condition.

4.2. Effect of Contingency on Bus Voltages

Voltage magnitudes at different buses is also changes due to contingency. Figure 6 compares the bus voltages for base case and for tripping of Line number 23 at base loading.

Figure 6 shows that for base data and for tripping of line number 23 there is a small change in bus voltages.

At the point of maximum loading the system is more prone to voltage instability and the bus voltages may be less than the allowable limit. So, it is essential to check the bus voltages at this stage of power system. With the increase in loading the bus voltages will decrease.

Figure 7 shows the bus voltages at maximum loading for all the buses of the concerned distribution system for base data and for outage of line number 23.

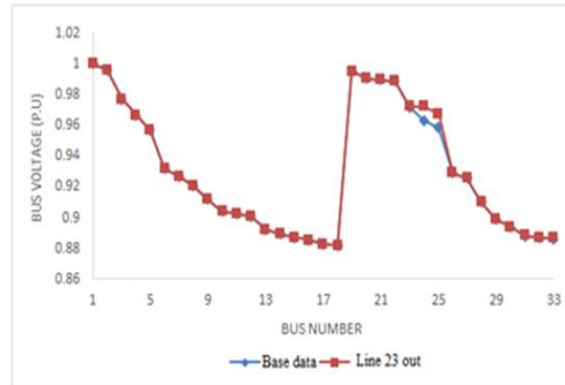

Figure 6. Comparison of original bus voltages and bus voltages for outage of line number 23 at base loading

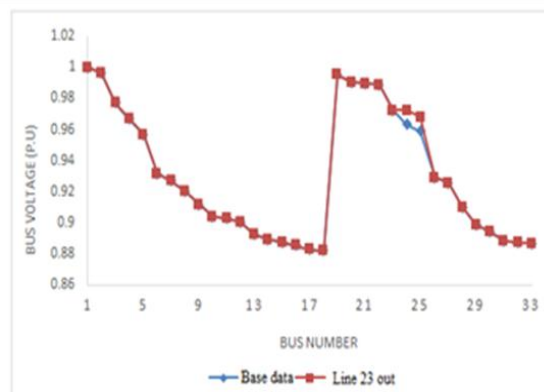

Figure 7. Comparison of actual bus voltages and bus voltages for tripping of line 23 at maximum loading

Figure 7 shows that the variation in bus voltages with actual data and for tripping of Line number 23 at maximum loading is very small.

5. CONCLUSION

By applying the proposed indicator the critical contingency cases of the system can be identified very easily which is also verified by the standard VSI indicator. At maximum loading the security state can be accessed by the values of DSSI indicator for various line tripping conditions. If the bus voltages are below the adequate value set for the system, control action can be taken to improve the bus voltages and voltage stability for the system can be improved. From the knowledge of the indicator the power system operator will be able to check the voltage stability limit. The DSSI value will also able the user to predict the contingency cases. So, it will be possible to provide protection to the power system.

REFERENCES

- [1] Suyanto, C. Rahmadhani, O. Penangsang and A. Soeprijanto, "Power Flow Development Based on the Modified Backward-Forward for Voltage Profile Improvement of Distribution System," *International Journal of Electrical and Computer Engineering*, vol. 6, No.5, pp. 2005-2014, 2016.

- [2] K. Mistry and R. Roy, "Enhancement of voltage stability Index of Distribution System by Network Reconfiguration Including Static Load Model and Daily Load Curve," in *2011 IEEE PES Innovative Smart Grid Technologies-India*, 2011.
- [3] P. Pavithren, R.R. Raman, P. Nair and K.Nithiyanan, "Voltage Stability Analysis and Stability Improvement of Power System," *International Journal of Electrical and Computer Engineering*, vol. 5, No.2, pp. 189-197, 2015.
- [4] T. Zabaoui, L.A. Dessaint and I. Kamwa, "Preventive Control Approach for Voltage Stability Improvement Using Voltage Stability Constrained Optimal Power Flow Based on Static Line Voltage Stability Indices," *IET Generation, Transmission & Distribution*, vol. 8, Iss.5, pp. 924-934, 2014.
- [5] H. Khoshkhoo and S.M. Shahrtash, "Fast Online Dynamic Voltage Instability Prediction and Voltage Stability Classification," *IET Generation, Transmission & Distribution*, vol. 8, Iss.5, pp. 957-965, 2014.
- [6] I.R. Pordanjani, Y. Wang and W. Xu, "Identification of Critical Components for Voltage Stability Assessment Using Channel Components Transform," *IEEE Transactions on Smart Grid*, vol. 4, No.2, pp. 1122-1132, June 2013.
- [7] M.A. Akher, "Voltage Stability Analysis of Unbalanced Distribution Systems using Backward/Forward Sweep Load Flow Analysis Method with Secant Predictor," *IET Generation, Transmission & Distribution*, vol. 7, Iss.3, pp. 309-317, 2013.
- [8] K. Kawabe and K. Tanaka, "Analytical Method for Short-Term Voltage Stability Using the Stability Boundary in the P-V Plane," *IEEE Transactions on Power Systems*, vol. 29, No.6, pp. 3041-3047, 2014.
- [9] S. Konar, D. Chatterjee and S. Patra, "V-Q Sensitivity-based Index for Assessment of Dynamic Voltage Stability of Power Systems," *IET Generation, Transmission & Distribution*, vol. 9, Iss.7, pp. 677-685, 2015.
- [10] S.P. Londono, L.F. Rodriguez and G. Olivar, "A Simplified Voltage Stability Index (SVSI)," *Electrical Power and Energy Systems*, vol. 63, pp. 806-813, 2014.
- [11] T.A.V. Ram and K.M. Haneesh, "Voltage Stability Analysis Using L-index Under Various Transformer Tap Changer Settings," in 2016 International Conference on Circuit, Power and Computing Technologies (ICCPCT), March 2016.
- [12] M. Cupelli, C.D. Cardet and A. Monti, "Voltage Stability Indices Comparison on the IEEE-39 Bus System using RTDS," in 2012 IEEE International Conference on Power System Technology (POWERCON), pp. 1-6, November, 2012.
- [13] K. Chakraborty, A. Chakrabarti and A. De, "Integrated Voltage Stability Indicator Based Assessment of Voltage Stability in a Power System and Application of ANN," *Iranian Journal of Electrical and Computer Engineering*, vol. 10, No. 2, pp. 85-92, 2011.
- [14] A. De, K. Chakraborty and A. Chakrabarti, "Classification Power System Voltage Stability Conditions using Kohonen's Self organising Feature Map and Learning Vector Quantisation," *European Transactions on Electrical Power*, vol. 22, pp. 412-420, 2012.
- [15] K. Chakraborty, A. De and A. Chakrabarti, "Assessment of Voltage Security in a Multi-bus Power System Using Artificial Neural Network and Voltage Stability Indicators," *Journal of Electrical Systems*, vol. 6-4, pp. 517-529, 2010.
- [16] D.H.A. Lee, "Voltage Stability Assessment Using Equivalent Nodal Analysis," *IEEE Transactions on Power Systems*, vol. 31, No.1, pp. 454-463, January 2016.
- [17] C. M. Selvi and K.Gnanambal, "Power System Voltage Stability Analysis using Modified Differential Evolution," in International Conference on Computer, Communication and Electrical Technology- ICCET 2011, March, 2011.
- [18] Y. Wang, I.R. Pordanjani, W. Li, W. Xu, T. Chen, E. Vaahedi and G. Gurney, "Voltage Stability Monitoring Based on the Concept of Coupled Single-Port Circuit," *IEEE Transactions on Power Systems*, vol. 26, No.4, pp. 2154-2163, November 2011.
- [19] S. Chitra and N. Devarajan, "Circuit Theory Approach for Voltage Stability Assessment of Reconfigured Power Network," *IET Circuits, Devices and Systems*, vol. 8, Iss. 6, pp. 435-441, 2014.
- [20] G.A. Mahmoud, "Voltage Stability Analysis of Radial Distribution Networks using Catastrophe Theory," *IET Generation, Transmission & Distribution*, vol. 6, Iss.7, pp. 612-618, 2012.
- [21] L. Kuru, A. Ozturk, E. Kuru and O. Kandara, "Determination of Voltage Stability Boundary Values in Electrical Power Systems by using the Chaotic Particle Swarm Optimization Algorithm," *Electrical Power and Energy systems*, vol. 64, pp. 873-879, 2015.
- [22] M.V. Suganyadevi and C.K. Babulal, "Support Vector Regression Model for the Prediction of Loadability Margin of a Power System," *Applied Soft Computing*, vol. 24, pp. 304-315, 2014.
- [23] C. Zheng, V. Malbasa and M. Kezunovic, "Regression Tree for Stability Margin Prediction using Synchrophasor Measurements," *IEEE Transactions on Power Systems*, vol. 28, No.2, pp. 1978-1987, May 2013.
- [24] J.H. Liu and C.C. Chu, "Wide-Area Measurement –Based Voltage Stability Indicators by Modified Coupled Single-Port Models," *IEEE Transactions on Power Systems*, vol. 29, No.2, pp. 756-764, March 2014.
- [25] S.M.S. Hussain and N. Visali, "Identification of Weak Buses using Voltage Stability Indicator and its Voltage Profile Improvement by using DSTATCOM in Radial Distribution Systems," *IOSR Journal of Electrical and Electronics Engineering (IOSRJEEE)*, vol. 2, Issue 4, pp. 17-23

BIOGRAPHIES OF AUTHORS

Gagari Deb was born in Tripura on February 24, 1982. She has completed her B.E in Electrical Engineering from Tripura Engineering College (now NIT, Agartala) in 2004. She has completed her M.Tech in Electrical Engineering from Tripura University (A Central University) in the year 2008. She is presently working as an Assistant Professor in Department of Electrical Engineering in Tripura University (A Central University). Her research area is Power System. She is currently pursuing Ph. D degree from National Institute of Technology, Agartala, Tripura, India.



Kabir Chakraborty was born in Dharmanagar, Tripura, India, on August 5, 1978. He is Assistant Professor in the department of Electrical Engineering at Tripura Institute of Technology, Narsingarh, Tripura, India. He holds a B.Sc. Physics (Hons.) from Assam University, and B.Tech and M.Tech in Electrical Engineering from the University of Calcutta. He completed his PhD in 2013 from Indian Institute of Engineering Science and Technology (IEST), Shibpur, (Formerly Bengal Engineering and Science University, Shibpur,) West Bengal, India. He has 12 years of teaching and 6 years of research experience. He has published several papers in international and national journals and conference proceedings and a book.